



FINAL DRAFT International Standard

ISO/FDIS 18847

Solid biofuels — Determination of particle density of pellets and briquettes

*Biocombustibles solides — Détermination de la masse volumique
unitaire des granulés et des briquettes*

ISO/TC 238

Secretariat: **SIS**

Voting begins on:
2024-01-23

Voting terminates on:
2024-03-19

iTech Standards
(<https://standards.iteh.ai>)
Document Preview

[ISO/FDIS 18847](#)

<https://standards.iteh.ai/catalog/standards/iso/52f121c4-e77d-499c-8bfa-8469d0fa88f2/iso-fdis-18847>

ISO/CEN PARALLEL PROCESSING

RECIPIENTS OF THIS DRAFT ARE INVITED TO SUBMIT, WITH THEIR COMMENTS, NOTIFICATION OF ANY RELEVANT PATENT RIGHTS OF WHICH THEY ARE AWARE AND TO PROVIDE SUPPORTING DOCUMENTATION.

IN ADDITION TO THEIR EVALUATION AS BEING ACCEPTABLE FOR INDUSTRIAL, TECHNOLOGICAL, COMMERCIAL AND USER PURPOSES, DRAFT INTERNATIONAL STANDARDS MAY ON OCCASION HAVE TO BE CONSIDERED IN THE LIGHT OF THEIR POTENTIAL TO BECOME STANDARDS TO WHICH REFERENCE MAY BE MADE IN NATIONAL REGULATIONS.

iTeh Standards
(<https://standards.iteh.ai>)
Document Preview

ISO/FDIS 18847

<https://standards.iteh.ai/catalog/standards/iso/52f121c4-e77d-499c-8bfa-8469d0fa88f2/iso-fdis-18847>



COPYRIGHT PROTECTED DOCUMENT

© ISO 2024

All rights reserved. Unless otherwise specified, or required in the context of its implementation, no part of this publication may be reproduced or utilized otherwise in any form or by any means, electronic or mechanical, including photocopying, or posting on the internet or an intranet, without prior written permission. Permission can be requested from either ISO at the address below or ISO's member body in the country of the requester.

ISO copyright office
CP 401 • Ch. de Blandonnet 8
CH-1214 Vernier, Geneva
Phone: +41 22 749 01 11
Email: copyright@iso.org
Website: www.iso.org

Published in Switzerland

Contents

	Page
Foreword	iv
Introduction	v
1 Scope	1
2 Normative references	1
3 Terms and definitions	1
4 Principle	1
5 Reagents	1
6 Apparatus	2
6.1 General apparatus requirements.....	2
6.2 Apparatus for pellet testing.....	2
6.3 Apparatus for briquette testing.....	3
7 Sample preparation	4
7.1 General apparatus requirements.....	4
8 Procedures	5
8.1 Procedure for pellets.....	5
8.2 Procedure for briquettes.....	6
9 Calculation	6
10 Performance characteristics	7
10.1 General.....	7
10.2 Repeatability.....	7
10.3 Reproducibility.....	7
11 Test report	7
Annex A (informative) Stereometric volume estimation	8
Annex B (informative) Estimation of the particle density of pellets by liquid displacement	12
Bibliography	14

Foreword

ISO (the International Organization for Standardization) is a worldwide federation of national standards bodies (ISO member bodies). The work of preparing International Standards is normally carried out through ISO technical committees. Each member body interested in a subject for which a technical committee has been established has the right to be represented on that committee. International organizations, governmental and non-governmental, in liaison with ISO, also take part in the work. ISO collaborates closely with the International Electrotechnical Commission (IEC) on all matters of electrotechnical standardization.

The procedures used to develop this document and those intended for its further maintenance are described in the ISO/IEC Directives, Part 1. In particular, the different approval criteria needed for the different types of ISO document should be noted. This document was drafted in accordance with the editorial rules of the ISO/IEC Directives, Part 2 (see www.iso.org/directives).

ISO draws attention to the possibility that the implementation of this document may involve the use of (a) patent(s). ISO takes no position concerning the evidence, validity or applicability of any claimed patent rights in respect thereof. As of the date of publication of this document, ISO had not received notice of (a) patent(s) which may be required to implement this document. However, implementers are cautioned that this may not represent the latest information, which may be obtained from the patent database available at www.iso.org/patents. ISO shall not be held responsible for identifying any or all such patent rights.

Any trade name used in this document is information given for the convenience of users and does not constitute an endorsement.

For an explanation of the voluntary nature of standards, the meaning of ISO specific terms and expressions related to conformity assessment, as well as information about ISO's adherence to the World Trade Organization (WTO) principles in the Technical Barriers to Trade (TBT), see www.iso.org/iso/foreword.html.

This document was prepared by Technical Committee ISO/TC 238, *Solid biofuels*, in collaboration with the European Committee for Standardization (CEN) Technical Committee CEN/TC 335, *Solid biofuels*, in accordance with the Agreement on technical cooperation between ISO and CEN (Vienna Agreement).

This second edition cancels and replaces the first edition (ISO 18847:2016), which has been technically revised.

The main changes are as follows:

- editorial changes made;
- ISO 21945 inserted as a normative reference;
- method for the determination of particle density is specified in more detail;
- informative [Annex B](#) on a liquid displacement method to estimate the particle density of pellets added.

Any feedback or questions on this document should be directed to the user's national standards body. A complete listing of these bodies can be found at www.iso.org/members.html.

Introduction

Particle density is a fuel parameter of pellets and briquettes which is often considered when describing the degree of compaction of the raw material used. Particle density can be highly specific for the respective type or species of biomass and thus, it also characterizes the material's general ability to be compacted. High particle density is often associated with high resistance to abrasion or low susceptibility towards fracturing during handling and storage. A high particle density also generally leads to reduced storage volume demands and to a lower filling level in a combustion chamber at constant fuel mass flow. Particle density can also affect the heat transfer rate within the fuel and thus, it can have an impact on fuel ignition and on the dynamics of gasification.

Apart from the buoyancy method which is described in this document as a reference method, larger particles (briquettes) are sometimes easier tested by simple stereometric means. For internal laboratory practices, such a procedure is also presented in [Annex A](#). For small particles (pellets), this procedure is not recommended.

For pellets, a simplified method using the displacement of a liquid by the pellets is available, which can be used as an on-site method, and is described in [Annex B](#).

Pellets disintegrate in water relatively fast, but with the buoyancy method the particle density is sufficiently stable for about 30 s (see [3]). To improve reproducibility, the reading of the results is fixed at 5 s. This also ensures synchronization with the results of the estimation method by liquid displacement.

For the determination of particle density, several other methods are available. Normally the results show only minor deviations.

iTeh Standards
(<https://standards.itih.ai>)
Document Preview

[ISO/FDIS 18847](#)

<https://standards.itih.ai/catalog/standards/iso/52f121c4-e77d-499c-8bfa-8469d0fa88f2/iso-fdis-18847>

Solid biofuels — Determination of particle density of pellets and briquettes

1 Scope

This document specifies a method for determining the particle density of compressed fuels such as pellets or briquettes. Particle density is not an absolute value and conditions for its determination have to be standardized to enable comparative determinations to be made.

2 Normative references

The following documents are referred to in the text in such a way that some or all of their content constitutes requirements of this document. For dated references, only the edition cited applies. For undated references, the latest edition of the referenced document (including any amendments) applies.

ISO 14780, *Solid biofuels — Sample preparation*

ISO 16559, *Solid biofuels — Vocabulary*

ISO 18135, *Solid Biofuels — Sampling*

ISO 21945, *Solid biofuels — Simplified sampling method for small scale applications*

3 Terms and definitions

For the purposes of this document, the terms and definitions given in ISO 16559 apply.

ISO and IEC maintain terminology databases for use in standardization at the following addresses:

- ISO Online browsing platform: available at <https://www.iso.org/obp>
- IEC Electropedia: available at <https://www.electropedia.org/>

4 Principle

Both mass and volume of an individual particle or a group of particles are determined. The volume is measured by determining the buoyancy in a liquid. This procedure follows the physical principle that the buoyancy is equal to the mass of the displaced volume of a liquid. The apparent loss in weight between a measurement in air and a subsequent measurement in liquid marks its buoyancy. The volume of the test portion body is calculated via the density of the applied liquid.

NOTE 1 The particle density of briquettes can alternatively be estimated by stereometric means (see [Annex A](#)).

NOTE 2 As an on-site method the particle density of pellets can be estimated by a displacement method (see [Annex B](#)).

5 Reagents

5.1 Water, with a conductivity < 1 000 $\mu\text{S}/\text{cm}$ (e.g. typical drinking water quality) in a temperature range of 10 °C to 30 °C.

5.2 Detergent. A non-ionic surfactant detergent named O-[4-(1,1,3,3-Tetramethylbutyl)-phenyl]-deca(oxyethylen), Octylphenoldecaethylen-glycolether, Polyethylenglycol-mono-[p-(1,1,3,3-tetramethylbutyl)-phenyl]-ether. Alternatively, a non-ionic surfactant with similar properties may be used, e. g. Ethylene oxide-propylene oxide copolymer mono(2-ethylhexyl) ether.

Using an alternative detergent, the density of the liquid used for the determination (water with 1, 5 g/l detergent) shall be determined to the nearest 0,001 g/l and used for calculations instead of the value given in [clause 9](#).

NOTE The exclusive use of a specific detergent with given characteristics allows to apply a fixed value for the density of the liquid (mixture with water) and ensures constant properties as wetting agent. As an example, the detergent available under the name Triton® X-100¹⁾ can be used. The density at +20 °C is 1,07 g/ml. According to health and/or environmental regulations the use of an alternative detergent can be necessary.

5.3 Paraffin, with a melting point of 52 °C to 54 °C.

6 Apparatus

6.1 General apparatus requirements

A thermometer capable of reading to the nearest 1 °C.

6.2 Apparatus for pellet testing

6.2.1 Balance, shall be capable of reading to the nearest 0,001 g.

6.2.2 Glass beaker, a transparent glass beaker with a filling volume of about 200 ml.

6.2.3 Density determination rig. The density determination rig consists of a bridge and a submergence rig.

The bridge overstretches the weighing plate of the balance in order to prevent the balance from being loaded. The bridge is capable of carrying the *glass beaker* (6.2.2).

The submergence rig consists of a supporting frame and a submergence unit (submergence bracket with a submergence dish), which is hung into the *glass beaker* (6.2.2) to weigh the pellets in liquid (see [Figure 1](#)). The submergence dish shall be able to accommodate at least four pellets at once.

The submergence rig is directly placed on the balance plate.

Through the submergence bracket the submergence depth is always kept constant. The bottom of the submergence dish is perforated by openings, which are smaller in diameter than the diameter of the pellets. The perforation allows the liquid to fill the dish from underneath when it is submerged. If material of low density is tested (below 1,0 g/cm³) a modified suspension having an inverted submergence dish is required; this is to force the pellets underneath the liquid surface and prevent them from floating on top of the liquid.

For the determination of the mass in air, a weighing dish shall be fixed on top of the suspension rig ([Figure 1](#)).

1) Triton® X-100 is the trademark of a product supplied by Dow. This information is given for the convenience of users of this document and does not constitute an endorsement by ISO of the product named. Equivalent products may be used if they can be shown to lead to the same results.

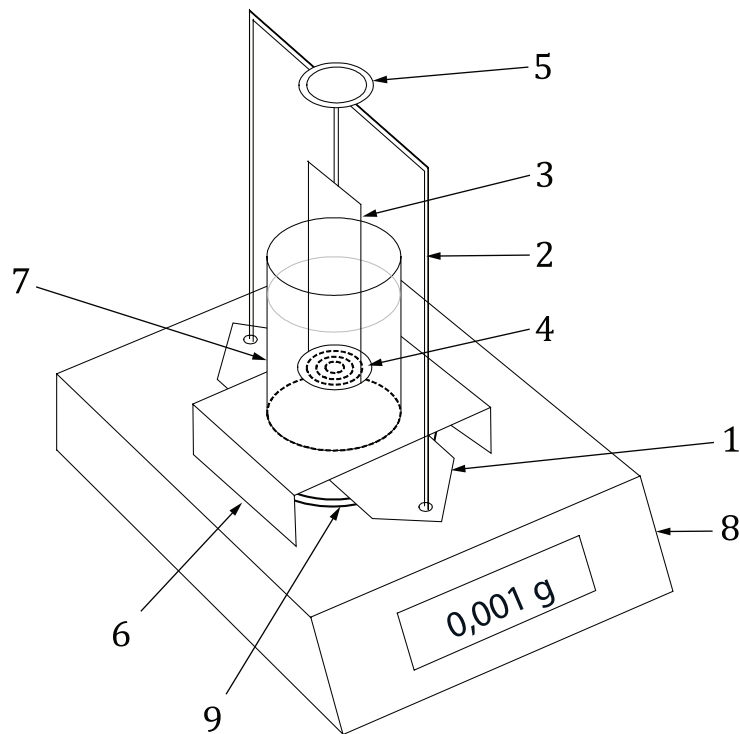

Key

- | | | | |
|---|---------------------|---|---------------------------|
| 1 | submergence rig | 6 | bridge |
| 2 | supporting frame | 7 | glass beaker |
| 3 | submergence bracket | 8 | balance |
| 4 | submergence dish | 9 | weighing plate of balance |
| 5 | weighing dish | | |

NOTE Submergence dish for pellets with density below 1,0 g/m³ is not shown in this figure.

Figure 1 — Density determination rig on a balance (method for pellets)

6.3 Apparatus for briquette testing

6.3.1 General

[Figure 2](#) shows the set up for measuring density of large particles (briquettes)

6.3.2 Balance, shall be capable of reading to the nearest 0,01 g.

If briquettes of more than 500 g each are tested, the balance shall be capable of reading to the nearest 0,1 g.

The balance shall have a connecting point for hanging a weight to its load cell.

6.3.3 Transparent container for liquid, having a sufficient filling volume to accommodate the liquid and the submerged briquette.

A sufficient filling volume is usually achieved when the container's cross section is about eight times larger than the cross section of the briquette. In this case, any effects by level changes of the liquid caused by submersion of the briquette are negligible. Such error would be due to a larger part of the holding steel string ([6.3.4](#)) being submerged.

6.3.4 Non-absorbent thin steel string, which can be hung to the connecting point of the balance.

The end of the string is equipped with a hook or a ring, which allows an easy appending of the briquette.

6.3.5 Tripod, on which a balance can be placed. The tripod should have a plate with an opening which allows the string to pass through unhindered to the balance (Figure 2) while hanging.

6.3.6 Steel loop or any other steel support device, to which the briquette can be fixed while freely hanging and which allows to be fixed to the lower connecting point (Figure 2) of the steel string.

6.3.7 Removable weight, required if material of low density is tested (below 1,0 g/cm³), which is positioned onto the briquette in a way which prevents the briquette from floating on top of the liquid.

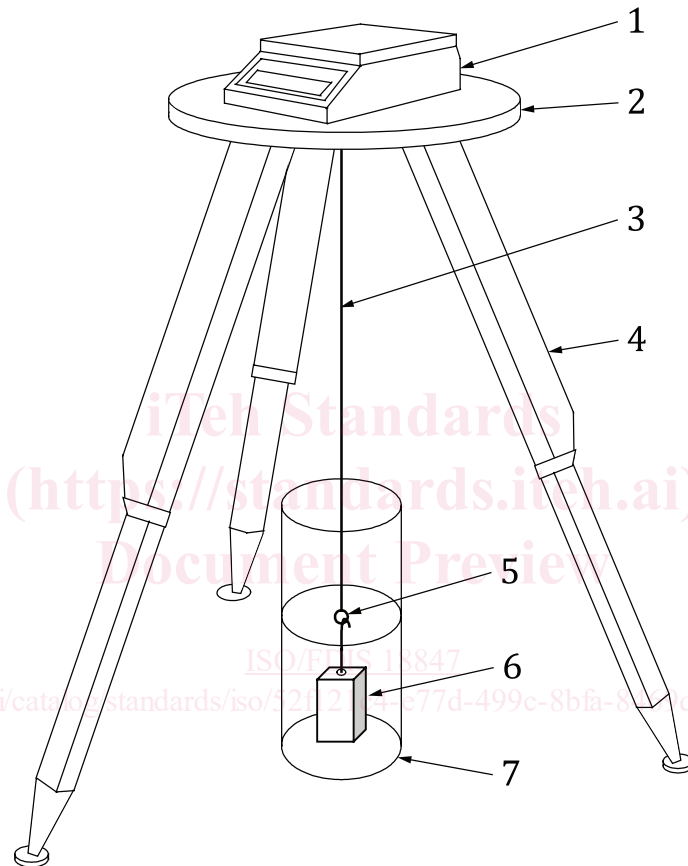

Key

- | | | | |
|---|-----------------------------|---|-------------------------|
| 1 | balance | 5 | connection ring or hook |
| 2 | carrying plate with opening | 6 | test piece (briquette) |
| 3 | steel string | 7 | transparent container |
| 4 | tripod | | |

Figure 2 — Buoyancy determination rig using a hanging load to a balance (method for briquettes)

7 Sample preparation

7.1 General apparatus requirements

A laboratory sample shall be obtained in accordance with ISO 18135 or ISO 21945 and a test sample shall be prepared in accordance to ISO 14780.