INTERNATIONAL STANDARD



3332

INTERNATIONAL ORGANIZATION FOR STANDARDIZATION • МЕЖДУНАРОДНАЯ ОРГАНИЗАЦИЯ ПО СТАНДАРТИЗАЦИИ • ORGANISATION INTERNATIONALE DE NORMALISATION

Ammonium sulphate for industrial use – Determination of ammoniacal nitrogen content – Titrimetric method after distillation

Sulfate d'ammonium à usage industriel – Dosage de l'azote ammoniacal – Méthode titrimétrique après distillation

iteh STANDARD PREVIEW

First edition – 1975-07-15

(standards.iteh.ai)

[ISO 3332:1975](https://standards.iteh.ai/catalog/standards/sist/4149645F-d6a1-47e0-93cf-1841bece158/iso-3332-1975)

<https://standards.iteh.ai/catalog/standards/sist/4149645F-d6a1-47e0-93cf-1841bece158/iso-3332-1975>



UDC 661.522 : 546.171 : 543.24

Ref. No. ISO 3332-1975 (E)

Descriptors : ammonium sulphate, chemical analysis, determination of content, nitrogen, volumetric analysis.

FOREWORD

ISO (the International Organization for Standardization) is a worldwide federation of national standards institutes (ISO Member Bodies). The work of developing International Standards is carried out through ISO Technical Committees. Every Member Body interested in a subject for which a Technical Committee has been set up has the right to be represented on that Committee. International organizations, governmental and non-governmental, in liaison with ISO, also take part in the work.

Draft International Standards adopted by the Technical Committees are circulated to the Member Bodies for approval before their acceptance as International Standards by the ISO Council.

International Standard ISO 3332 was drawn up by Technical Committee ISO/TC 47, *Chemistry*, and circulated to the Member Bodies in March 1974.

It has been approved by the Member Bodies of the following countries :

Austria	Hungary	South Africa, Rep. of
Belgium	India	Spain
Bulgaria	Ireland	Switzerland
Chile	Israel	Thailand
Czechoslovakia	Italy	Turkey
Egypt, Arab Rep. of	Netherlands	United Kingdom
France	New Zealand	U.S.S.R.
Germany	Poland	Yugoslavia

No Member Body expressed disapproval of the document.

Ammonium sulphate for industrial use – Determination of ammoniacal nitrogen content – Titrimetric method after distillation

1 SCOPE AND FIELD OF APPLICATION

This International Standard specifies a titrimetric method, after distillation, for the determination of the ammoniacal nitrogen content of ammonium sulphate for industrial use.

2 PRINCIPLE

Distillation of the ammonia after displacement by an alkali solution; absorption in an excess of standard volumetric sulphuric acid solution and back-titration with standard volumetric sodium hydroxide solution in the presence of an indicator.

3 REAGENTS

During the analysis, use only reagents of recognized analytical reagent grade and only distilled water or water of equivalent purity.

3.1 Sodium hydroxide, 450 g/l solution.

3.2 Sulphuric acid, 0,5 N standard volumetric solution.

3.3 Sodium hydroxide, 0,5 N standard volumetric solution.

3.4 Mixed indicator, ethanolic solution.

Dissolve 0,1 g of methyl red in about 50 ml of 95 % (V/V) ethanol, add 0,05 g of methylene blue and, after dissolution, dilute to 100 ml with the same ethanol.

4 APPARATUS

Ordinary laboratory apparatus and

4.1 Distillation apparatus, with, preferably, spherical ground glass joints, or any apparatus that will ensure quantitative distillation and absorption.

The apparatus may, for example, be made up from the following items (see figure) :

4.1.1 Distillation flask (A), capacity 1 000 ml, with a female joint.

4.1.2 Splash head (B), with male joints and parallel inlet and outlet into which is fused a cylindrical dropping funnel (C), capacity 50 ml.

4.1.3 Liebig condenser (D), effective length about 400 mm, fitted with a female joint at the inlet and a male joint at the outlet.

4.1.4 Conical flask (E), capacity 500 ml, with a female joint, fitted with two side bulbs.

4.1.5 Spring clamps (F).

5 PROCEDURE¹⁾

5.1 Test portion

Weigh, to the nearest 0,001 g, about 10 g of the test sample.

5.2 Blank test

Carry out a blank test at the same time as the determination, following the same procedure and using the same quantities of all the reagents as used for the determination.

5.3 Determination

5.3.1 Preparation of the sample solution

Place the test portion (5.1) in a 500 ml one-mark volumetric flask, dissolve in water, dilute to the mark and mix.

5.3.2 Distillation

Place 50,0 ml of the sample solution (5.3.1) in the distillation flask (A). Add about 350 ml of water and a few anti-bumping granules.

Coat the joints of the apparatus with a silicone grease. Mount the splash head (B) on the flask (A), and connect it to the condenser (D).

Place 40,0 ml of the standard volumetric sulphuric acid solution (3.2), about 80 ml of water and a few drops of the mixed indicator solution (3.4) into the flask (E). Connect the flask (E) to the condenser (D), ensuring that all the joints of the apparatus are firm by means of the spring clamps (F).

1) The procedure is described in terms of the apparatus specified in 4.1 and will require modification if other apparatus is used.

Introduce 20 ml of the sodium hydroxide solution (3.1) into the flask (A) through the dropping funnel (C), taking care to leave at least a few millimetres of liquid above the tap.

Distil until the volume of liquid in the flask (E) has reached about 250 to 300 ml. Stop the heating, open the tap of the dropping funnel (C), disconnect the splash head (B) and wash the condenser (D) carefully, collecting the wash water in the flask (E). Finally disconnect the flask (E).

5.3.3 Titration

Carefully mix the solution contained in the flask (E) and in the two side bulbs, and back-titrate the excess of the standard volumetric sulphuric acid solution (3.2) with the standard volumetric sodium hydroxide solution (3.3).

During the titration, stir carefully to ensure that the solution is completely mixed.

6 EXPRESSION OF RESULTS

The ammoniacal nitrogen content, expressed as a percentage by mass of nitrogen (N), is given by the formula :

$$(V_1 - V_2) \times 0,007\ 004 \times \frac{500}{50} \times \frac{100}{m} = \frac{7,004 (V_1 - V_2)}{m}$$

where

V_1 is the volume, in millilitres, of the standard volumetric sodium hydroxide solution (3.3) used for the

back-titration of the excess of the standard volumetric sulphuric acid solution (3.2) placed in the flask (E) for the blank test;

V_2 is the volume, in millilitres, of the standard volumetric sodium hydroxide solution (3.3) used for the back-titration of the excess of the standard volumetric sulphuric acid solution (3.2) placed in the flask (E) for the determination;

m is the mass, in grams, of the test portion (5.1);

0,007 004 is the mass, in grams, of nitrogen corresponding to 1 ml of 0,5 N standard volumetric sulphuric acid solution.

NOTE — If the concentrations of the standard volumetric solutions are not exactly as specified in the list of reagents, appropriate corrections should be made.

7 TEST REPORT

The test report shall include the following particulars :

- a) the reference of the method used;
- b) the results and the method of expression used;
- c) any unusual features noted during the determination;
- d) any operation not included in this International Standard, or regarded as optional.

Dimensions in millimetres

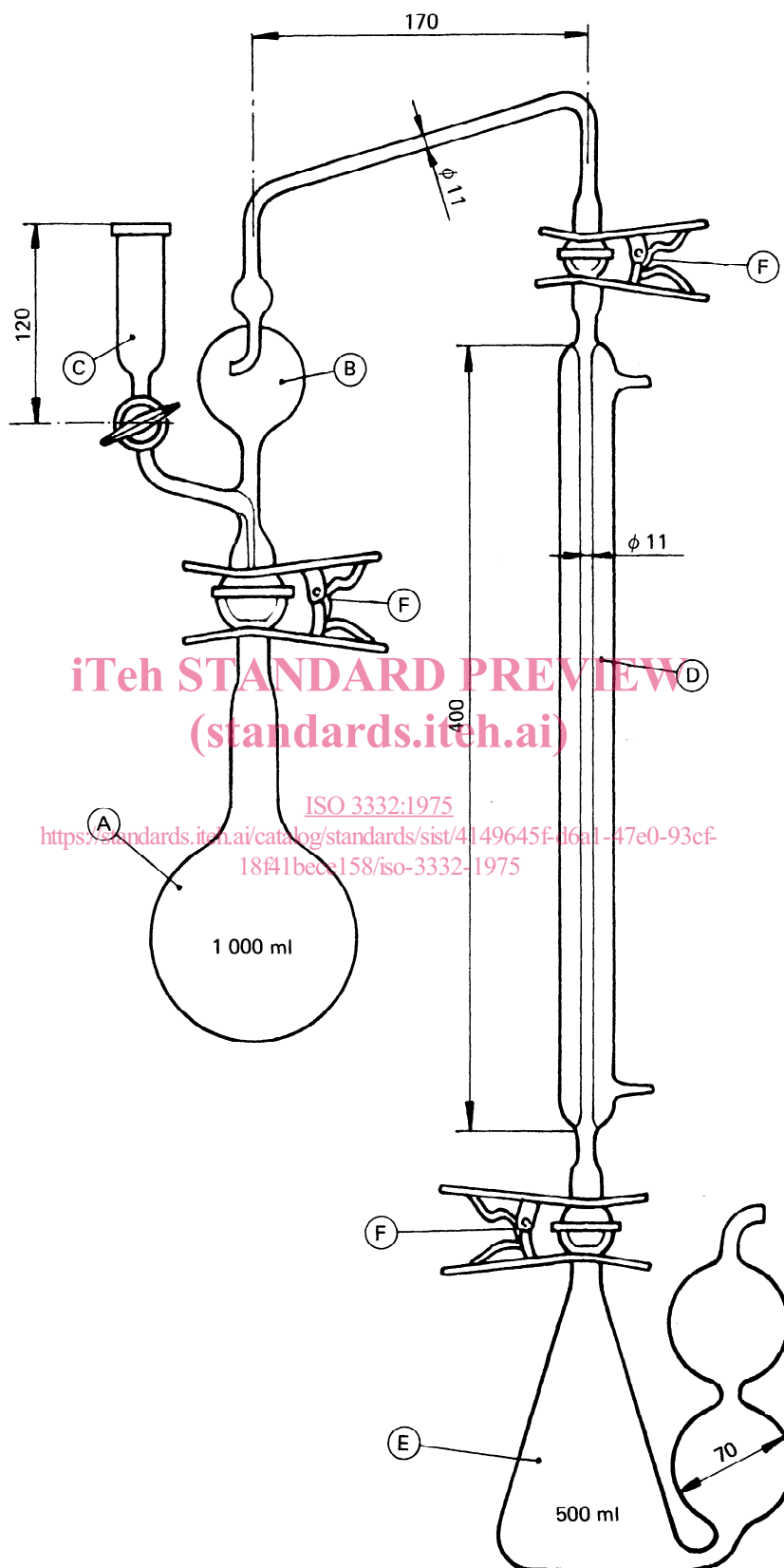

FIGURE – Typical distillation apparatus (4.1)

ANNEX

ISO PUBLICATIONS RELATING TO AMMONIUM SULPHATE FOR INDUSTRIAL USE

ISO 2992 – Determination of iron content – 2,2'-bipyridyl photometric method.

ISO 2993 – Determination of free acidity – Titrimetric method.

ISO 2994 – Determination of matter insoluble in water – Gravimetric method.

ISO 3332 – Determination of ammoniacal nitrogen content – Volumetric method after distillation.

ISO 3333 – Determination of copper content – Zinc dibenzylidithiocarbamate photometric method.

ISO 3694 – Determination of chlorides content – Potentiometric method.

iTeh STANDARD PREVIEW
(standards.iteh.ai)

[ISO 3332:1975](https://standards.iteh.ai/catalog/standards/sist/4149645f-d6a1-47e0-93cf-1841bece158/iso-3332-1975)

<https://standards.iteh.ai/catalog/standards/sist/4149645f-d6a1-47e0-93cf-1841bece158/iso-3332-1975>

iTeh STANDARD PREVIEW
(standards.iteh.ai)

This page intentionally left blank

[ISO 3332:1975](#)

<https://standards.iteh.ai/catalog/standards/sist/4149645f-d6a1-47e0-93cf-18f41bece158/iso-3332-1975>

iTeh STANDARD PREVIEW
(standards.iteh.ai)

This page intentionally left blank

[ISO 3332:1975](#)

<https://standards.iteh.ai/catalog/standards/sist/4149645f-d6a1-47e0-93cf-18f41bece158/iso-3332-1975>