



Designation: **C1279–09 C1279 – 13**

Standard Test Method for Non-Destructive Photoelastic Measurement of Edge and Surface Stresses in Annealed, Heat-Strengthened, and Fully Tempered Flat Glass¹

This standard is issued under the fixed designation C1279; the number immediately following the designation indicates the year of original adoption or, in the case of revision, the year of last revision. A number in parentheses indicates the year of last reappraisal. A superscript epsilon (ϵ) indicates an editorial change since the last revision or reappraisal.

1. Scope

1.1 This test method covers the determination of edge stresses and surface stresses in annealed, heat-strengthened, and fully tempered flat glass products.

1.2 This test method is non-destructive.

1.3 This test method uses transmitted light and is, therefore, applicable to light-transmitting glasses.

1.4 The test method is not applicable to chemically-tempered glass.

1.5 Using the procedure described, surface stresses can be measured only on the “tin” side of float glass.

1.6 Surface-stress measuring instruments are designed for a specific range of surface index of refraction.

1.7 The values stated in SI units are to be regarded as standard. No other units of measurement are included in this standard.

1.8 *This standard does not purport to address all of the safety concerns, if any, associated with its use. It is the responsibility of the user of this standard to establish appropriate safety and health practices and determine the applicability of regulatory limitations prior to use.*

2. Referenced Documents

2.1 *ASTM Standards:*²

[C158 Test Methods for Strength of Glass by Flexure \(Determination of Modulus of Rupture\)](#)

[C162 Terminology of Glass and Glass Products](#)

[C770 Test Method for Measurement of Glass Stress—Optical Coefficient](#)

[C1048 Specification for Heat-Strengthened and Fully Tempered Flat Glass](#)

[E691 Practice for Conducting an Interlaboratory Study to Determine the Precision of a Test Method](#)

2.2 *Other Documents:*

[Engineering Standards Manual](#)³

[“Surface and Edge Stress in Tempered Glass”](#)⁴

3. Terminology

3.1 *Definitions:*

3.1.1 *analyzer*—a polarizing element, typically positioned between the specimen being evaluated and the viewer.

3.1.2 *polarizer*—an optical assembly that transmits light vibrating in a single planar direction, typically positioned between a light source and the specimen being evaluated.

3.1.3 *retardation compensator*—an optical device, variants of which are used to quantify the optical retardation produced in transparent birefringent materials: typically positioned between the specimen being evaluated and the analyzer.

¹ This test method is under the jurisdiction of ASTM Committee C14 on Glass and Glass Products and is the direct responsibility of Subcommittee C14.08 on Flat Glass. Current edition approved Oct. 1, 2009. Published October 2009. Originally approved in 1994. Last previous edition approved in 2005 as C1279-05-09. DOI: 10.1520/C1279-09-10.1520/C1279-13.

² For referenced ASTM standards, visit the ASTM website, www.astm.org, or contact ASTM Customer Service at service@astm.org. For *Annual Book of ASTM Standards* volume information, refer to the standard's Document Summary page on the ASTM website.

³ Available from Glass Association of North America (GANA), 2925800 SW Wanamaker Drive, Jackson Street, Ste A, 1500, Topeka, Kansas 66614-5321-66612-1200. <http://www.glasswebsite.com>

⁴ Redner, A. S. and Voloshin, A. S., Proceedings of the Ninth International Conference on Experimental Mechanics, Denmark, 1990.

3.2 For definition of terms used in this test method, refer to Terminology C162.

4. Summary of Test Methods

4.1 Two test methods are described in this standard:

4.1.1 Procedure A—describes a test method for measuring surface stress using light propagating nearly parallel to the surface.

4.1.2 Procedure B—describes a test method for measuring edge-stress using light propagating in the direction perpendicular to the surface.

4.2 In both methods, the fundamental photoelastic concept is used. As a result of stresses, the material becomes optically anisotropic or birefringent. When polarized light propagates through such anisotropic materials, the differences in the speed of light rays vibrating along the maximum and minimum principal stress introduce a relative retardation between these rays. This relative retardation is proportional to the measured stresses, and can be accurately determined using compensators. For additional background see “Surface and Edge Stress in Tempered Glass”⁴.

5. Significance and Use

5.1 The strength and performance of heat-strengthened and fully-tempered glass is greatly affected by the surface and edge stress induced during the heat-treating process.

5.2 The edge and surface stress levels are specified in Specification C1048, in the Engineering Standards Manual³ of GANA Tempering Division and in foreign specifications.

5.3 This test method offers a direct and convenient way to non-destructively determine the residual state of stress on the surface and at the edge of annealed and heat-treated glass.

6. Principles of Operation

6.1 Procedure A: Measuring Surface Stress:

6.1.1 Measurement of surface stresses requires an optical apparatus that permits the injection of polarized light rays propagating in a thin layer adjacent to the surface (see Note 1). A prism is usually used for this purpose. The rays emerge at critical angle i_c . The photoelastic retardation due to the surface stresses, (see Fig. 1), is measured using a wedge-compensator.

6.1.2 The incident light beam should be arriving at the critical angle i_c and polarized at 45° to the entrance of the prism edge. A quartz wedge-compensator, W_c , placed in the path of emerging light adds a retardation, R_c , to the retardation R_s induced by stresses in the surface of the specimen. The analyzer, A , placed between the eyepiece, E , and the wedge-compensator, W_c , generates a visible set of fringes or lines of constant retardation R where

$$R = R_s + R_c \tag{1}$$

Since the specimen-induced retardation is proportional to the surface stress, S , and the path, t , we have:

$$R_s = C \cdot S \cdot t = C \cdot S \cdot ax \tag{2}$$

where:

R = is the relative retardation,

C = stress-optical constant (see Note 2),

S = surface stress in the direction perpendicular to the path, t

t = path of light traveling between the entrance and exit points 1, 2 (Fig. 1),

a = Geometrical factor, (depending upon the prism design) $a = t/x$. This constant is determined by the manufacturer.

6.1.3 The compensator adds its own retardation. It is linearly variable along its length y and is calculated as

$$R_c = b \cdot y \tag{3}$$

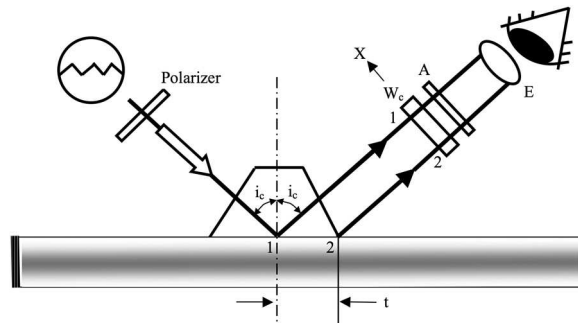

FIG. 1 Apparatus For Measuring Surface Stress

View of the Wedge, W_c

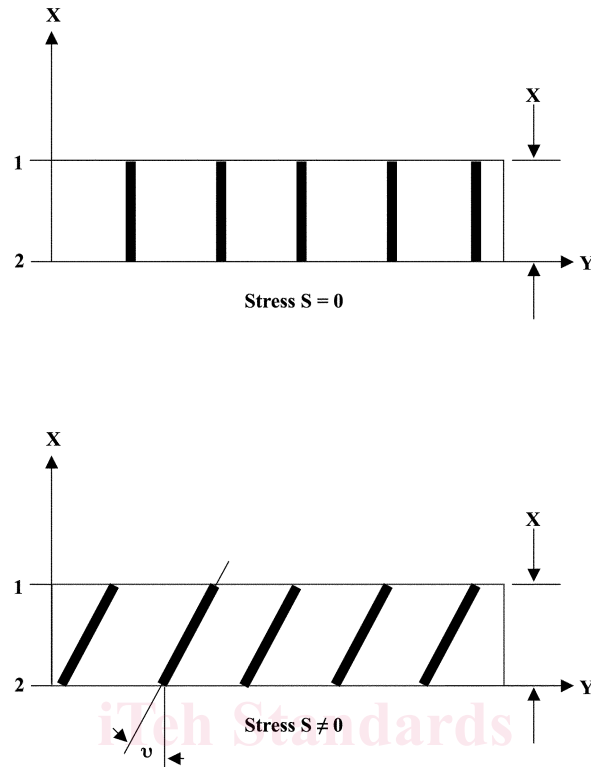

FIG. 1 Apparatus For Measuring Surface Stress (continued)

Where b is a constant, determined by the manufacturer of the compensator. The observer sees in the compensator plane a total retardation R .

$$R = R_s + R_c = a \cdot C \cdot S \cdot x + b \cdot y \quad (4)$$

6.1.4 The fringes (lines of $R = \text{Constant}$) are, therefore, tilted lines. (See Fig. 2). The angle θ is the tilt of these fringes relative to a plane containing the light path of Figs. 1 and 2. The measured stress is proportional to the tangent of the tilt angle θ , measured using a goniometer, and to an instrument calibration constant, K MPa, determined by the manufacturer.

$$\tan \theta = \frac{a \cdot C \cdot S}{b} \quad \text{and} \quad (5)$$

$$\text{Stress} = \frac{b}{Ca} \cdot \tan \theta = K \cdot \tan \theta$$

In the actual procedure (see 9.15.1 below) the operator measures the tilt angle θ of the observed set of fringes.

NOTE 1—The surface-stress measuring apparatus described in this section is manufactured by Strainoptic Technologies, Inc. in North Wales, Pennsylvania.

NOTE 2—The stress constant of float glass is typically 2.55 to 2.65 Brewsters. Calibration can be performed using one of the test methods described in Test Methods C770.

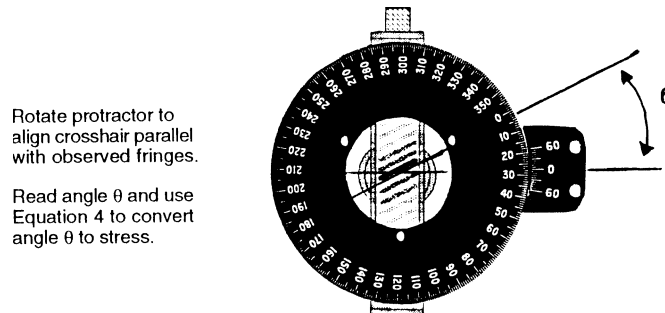

FIG. 2 Fringes Observed in the Plane of the Compensator

6.2 Procedure B: Measuring Edge Stress:

6.2.1 Measurement of edge stress is accomplished using a polarimeter equipped with a wedge-compensator, as shown schematically in Fig. 3.

6.2.2 The angle between the polarizer and the edge of the specimen must be 45° (see Fig. 3a), and the analyzer must be perpendicular to the polarizer. The overall magnification should be at least 20× to permit clear visibility of the reticle, and of photoelastic fringes near the edge. The reticle placed adjacent to the specimen must have graduations of 0.1 mm (0.004 in.) or smaller. The resolution of the compensator should be at least 5 nm, and the compensator should be calibrated by the manufacturer at 565 nm wavelength with results of calibration expressed in nm/div.

6.2.3 The compensator used could be of linear wedge type (Babinet) or uniform-field type (Babinet-Soleil). The linear-wedge type requires a reticle placed adjacent to the compensator wedge and a linear-motion scale, or lead screw, locating the wedge position with reference to the reticle.

6.2.4 The uniform field does not require a reticle, and must be equipped with a lead screw measuring the relative motion of its wedges.

7. Sampling

7.1 Procedure A: Measuring Surface Stress—The number of points to be measured are determined by either the product specification or by the following protocol described in Specification C1048.

7.2 Procedure B: Measuring Edge Stress—Readings must be obtained at the mid-span point of every edge.

8. Calibration and Standardization

8.1 A test bar is subjected to bending using traceably certified deadweights or calibrated load-cells to introduce surface stresses that can be calculated from the specimen geometry and forces applied. At a point in which the stresses are calculated, those same stresses also are measured using the instrument to be calibrated or verified. Since both the specimen dimension and the applied forces can be established accurately using traceable (primary) standards, the method permits a fully traceable calibration of the stress-measuring instrument.

8.2 The instrument to be calibrated is placed on the surface of the calibration specimen. Stresses at a point where the instrument is placed are calculated using expressions shown in Section 11. To increase the precision of measurement, several levels of stress are produced by applying forces incrementally. Measurement of stress using the instrument to be calibrated is repeated for each stress level and these measurements are used to calibrate the instrument.

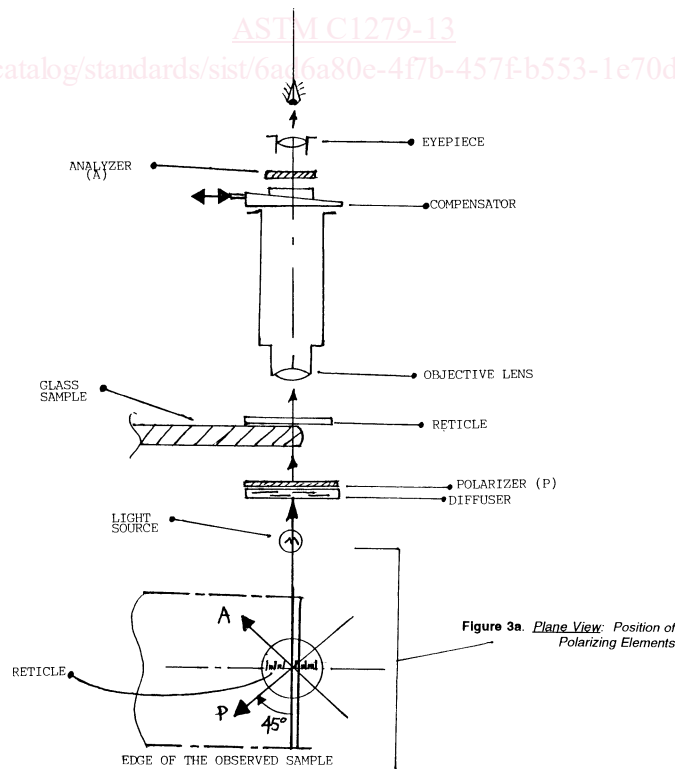

FIG. 3 Schematic of the Instrument for Measuring Edge Stress

9. Test Specimens and Loading Schemes

9.1 Two loading geometries can be practiced: cantilever and four-point bending.

9.2 *Cantilever-Beam Specimen (Fig. 4)*—the dimensions of the specimen used for cantilever loading should be selected within limits shown below:

- Thickness (t): 6 mm (0.22 in.) minimum,
- Width (W): $8t \leq W \leq 12t$,
- Length (L): 6W minimum,
- Distance to the point of measurement (L_0): 4W, and
- Clamped length: 1.5W

9.2.1 A heat-strengthened or tempered specimen, with polished edges is preferred, but annealed specimens can be used if the range of stress is less than 24.13 MPa (3500 psi).

9.3 *Four-Point Bending Specimen (Fig. 5)*—The four-point bending specimen should be preferred since it has uniform stress in the central loading zone. The dimensions of the specimen should be selected within the following limits:

- Thickness (t): minimum 2 mm (0.079 in.),
- Width (W): $8t \leq W \leq 12t$ (see Note 3),
- Length L_0 : 6W minimum,
- Gage length L_C section: 3W,
- Minimum overall length L: 12W, and
- Edges: Polished, no chips in the gage section, bevel less than 0.1t.

NOTE 3—When the thickness *t* is less than 6 mm, and width of the beam exceeds 12*t*, instead of the beam bending, plate bending equations should be used to calculate surface stress, or suitable corrections are required in the equations in 11.1. Barata⁵ and Ashwell⁶ show the correction procedures.

9.4 *Application of Forces*—Forces required must be calculated to eliminate possible breakage. Stresses must be estimated first using the equations in 9.1. A tempered specimen may be subjected to stress levels up to 10 000 psi (69 MPa). Using annealed specimens, the stress should remain at a safe level, typically below 3500 psi (24 MPa).

9.4.1 *Cantilever Specimen*—The specimen must be clamped securely using wood, plastic, or rubber-lined metal clamping surfaces, with rounded edges, as shown in Fig. 6. The forces can be applied using a calibrated testing machine or dead weights, by means of knife edges, to insure exact positioning of the line-of-loading B-B. The pad used for load application can be secured from slipping using high-friction materials. To eliminate possible twisting action, the knife edge should be narrow, or a steel ball used to center the point of application of force.

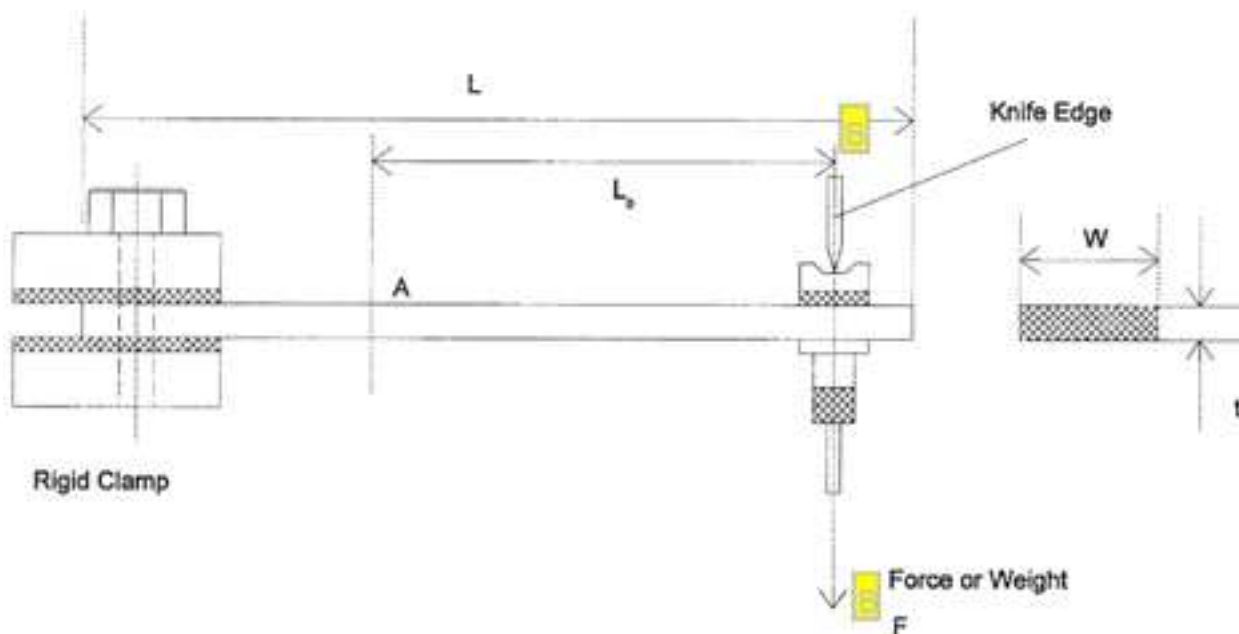

FIG. 4 Cantilever Beam Loading

⁵ Barata, F. I., "When Is a Beam a Plate?" American Ceramic Society Communications, May 1981.

⁶ Ashwell, D. G., "The Anticlastic Curvature of Rectangular Beams and Plates," Journal of Aeronautics, Vol 54, 1950, pp. 708-715.

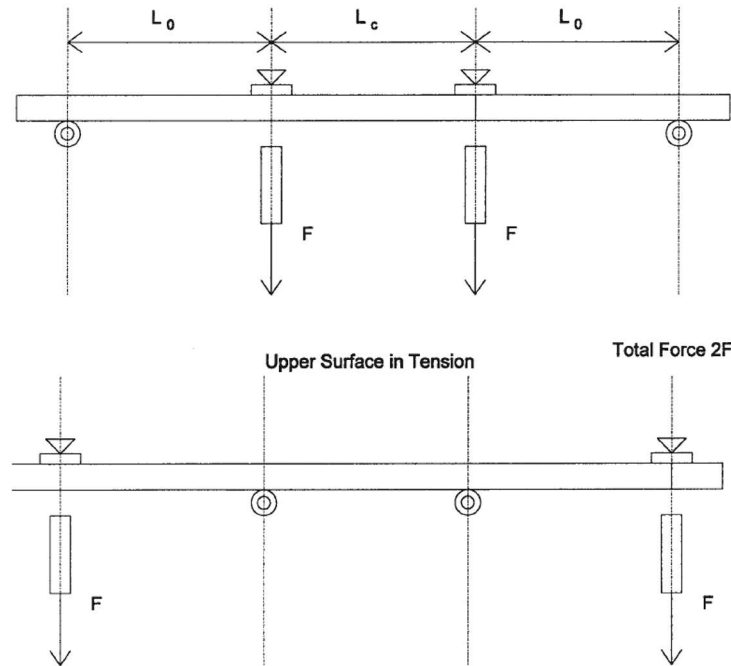

FIG. 5 Calibration Using Four-Point Bending

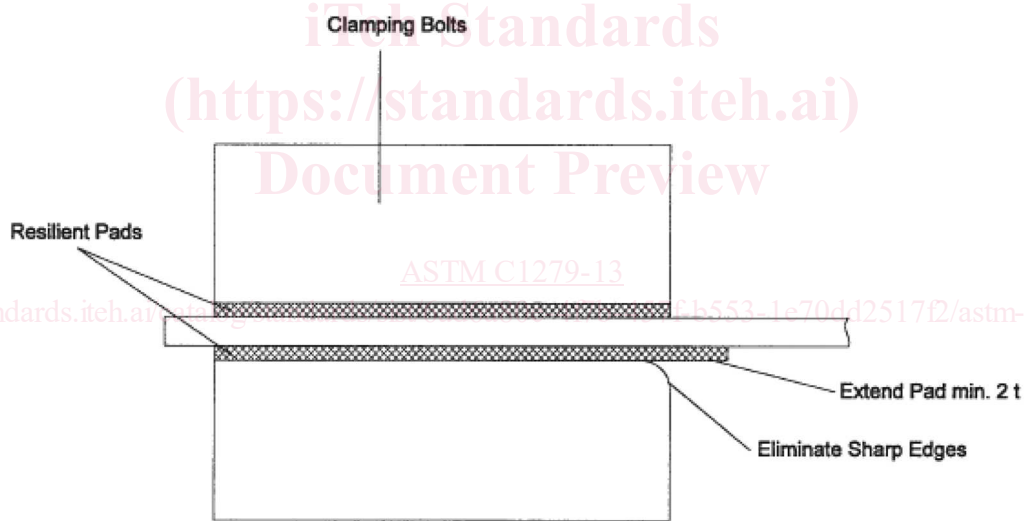

FIG. 6 Clamping of a Cantilever Beam

9.4.2 *Four-Point Bending Specimen*—In the case of four-point bending, the force must be applied equally at two points, and two articulated knives or roller supports are required to ascertain accurately the length L_0 and L_c . Particular precautions are required to insure that the end supports do not introduce a twist in the specimen, as a result of nonparallel support surfaces or nonflatness of the specimen itself. Fig. 5 illustrates the setup for application of forces to obtain tension and compression on the upper face. Test Methods C158 provides a description of support design.

10. Calibration Procedure

10.1 When calibrating a surface polarimeter, apply forces in five equal increments, using a testing machine or dead weight. When calibrating a critical angle measuring instrument, at least ten increments are needed, and a tempered specimen must be used.

10.2 For each incremental loading, including zero, obtain the instrument reading. Repeat the reading at least three times, and average the readings. When calibrating a surface polarimeter, measure the fringe tilt θ . When calibrating a differential refractometer, measure the differential angle using a micrometer reticle, and read the distance between the borders of illuminated zones at mutually perpendicular polarization in accordance with instrument manual.