



Designation: **D7545 – 09 D7545 – 13**

## Standard Test Method for Oxidation Stability of Middle Distillate Fuels—Rapid Small Scale Oxidation Test (RSSOT)<sup>1</sup>

This standard is issued under the fixed designation D7545; the number immediately following the designation indicates the year of original adoption or, in the case of revision, the year of last revision. A number in parentheses indicates the year of last reapproval. A superscript epsilon ( $\epsilon$ ) indicates an editorial change since the last revision or reapproval.

### 1. Scope—Scope\*

1.1 This laboratory test method covers a quantitative determination of the stability of middle distillate fuels such as diesel fuels and heating oils, with up to 100% biodiesel, under accelerated oxidation conditions, by an automatic instrument.

1.2 This test method is designed for products complying with Specification **D975** on Diesel Fuel, Grades No. 1D and 2D; Specification **D396** on Burner Fuel, Grades No. 1 and No. 2; Specification **D6751** on Biodiesel, B100, and Specification **D7467** on Diesel Fuel Oil, B6 to B20.

1.3 This test method measures the induction period, under specified conditions, which can be used as an indication of the oxidation and storage stability of middle distillate fuels.

1.4 The values stated in SI units are to be regarded as standard. No other units of measurement are included in this standard.

1.5 *This standard does not purport to address all of the safety concerns, if any, associated with its use. It is the responsibility of the user of this standard to establish appropriate safety and health practices and determine the applicability of regulatory limitations prior to use.*

### 2. Referenced Documents

2.1 *ASTM Standards:*<sup>2</sup>

**D396** Specification for Fuel Oils

**D975** Specification for Diesel Fuel Oils

**D4057** Practice for Manual Sampling of Petroleum and Petroleum Products

**D4177** Practice for Automatic Sampling of Petroleum and Petroleum Products

**D6751** Specification for Biodiesel Fuel Blend Stock (B100) for Middle Distillate Fuels

**D7467** Specification for Diesel Fuel Oil, Biodiesel Blend (B6 to B20)<sup>2</sup>

2.2 *Other Standards:*

**CEN/TR 16366:2012** Liquid Petroleum Products—Middle Distillates and Fatty Acid Methyl Ester (FAME) Fuels and Blends—Round Robin Report on Applicability of Rapid Small Scale Oxidation Test Method<sup>3</sup>

**EN 590** Automotive Fuels—Diesel—Requirements and Test Methods<sup>3</sup>

**EN 16091** Liquid Petroleum Products—Middle Distillates and Fatty Acid Methyl Ester (FAME) Fuels and Blends—Determination of Oxidation Stability by Rapid Small Scale Oxidation Method<sup>3</sup>

**ISO 4259** Petroleum Products—Determination and Application of Precision Data in Relation to Methods of Test<sup>4</sup>

### 3. Terminology

3.1 *Definitions of Terms Specific to This Standard:*

3.1.1 *break point, n*—pressure in the test apparatus which is 10 % below the maximum pressure of the actual test run.

3.1.2 *induction period, n*—time elapsed between starting the heating procedure of the sample vessel and the break point, measured in minutes.

<sup>1</sup> This test method is under the jurisdiction of ASTM Committee **D02** on Petroleum Products—Products, Liquid Fuels, and Lubricants and is the direct responsibility of Subcommittee **D02.14** on Stability and Cleanliness of Liquid Fuels.

Current edition approved July 1, 2009/Oct. 1, 2013. Published August 2009/October 2013. Originally approved in 2009. Last previous edition approved in 2009 as **D7545 – 09**. DOI: 10.1520/D7545-09.10.1520/D7545-13.

<sup>2</sup> For referenced ASTM standards, visit the ASTM website, [www.astm.org](http://www.astm.org), or contact ASTM Customer Service at [service@astm.org](mailto:service@astm.org). For *Annual Book of ASTM Standards* volume information, refer to the standard's Document Summary page on the ASTM website.

<sup>3</sup> Available from European Committee for Standardization (CEN), Avenue Marnix 17, B-1000, Brussels, Belgium, <http://www.cen.eu>.

<sup>4</sup> Available from International Organization for Standardization (ISO), 1, ch. de la Voie-Creuse, CP 56, CH-1211 Geneva 20, Switzerland, <http://www.iso.org>.

\*A Summary of Changes section appears at the end of this standard

#### 4. Summary of Test Method

4.1 ~~A 5-mL~~ 5 mL sample is introduced into a pressure vessel which is then charged with oxygen to 700 kPa at ambient temperature. The test is initiated by starting the heater and heating the pressure vessel to a temperature of 140°C.

4.2 The pressure is recorded continuously until the breakpoint is reached. Alternatively, the test may be terminated when a minimum specification requirement is reached.

#### 5. Significance and Use

5.1 The induction period may be used as an indication of the oxidation and storage stability of middle distillate fuel.

5.2 Compared to some other oxidation and storage stability test methods, this method uses a small sample and gives a result in a short time period.

#### 6. Apparatus

6.1 *General*—This test method uses an automatically controlled oxidation tester<sup>5</sup> (see Fig. 1) comprising an oxidation pressure vessel containing a test sample cup capable of being rapidly heated, fitted with a pressure sensor capable of measuring pressures up to 2000 kPa and a temperature sensor capable of reading to 0.1°C.

6.1.1 Pressure and temperature in the oxidation vessel are recorded continuously during the test. The oxidation pressure vessel is fitted with filling and relief-valves and a means of automatically releasing the pressure. The integrated cooling fan cools the pressure vessel from the test temperature to ambient temperature by a flow of air. See Annex A1 for detailed information.

6.2 *Volumetric Device*—Clean and free from contaminations of previous samples, capable of delivering  $5.0 \pm 0.1$  mL.

6.3 *Temperature Calibration Equipment*—Comprising a cover and a temperature calibration sensor (Fig. 2). The temperature calibration sensor is fixed to a depth of  $15 \pm 0.5$  mm. The temperature calibration sensor, calibrated to the nearest 0.1°C, is calibrated by an approved calibration service, such as one that is traceable to the National Institute of Standards and Technology (NIST) or to a national authority in the country in which the equipment is used or manufactured.

6.4 *Pressure Calibration Equipment*—Comprising a pressure calibration sensor (Fig. 3). The pressure calibration sensor is calibrated to the nearest 10 kPa by an approved calibration service, such as one that is traceable to the National Institute of Standards and Technology (NIST) or to a national authority in the country in which the equipment is used or manufactured.

#### 7. Reagents and Materials

7.1 Solvent for the removal of oxidation residues from the test vessel. The solvent shall be of suitable purity to leave no residue on the apparatus. Ethanol of 94% minimum purity has been found to be suitable. Other solvents, such as a mixture of equal volumes of toluene and acetone, may be used if shown to meet the requirements for the removal of oxidation residues from the test vessel without leaving any residue in the sample test cup.

7.2 *Oxygen*—Commercially available extra-dry oxygen of not less than 99.6% purity.

7.3 *Lint-free Cleaning Tissue*—For sensitive surfaces and that will not scratch the surface.

7.4 “O-ring” Seal—See A1.2.

7.5 *Temperature Calibration Fluid*—Stable middle distillate liquid with a flash point above +60°C and a boiling point above +150°C.

#### 8. Hazards

8.1 (**Warning**—To provide protection against possible explosive rupture of the pressure vessel and hazards relating to hot and flammable fuels, the apparatus shall be operated behind an appropriate safety shield.)

#### 9. Sampling

9.1 Sample in accordance with Practice D4057 or D4177.

#### 10. Preparation of Apparatus

10.1 Remove the previous sample by means of a pipette or similar device.

10.2 Remove the used “O-ring” seal and discard.

<sup>5</sup> The sole source of supply of the apparatus known to the committee at this time is Petrotest PetroOXY-Anton Paar's PetroOxy apparatus, available from Petrotest-Instruments GmbH & Co, Ludwig-Erhard-Ring 13, 15827 Dahlewitz, Germany, [www.petrotest.com](http://www.petrotest.com). Anton Paar ProveTec GmbH, Ludwig-Erhard-Ring 13, 15827 Dahlewitz, Germany. If you are aware of alternative suppliers, please provide this information to ASTM International Headquarters. Your comments will receive careful consideration at a meeting of the responsible technical committee,<sup>1</sup> which you may attend.

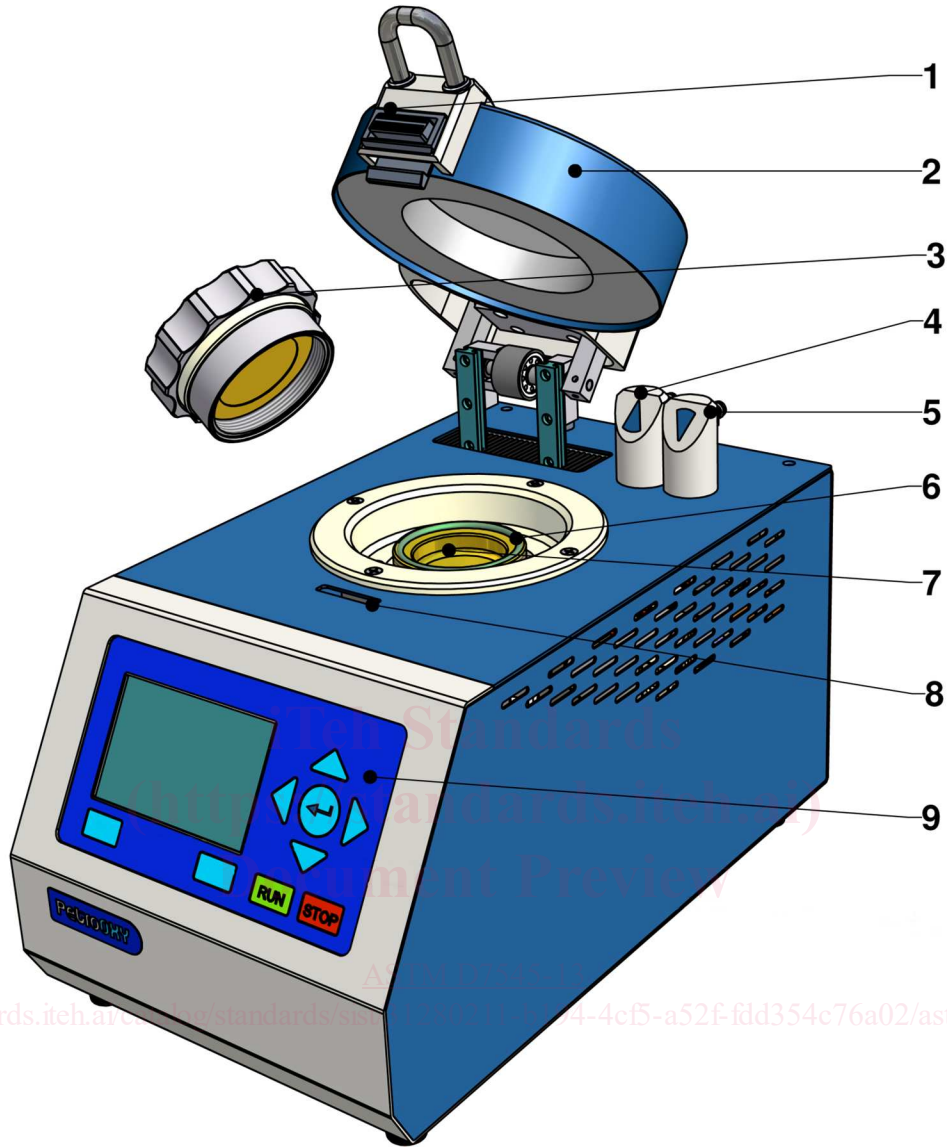

1. Unlocking mechanism for insulating hood
2. Safety and insulating hood
3. Screw cap for closing the test container
4. Oxygen outlet
5. Oxygen inlet
6. "O-ring" seal for test sample cup
7. Test sample cup
8. Locking mechanism for insulating hood
9. Operating panel with display

**FIG. 1 Schematic of Apparatus for Rapid Small Scale Oxidation Test**

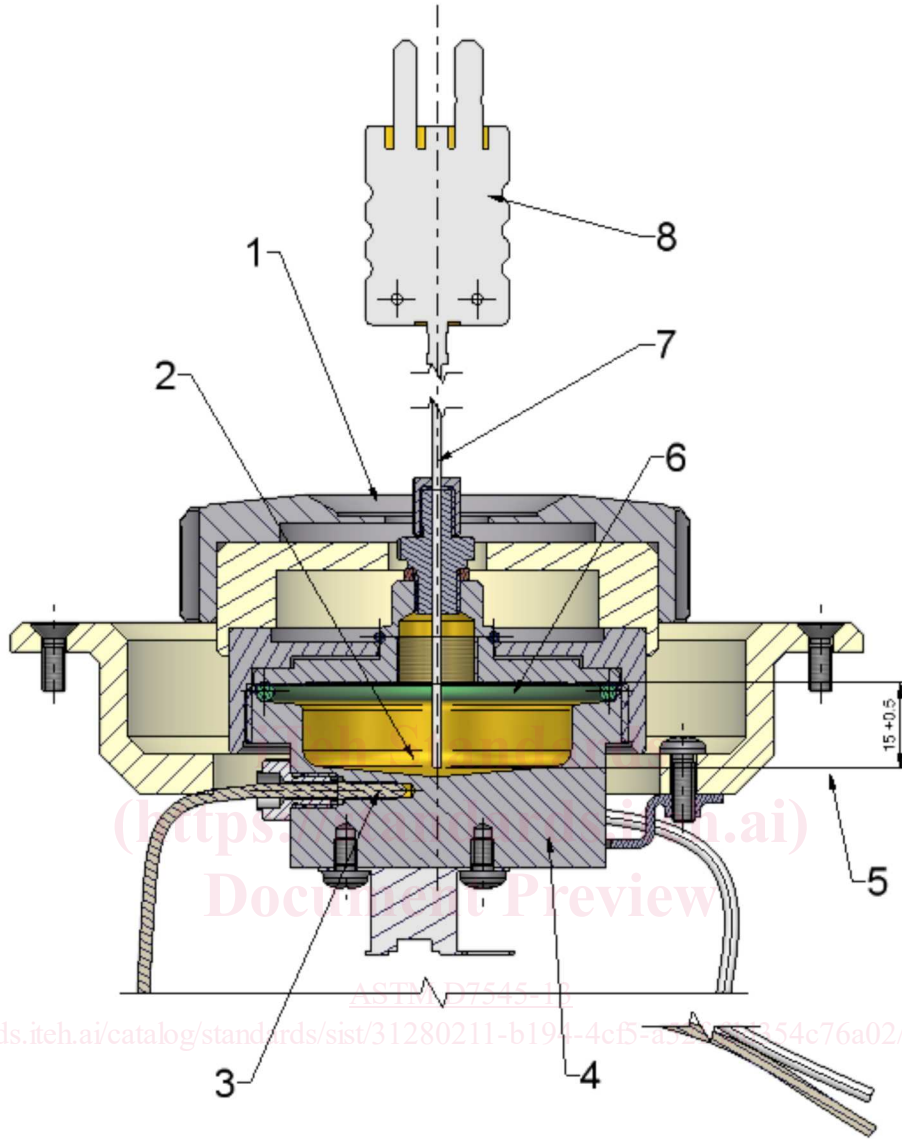

- 1- Calibration cover with duct for temperature calibration sensor
- 2- Calibration fluid
- 3- Temperature sensor for block temperature
- 4- Heating block
- 5- Immersion depth of temperature calibration sensor and bottom of calibration cover
- 6- Seal
- 7- Temperature calibration sensor
- 8- Connector plug to measuring device

**FIG. 2 Temperature Calibration Equipment**

NOTE 1—To avoid contamination of the new test, it is necessary to discard the used “O-ring” seal, because it might be soaked with oxidation products from the previous test.

10.3 Wipe the test sample cup, the seal groove and the cover of the test vessel with lint-free cleaning tissue (7.3) soaked with solvent until free of gum or other oxidation residues.

10.4 Allow the test sample cup and cover to dry in air and visually inspect for cleanliness.

NOTE 2—Compressed air is generally unsuitable to speed up evaporation of solvent because it can contain traces of oil that could contaminate the next test.

10.5 Insert a new “O-ring” seal.