



Designation: ~~D2719–89 (Reapproved 2007)~~ D2719 – 13

Standard Test Methods for Structural Panels in Shear Through-the-Thickness¹

This standard is issued under the fixed designation D2719; the number immediately following the designation indicates the year of original adoption or, in the case of revision, the year of last revision. A number in parentheses indicates the year of last reapproval. A superscript epsilon (ϵ) indicates an editorial change since the last revision or reapproval.

1. Scope

1.1 These test methods determine the shear through-the-thickness properties of structural panels associated with shear distortion of the major axis. Structural panels in use include plywood, ~~wafer board~~, oriented strand board, and composites of veneer and of wood based layers. Three test methods are included which differ somewhat in their application:

Test Method	Section
A. Small Panel Shear Test	5
B. Large Panel Shear Test	6
C. Two Rail Shear Test	7

The choice of test method will be determined in part by the purpose of the tests, characteristics of test material, and equipment availability. In general, Test Method B or C for large specimens is preferred when equipment, amount of test material, and experimental plan permit.

1.1.1 *Test Method A: Small Panel Shear Test*—This test method is suitable for testing small samples of uniform material including investigations of the effects of grain direction or orientation and of many raw materials and manufacturing process variables which influence shear properties uniformly throughout the specimen. The test method is unsuited for determining effects of grade and manufacturing features such as density variations, knots, and core gaps within the specimen.

1.1.2 *Test Method B: Large Panel Shear Test*—This test method is regarded as giving the most accurate modulus of rigidity and is therefore recommended for elastic tests of materials to be used in stress analysis studies of test structures. This test method also yields excellent shear strength values for clear material. However, in spite of the large size of the specimen, failures generally occur only in narrow zones at the perimeter of the test area. This characteristic, a result of the heavy perimeter framing, causes this test method to be generally unsuited for determining grade and manufacturing effects such as density variations, core gaps, and knots that are not uniformly distributed throughout the panel. Generally, only in cases where effects of these factors under conditions of heavy perimeter framing are desired, should the test method be applied.

1.1.3 *Test Method C: Two-Rail Shear Test*— This test method is applicable to a wide variety of materials and problems. The specimen fabrication and test procedures are somewhat simpler than in Test Methods A and B. The specimen is free to shear parallel to its 24-in.(610-mm) length dimension anywhere within the 8-in. (203-mm) width between rails. Thus, the test method is well suited for determining grade and manufacturing effects such as core gaps and knots occupying and affecting small areas. The test method is not so ideally suited for determination of modulus of rigidity, but when adjusted for strain distribution effects, values approximating those obtained by Test Method B result. The test method simulates effects of heavy framing when expected planes of weakness are oriented perpendicular to rails and no framing at all when parallel to rails.

NOTE 1—A smaller scale version based on the principles of this two rail shear method is contained in Test Methods D1037 section 27. The results from Test Methods D1037 section 27 may not be equivalent to the results from Test Methods D2719 Method C.

1.2 Significant differences, moderate to small in magnitude, among the three test methods have been found to exist when these test methods are applied to plywood of clear straight-grained veneers. Therefore, when comparisons are made among test results, it is recommended that the same test method be used throughout.

1.3 *This standard does not purport to address all of the safety concerns, if any, associated with its use. It is the responsibility of the user of this standard to establish appropriate safety and health practices and determine the applicability of regulatory limitations prior to use.*

¹ These test methods are under the jurisdiction of ASTM Committee D07 on Wood and are the direct responsibility of Subcommittee D07.03 on Panel Products. Current edition approved April 1, 2007. Oct. 1, 2013. Published April 2007. October 2013. Originally approved in 1969. Last previous edition approved in 2004, 2007 as D2719 – 89 (2004), (2007). DOI: 10.1520/D2719-89R07.10.1520/D2719-13.

2. Referenced Documents

2.1 ASTM Standards:²

D1037 Test Methods for Evaluating Properties of Wood-Base Fiber and Particle Panel Materials

D2395 Test Methods for Specific Gravity of Wood and Wood-Based Materials

D4442 Test Methods for Direct Moisture Content Measurement of Wood and Wood-Base Materials

3. Significance and Use

3.1 The strength and modulus of rigidity of structural panels in shear through-the-thickness obtained by these test methods are required for the rigorous design of many lumber-panel structural components such as trusses with panel gussets, box beams, folded plate roofs, and space plane structures, as well as floor and roof diaphragms, and shear walls. These properties are of secondary importance in typical roof deck and sheathing applications, and in crates and shipping containers.

3.2 Veneer produced by slicing or rotary peeling may contain fine checks or separations parallel to the grain on the knife side of the veneer that are produced as the knife is forced through the wood. These checks are termed “knife checks” to distinguish them from occasional checks that may be formed on the opposite side of the veneer by forces at the compression bar, and from checks caused by drying. Average depth of knife checks has been found to strongly influence shear properties in plywood panels and may be of significance in veneer incorporated in composite panels. Measurement of depth of knife checks is recommended in these test methods.

3.3 To control or define other variables influencing shear properties, these test methods require determination of moisture content and elapsed time to failure. The conditioning of test material in controlled atmosphere and determination of specific gravity are recommended.

4. Control of Moisture Content

4.1 Structural panel samples to be tested at a specific temperature/relative humidity shall be conditioned to approximate constant weight in controlled atmospheric conditions before gluing wood rails. Conditioning of fabricated specimens at the same temperature and relative humidity shall be continued until the adhesive has cured sufficiently to ensure adequate bond strength. For approximating moisture conditions of structural panels used under dry conditions, a relative humidity of $65 \pm 2\%$ at a temperature of $68 \pm 6^\circ\text{F}$ ($20 \pm 3^\circ\text{C}$) is recommended.

5. Test Method A—Small Panel Shear Test

5.1 Summary—A specimen having a square shear area bounded on each side by solid wood blocks glued to both sides of the specimen is loaded in compression along one diagonal in a conventional testing machine. Forces are applied to the glued-on blocks through a roller bracket assembly which causes the resultant forces to act collinearly with the edge of the shear test area. This loading method most nearly produces uniform pure shear. Shear strength is determined from maximum load, and modulus of rigidity may be calculated from measurements of compression strain along the compression diagonal of the specimen.

5.2 Test Specimen—Dimensions shown in Fig. 1 of the panel specimen and reinforcing blocks depend upon panel thickness. Distance between blocks, L , shall not exceed 20 times specimen thickness, and block width and thickness shall not be less than 5 and 2.5 times specimen thickness, respectively. Reinforcing blocks shall be of birch, maple, or other wood of similar strength

² For referenced ASTM standards, visit the ASTM website, www.astm.org, or contact ASTM Customer Service at service@astm.org. For Annual Book of ASTM Standards volume information, refer to the standard’s Document Summary page on the ASTM website.

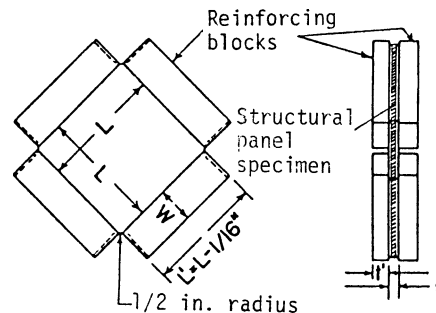

Metric Equivalents

in.	1/16	1/2
mm	1.6	12.7

FIG. 1 Small Panel Shear Specimen and Dimensions

and rigidity. The average of specimen thickness at two diagonally opposite corners and the dimensions of the shear area inside the reinforcing blocks shall be determined and recorded to the nearest 0.3 % or 0.001 in. (0.025 mm), whichever is larger.

5.3 *Loading*—Apply the load by special steel loading blocks which articulate with the rollers and pins attached to the test specimen. The angle between faces of the loading block shall be 90° and between each face and the base the angle shall be 45°. A spherical bearing block, preferably of the suspended, self-aligning type, shall be employed in the loading system. Apply the load continuously throughout the test with a uniform motion of the movable head of the testing machine equal to 0.0025 in./in. of test area diagonal length/min (0.0025 mm/mm/min) corresponding to a shear strain rate of 0.005 in./in./min (0.005 mm/mm/min) within a permissible variation of ±25 %.

5.3.1 Load each of the eight reinforcing blocks through roller brackets clamped to the reinforcing block across its width or attached by other means and applying a compressive force to the end of the reinforcing block through a surface contact area of at least 0.75 in.² (484 mm²). These bearing surfaces shall be firmly seated against the ends of their respective reinforcing blocks during assembly. Rollers shall be centered at the inner edge of the reinforcing block and 1.25 in. (31.8 mm) from the loaded end of the reinforcing block. Moderate clamping pressure holding brackets to the reinforcing blocks applied perpendicular to the plane of the panel is permitted but shall not be excessive.

5.3.1.1 Fig. 2 illustrates detail of suitable roller brackets and their method of attachment to the reinforcing blocks with small wood wedges. Fig. 3 shows a specimen loaded by means of roller brackets, and Fig. 4 gives working drawings for these brackets. Brackets are clamped across the width of the reinforcing blocks by driving small wedges between a projection on the bracket and the reinforcing block. The clamping bolt is used to apply moderate clamping pressure perpendicular to the plane of the specimen. Other bracket devices conforming to the requirements of 5.3.1 are permitted but shall be described in detail in the report of test results.

5.3.1.2 Measure the elapsed time from initiation of loading to the maximum load and record to the nearest ½ min.

5.4 *Measurement of Deformation*—When deformation data are desired for calculation of elastic properties, strain-measuring devices having minimum gage length of 1 in. (25 mm) shall be attached to both sides of the specimen and shall measure compression strain of the vertical (or compression) diagonal, the gages being centered at its midpoint on each side. A larger gage

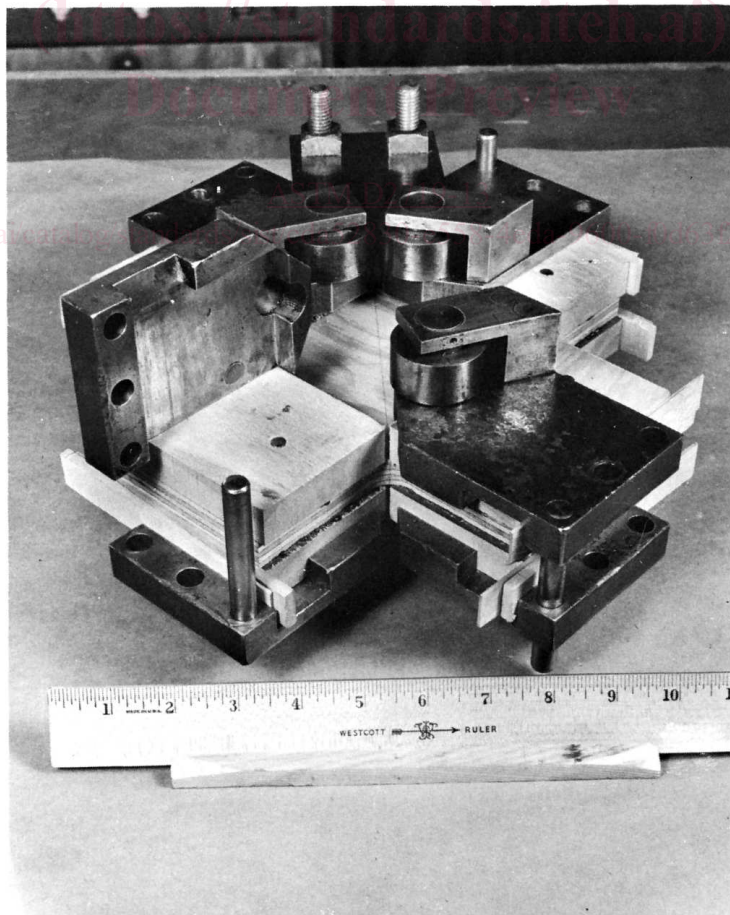

FIG. 2 Small Panel Shear Specimen with Roller Brackets

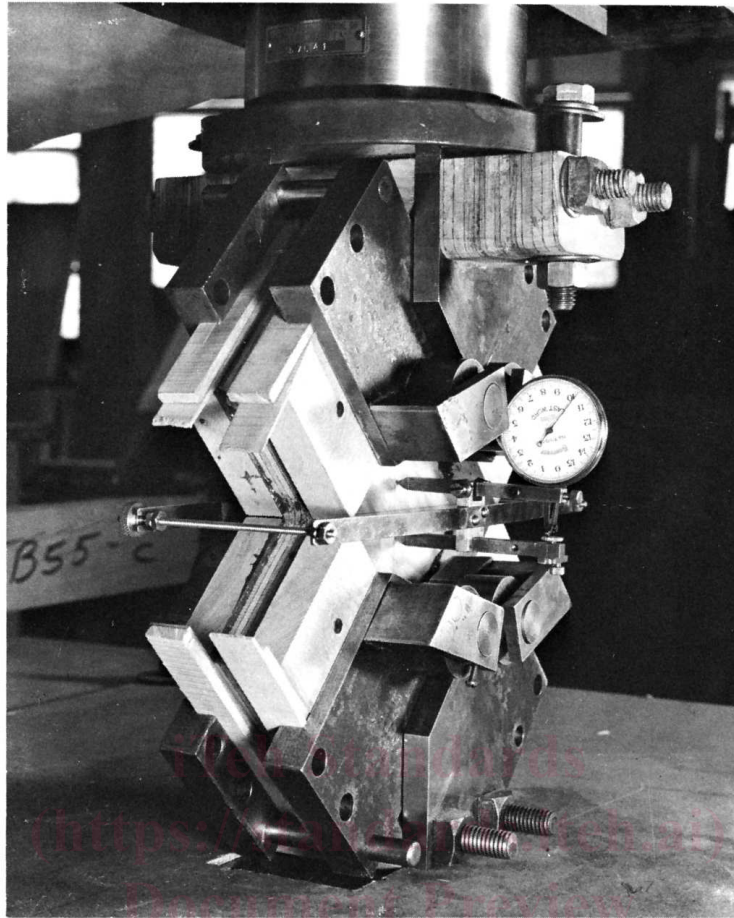

FIG. 3 Small Panel Shear Specimen with Loading and Strain-Measuring Apparatus Placed in Testing Machine

ASTM D2719-13

length is preferred but shall not exceed one half the length of the diagonal. Instruments and the accuracy of their recording shall be to the nearest 0.0001 in. (0.0025 mm) or 2 % of expected ultimate strain, whichever is smaller. Strain readings of the two gages shall be averaged for computation of elastic properties.

5.5 Calculation:

5.5.1 Calculate the maximum shear stress or shear stress at the proportional limit as follows:

$$T = 0.707 (P/Lt) \tag{1}$$

where:

- T = shear stress, psi (N/m²),
- P = load (force), lbf (N),
- L = length of side of shear area, in. (m), (Fig. 1), and
- t = thickness of shear specimen, in. (m).

5.5.2 Calculate modulus of rigidity from deformation data as follows:

$$G = 0.3536 (P/\Delta)[L_1 / (L \cdot t)] \tag{2}$$

where:

- G = modulus of rigidity, psi (N/m²),
- P/Δ = slope of force/deformation curve, lbf/in. (N/m),
- L_1 = gage length, in. (m), and
- t = thickness of shear specimen, in. (m).

6. Test Method B—Large Panel Shear Test

6.1 Summary—A specimen having a square shear area is loaded through heavy lumber rails glued to both sides of the specimen at all four edges of the shear area. Loading by a system of pins and yokes applies forces to the rails having a resultant acting at

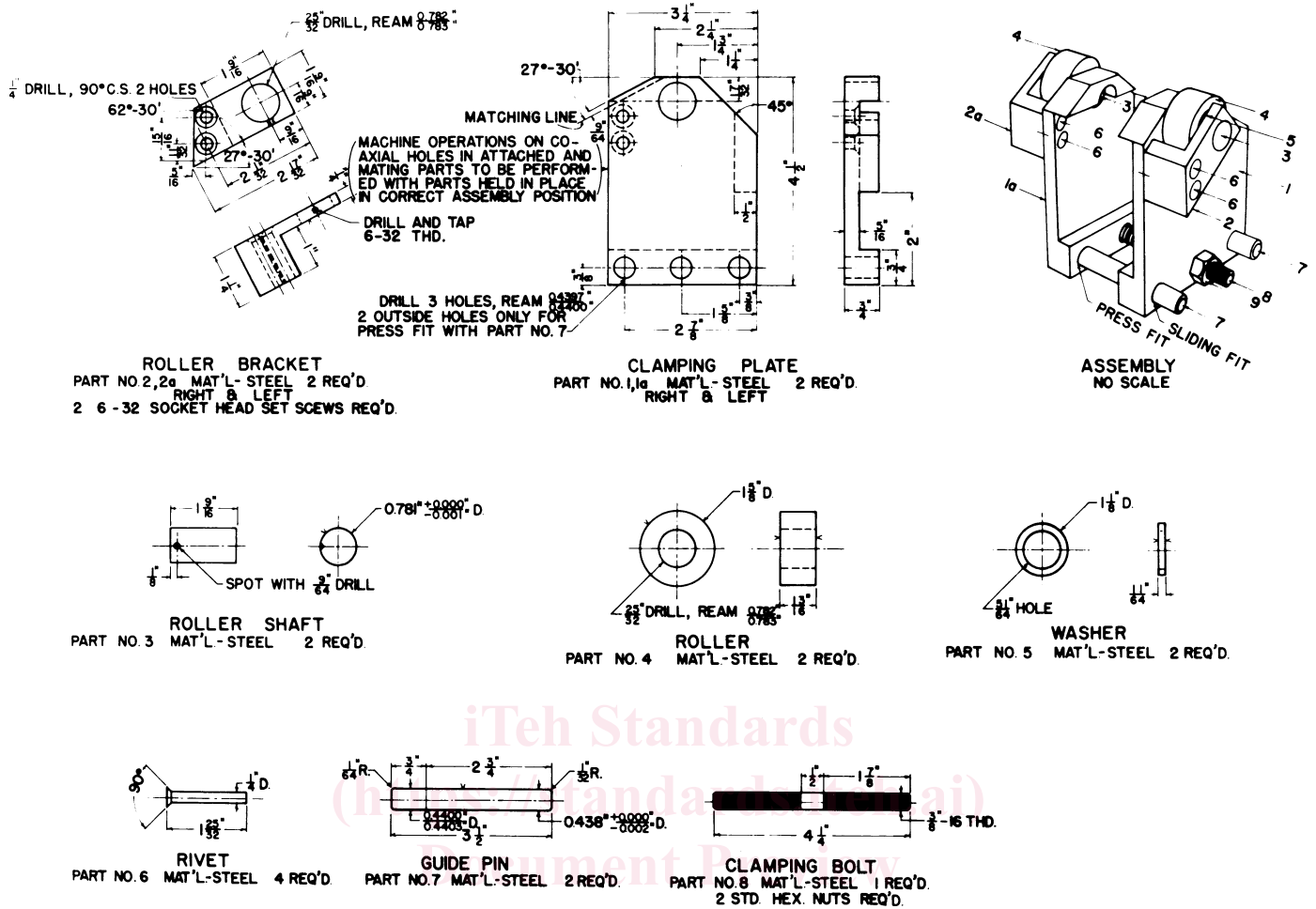

FIG. 4 Working Drawings for Small Panel Shear Test Loading Apparatus

<https://standards.iteh.ai/catalog/standards/sist/eda52830-e558-4eda-9600-f0d63f2a0305/astm-d2719-13>
the inside edge of the shear area. Maximum shear strength is determined from maximum load and modulus of rigidity from elongation of the tension diagonal and corresponding loads.

6.2 *Test Specimens*—Fig. 5 gives detail of the specimen as well as a suitable loading method. Shear area of the specimen shall not be less than 24 in. (610 mm) on a side, and shall not exceed 48 times total specimen thickness. When structural panels less than 1/2 in. (12.7 mm) thick or less than 1/48 the side of the shear area is to be tested for shear strength, two or more thicknesses of structural panels may be glued together (major axis parallel) to form a test panel of the required thickness. Specimens to be tested for modulus of rigidity only may be of lesser thickness provided sufficient data can be obtained before the test is halted due to initiation of buckling. Lumber rails having a length equal to the side of the shear area, thickness not less than 1/25 and width not less than 1/6 the length of one side of the shear area shall be glued to the structural panels with a rigid adhesive. Wider rails may be necessary to prevent rolling shear failures between thick or high-strength panels and the rails. Corners of the structural panels specimen shall be notched with the inside corner of the notch provided with a fillet of 1/2-in. (12.7-mm) radius as shown in Fig. 5. Ends of the rails to which loads are applied shall form a flat plane perpendicular to the plane of the specimen. Use of a jig to position rails accurately at the time of assembly or a light saw cut across the end of both rails after assembly may be helpful. Depending upon the method of deformation measurement, holes for gage pins may be needed as illustrated in Fig. 5. Average specimen thickness shall be determined from measurements at each corner of the shear area to an accuracy of 0.001 in. (0.025 mm). Width and length of the shear area shall be measured to an accuracy of 0.01 in. (0.25 mm).

6.3 *Loading*—Load the specimen loading jig assembly in tension. The resultant of forces applied to a pair of rails shall be a single force acting at, and parallel to, the edge of the shear area. If the ends of rails are compression loaded, the jigs shall restrain any tendency for the rails to deflect laterally from the plane of the specimen. Fig. 6 shows the loading forces, their resultants, and their components. Any lateral forces applied to the rails parallel to the plane of the specimen or any lateral component parallel to the plane of the specimen of a force applied to the rails shall not exceed 1/8 of the axial force component.

6.3.1 Suitable loading equipment is illustrated in Fig. 5 and Fig. 7. Major compression forces are applied by yokes to the ends of the rails at a slight angle to the rail axis through bearing plates. At its other end, a pin having a notched end centers the pin and

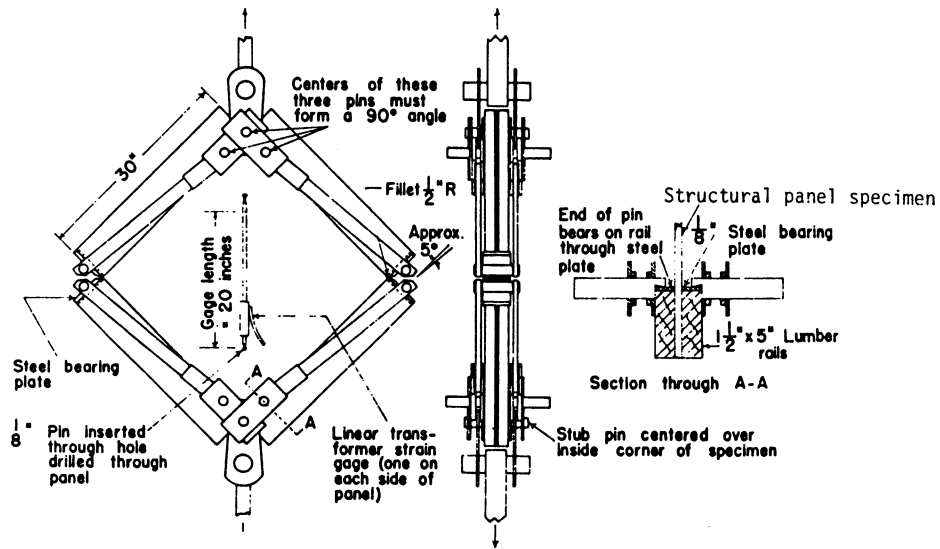

Metric Equivalents

in.	1/8	1/2	1 1/2	5	30
mm	3.2	12.7	38.1	127	762

FIG. 5 Large Panel Shear Test Specimen and Test Equipment

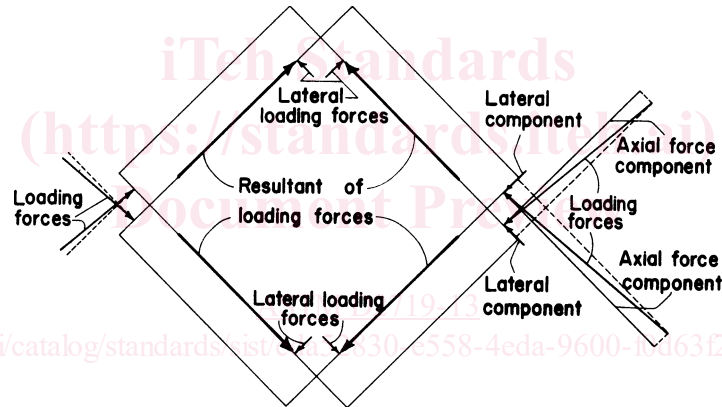

FIG. 6 Specimen Loading Forces, Their Components, and Their Resultants in the Large Panel-Shear Test

yoke over the inside edge of the rail. Forces acting at, and parallel to, the inner edge of the rail are applied to these pins by short links. At its other end, the link connects to a pin centered at the corner of the shear area to which the link loading the adjacent rail is also connected. This pin is loaded through a third link connecting to the test machine crosshead.

6.3.2 Load the specimen by constant motion of the movable crosshead throughout the test such that the shear area of the specimen is strained at the rate of 0.005 in./in. (mm/mm)/min shear strain \pm 25 %. Head speed may be calculated by the following equation:

$$n = ZL\sqrt{2} \quad (3)$$

where:

- n = crosshead speed, in./min (mm/min),
- L = length of side of shear area, in. (mm), and
- Z = shear strain rate, in./in.·min (mm/mm·min), normally taken as 0.005.

Measure the load and record to an accuracy of at least 1 %.

6.3.3 Determine the elapsed time from initiation of load application to maximum load and record to the nearest 1/2 min.

6.4 *Measurement of Deformation*—When modulus of rigidity is desired, strain measuring devices having a gage length not less than 1/8 nor more than 3/4 the length of a side of the shear area shall measure elongation of the vertical or tension diagonal on each side of the specimen to an accuracy of at least 2 %. The gage length shall be centered along the diagonal. Strain readings of the two gages shall be averaged for computation of elastic properties. Fig. 5 and Fig. 7 illustrate a suitable gaging method.