



Designation: D6839 – 13

Standard Test Method for Hydrocarbon Types, Oxygenated Compounds, and Benzene in Spark Ignition Engine Fuels by Gas Chromatography¹

This standard is issued under the fixed designation D6839; the number immediately following the designation indicates the year of original adoption or, in the case of revision, the year of last revision. A number in parentheses indicates the year of last reapproval. A superscript epsilon (ϵ) indicates an editorial change since the last revision or reapproval.

1. Scope

1.1 This test method covers the quantitative determination of saturates, olefins, aromatics, and oxygenates in spark-ignition engine fuels by multidimensional gas chromatography. Each hydrocarbon type can be reported either by carbon number (see [Note 1](#)) or as a total.

NOTE 1—There can be an overlap between the C₉ and C₁₀ aromatics; however, the total is accurate. Isopropyl benzene is resolved from the C₈ aromatics and is included with the other C₉ aromatics.

1.2 This test method is not intended to determine individual hydrocarbon components except benzene.

1.3 This test method is divided into two parts, Part A and Part B.

1.3.1 Part A is applicable to automotive motor gasoline for which precision (Table 9) has been obtained for total volume fraction of aromatics of up to 50 %; a total volume fraction of olefins from about 1.5 % up to 30 %; a volume fraction of oxygenates, from 0.8 % up to 15 %; a total mass fraction of oxygen from about 1.5 % to about 3.7 %; and a volume fraction of benzene of up to 2 %. Although this test method can be used to determine higher-olefin contents of up to 50 % volume fraction, the precision for olefins was tested only in the range from about 1.5 % volume fraction to about 30 % volume fraction. The method has also been tested for an ether content up to 22% volume fraction but no precision data has been determined.

1.3.1.1 This test method is specifically developed for the analysis of automotive motor gasoline that contains oxygenates, but it also applies to other hydrocarbon streams having similar boiling ranges, such as naphthas and reformates.

1.3.2 Part B describes the procedure for the analysis of oxygenated groups (ethanol, methanol, ethers, C₃ to C₅ alcohols) in ethanol fuels containing an ethanol volume fraction between 50 % and 85 % (17 to 29 % oxygen). The gasoline is diluted with an oxygenate-free component to lower the ethanol content to a value below 20 % before the analysis by GC. The

diluting solvent should not be considered in the integration, this makes it possible to report the results of the undiluted sample after normalization to 100 %

1.4 Oxygenates as specified in Test Method [D4815](#) have been verified not to interfere with hydrocarbons. Within the round robin sample set, the following oxygenates have been tested: MTBE, ethanol, ETBE, TAME, *iso*-propanol, isobutanol, *tert*-butanol and methanol. The derived precision data for methanol do not comply with the precision calculation as presented in this International Standard. Applicability of this test method has also been verified for the determination of *n*-propanol, acetone, and *di*-isopropyl ether (DIPE). However, no precision data have been determined for these compounds.

1.4.1 Other oxygenates can be determined and quantified using Test Method [D4815](#) or [D5599](#).

1.5 The method is harmonized with ISO 22854.

1.6 The values stated in SI units are to be regarded as standard. No other units of measurement are included in this standard.

1.7 *This standard does not purport to address all of the safety concerns, if any, associated with its use. It is the responsibility of the user of this standard to establish appropriate safety and health practices and determine the applicability of regulatory limitations prior to use.*

2. Referenced Documents

2.1 *ASTM Standards*:²

[D4307 Practice for Preparation of Liquid Blends for Use as Analytical Standards](#)

[D4815 Test Method for Determination of MTBE, ETBE, TAME, DIPE, tertiary-Amyl Alcohol and C₁ to C₄ Alcohols in Gasoline by Gas Chromatography](#)

[D5599 Test Method for Determination of Oxygenates in Gasoline by Gas Chromatography and Oxygen Selective Flame Ionization Detection](#)

¹ This test method is under the jurisdiction of ASTM Committee D02 on Petroleum Products, Liquid Fuels, and Lubricants and is the direct responsibility of Subcommittee D02.04.0L on Gas Chromatography Methods.

Current edition approved Oct. 1, 2013. Published November 2013. Originally approved in 2002. Last previous edition approved in 2007 as D6839 – 02 (2007). DOI: 10.1520/D6839-13.

² For referenced ASTM standards, visit the ASTM website, www.astm.org, or contact ASTM Customer Service at service@astm.org. For *Annual Book of ASTM Standards* volume information, refer to the standard's Document Summary page on the ASTM website.

2.2 Other Documents:

ISO 4259 Petroleum Products—Determination and Application of Precision Data in Relation to Methods of Test³

ISO 22854 Liquid Petroleum Products—Determination of Hydrocarbon Types and Oxygenates in Automotive-Motor Gasoline—Multidimensional Gas Chromatography Method³

3. Terminology

3.1 Definitions:

3.1.1 *oxygenate, n*—an oxygen-containing organic compound, which may be used as a fuel or fuel supplement, for example, various alcohols and ethers.

3.2 Definitions of Terms Specific to This Standard:

3.2.1 *hydrogenation, n*—the process of adding hydrogen to olefin molecules as a result of a catalytic reaction.

3.2.1.1 *Discussion*—Hydrogenation is accomplished when olefins in the sample contact platinum at a temperature of 180 °C in the presence of hydrogen. The olefins are converted into hydrogen saturated compounds of the same carbon number and structure. Monoolefins and diolefins convert to paraffins while cycloolefins and cycloienes convert to cycloparaffins.

3.2.2 *trap, n*—a device utilized to selectively retain specific portions (individual or groups of hydrocarbons or oxygenates) of the test sample and to release the retained components by changing the trap temperature.

3.3 Acronyms:

3.3.1 *ETBE*—ethyl-*tert*-butylether

3.3.2 *MTBE*—methyl-*tert*-butylether

3.3.3 *TAME*—*tert*-amyl-methylether

3.3.4 *DIPE*—*di*-isopropylether

4. Summary of Test Method

4.1 A representative sample is introduced into a computer controlled gas chromatographic system consisting of switching valves, columns, and an olefin hydrogenation catalyst, all operating at various temperatures. The valves are actuated at predetermined times to direct portions of the sample to appropriate columns and traps. As the analysis proceeds, the columns separate these sample portions sequentially into groups of different hydrocarbon types that elute to a flame ionization detector.

4.2 The mass concentration of each detected compound or hydrocarbon group is determined by the application of response factors to the areas of the detected peaks followed by normalization to 100 %. For samples containing methanol or other oxygenates that cannot be determined by this test method, the hydrocarbon results are normalized to 100 % minus the value of the oxygenates as determined by another test method such as Test Method D4815 or D5599.

4.3 The liquid volume concentration of each detected compound or hydrocarbon group is determined by application of

density factors to the calculated mass concentration of the detected peaks followed by normalization to 100 %.

5. Significance and Use

5.1 A knowledge of spark-ignition engine fuel composition is useful for regulatory compliance, process control, and quality assurance.

5.2 The quantitative determination of olefins and other hydrocarbon types in spark-ignition engine fuels is required to comply with government regulations.

5.3 This test method is not applicable to M85 fuels, which contain 85 % methanol.

6. Interferences

6.1 Some types of sulfur-containing compounds are irreversibly adsorbed in the olefin trap reducing its capacity to retain olefins. Sulfur containing compounds are also adsorbed in the alcohol and ether-alcohol-aromatic (EAA) traps. However, a variety of spark-ignition engine fuels have been analyzed without significant performance deterioration of these traps.

6.2 Commercial dyes used to distinguish between grades and types of spark-ignition engine fuels have been found not to interfere with this test method.

6.3 Commercial detergent additives utilized in spark-ignition engine fuels have been found not to interfere with this test method.

6.4 Dissolved water in spark-ignition engine fuels has been found not to interfere with this test method.

7. Apparatus

7.1 The complete system that was used to obtain the precision data shown in Section 14 is comprised of a computer controlled gas chromatograph, automated sample injector, and specific hardware modifications. These modifications include columns, traps, a hydrogenator, and valves, which are described in 7.7 and in Section 8. Fig. 1 illustrates a typical instrument configuration (see Note 4). Other configurations, components, or conditions may be utilized provided they are capable of achieving the required component separations and produce a precision that is equivalent to, or better than, that shown in the precision tables.

7.2 *Gas Chromatograph*, capable of temperature programmed operation at specified temperatures, equipped with a heated flash vaporization inlet, a flame ionization detector, necessary flow controllers, and computer control.

7.3 *Sample Introduction System*, using an automatic liquid injector, the injection volume shall be chosen in a way such that the capacity of the column is not exceeded and that the linearity of the detector is valid.

7.3.1 An injection volume of 0.1 µL has been found satisfactory.

7.4 *Gas Flow and Pressure Controllers*, with adequate precision to provide reproducible flow and pressure of the carrier gas to the chromatographic system, hydrogen for the

³ Available from American National Standards Institute (ANSI), 25 W. 43rd St., 4th Floor, New York, NY 10036, <http://www.ansi.org>.

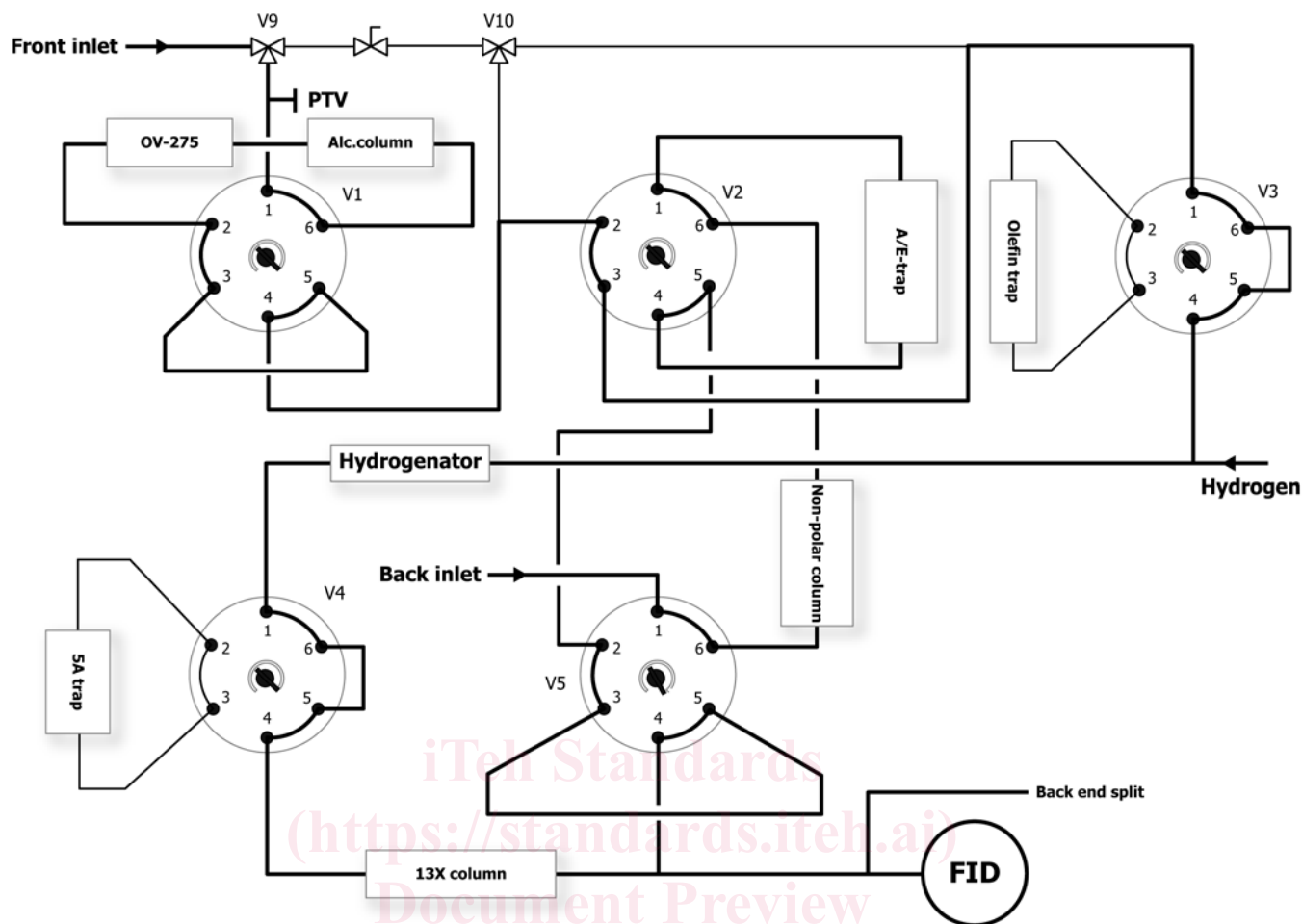

FIG. 1 Typical Instrument Configuration

hydrogenator, and hydrogen and air for the flame ionization detector. Control of air flow for cooling specific system components and for automated valve operation is also required.

7.5 Electronic Data Acquisition System, shall meet or exceed the following specifications (see Note 2):

7.5.1 Capacity for 150 peaks for each analysis.

7.5.2 Normalized area percent calculation with response factors.

7.5.2.1 Area summation of peaks that are split or of groups of components that elute at specific retention times.

7.5.3 Noise and spike rejection capability.

7.5.4 Sampling rate for fast (<0.5 s) peaks (>20 Hz to give 10 points across peak).

7.5.5 Peak width detection for narrow and broad peaks.

7.5.6 Perpendicular drop and tangent skimming, as required.

NOTE 2—Standard supplied software is typically satisfactory.

7.6 Temperature Controllers of System Components—The independent temperature control of numerous columns and traps, the hydrogenation catalyst, column switching valves, and sample lines is required. All of the system components that contact the sample shall be heated to a temperature that will prevent condensation of any sample component. Table 1 lists the system components and operating temperatures (see 7.6.1).

TABLE 1 Temperature Control Ranges of System Components

Component	Typical Operating Temperature Range, °C	Maximum Heating Time, min	Maximum Cooling Time, min
Alcohol trap	60–280	2	5
Polar column	130	isothermal	isothermal
Non-polar column	130	isothermal	isothermal
Olefin trap	120–280	1	5
Molsieve 13X column	90–430	Temperature programmed, ~10°/min	5
Ether-alcohol-aromatic (EAA) trap	70–280	1	5
Hydrogenation catalyst	180	isothermal	isothermal
Column switching valves	130	isothermal	isothermal
Sample lines	130	isothermal	isothermal

Some of the components require isothermal operation, some require rapid heating and cooling, while one requires reproducible temperature programming. The indicated temperatures are typical; however, the control systems utilized shall have the capability of operating at temperatures ± 20 °C of those indicated to accommodate specific systems. Temperature control may be by any means that will meet the requirements listed in Table 1.

7.6.1 The system components and temperatures listed in Table 1 and Section 8 are specific to the analyzer used to obtain

the precision data shown in Section 14. Other columns and traps that can adequately perform the required separations are also satisfactory but may require different temperatures.

7.7 *Valves, Column and Trap Switching*—Suitable automated switching valves are recommended. The valves shall be intended for gas chromatographic usage and meet the following requirements:

7.7.1 The valves must be capable of continuous operation at operating temperatures that will prevent sample condensation.

7.7.2 The valves shall be constructed of materials that are nonreactive with the sample under analysis conditions. Stainless steel, PFA, and Vespel⁴ are satisfactory.

7.7.3 The valves shall have a small internal volume but offer little restriction to carrier gas flow under analysis conditions.

7.7.4 New valves, tubing, catalyst, columns, traps, and other materials that contact the sample or gasses may require conditioning prior to operation in accordance with the manufacturer's recommendations.

7.8 *Gas Purifiers*, to remove moisture and oxygen from helium, moisture and hydrocarbons from hydrogen, and moisture and hydrocarbons from air.

8. Reagents and Materials

8.1 *Air*, compressed, <10 mg/kg each of total hydrocarbons and H₂O. (**Warning**—Compressed gas under high pressure that supports combustion.)

8.2 *Carrier Gas, Helium or Nitrogen*, 99.999 % pure, <0.1 mg/kg H₂O. (**Warning**—Compressed gas under high pressure.)

NOTE 3—The system's operating parameters such as column & trap temperatures, carrier gas flows and valve switching times are depending on the type of carrier gas used. The use of nitrogen as carrier gas may not be possible on all configurations. Contact the equipment manufacturer for specific information or instructions on the use of nitrogen.

8.3 *Hydrogen*, 99.999 % pure, <0.1 mg/kg H₂O. (**Warning**—Extremely flammable gas under high pressure.)

8.4 *Columns, Traps, and Hydrogenation Catalyst (System Components)*—Suitable columns and traps for reversible absorption of certain selected chemical groups must be used (an example is given in Table 1, see also 7.6.1). Each system component is independently temperature controlled as described in 7.6 and Table 1. Refer to Fig. 1 for the location of the components in the system (see Note 4). The following list of components contains guidelines that are to be used to judge suitability. The guidelines describe temperatures and times as used in a typical system. Alternatives can be used provided that the separation as described is obtained and the separation characteristics of the entire system are not limited.

NOTE 4—Fig. 1 shows an additional trap, Molsieve 5A, and rotary valve V4 that are not required for this test method. They are included in Fig. 1 because they were present in the instrumentation used to generate the precision data. They can be used for more detailed analyses outside the scope of this test method, where an iso-normal paraffin, iso-normal olefin determination is desired. There is no statistical data included in this test method relating to their use.

8.4.1 *Alcohol Trap*—Within a temperature range from 140 °C to 160 °C, this trap must elute benzene, toluene, all paraffins, olefins, naphthenes, and ethers within the first 2 min after sample injection while retaining C₈+ aromatics, all alcohols, and any other sample components.

8.4.1.1 At a temperature of 280 °C, all retained components from 8.4.1 shall elute within 2 min of when the trap is backflushed.

8.4.2 *Polar Column*—At a temperature of 130 °C, this column must retain all aromatic components in the sample longer than the time required to elute all non-aromatic components boiling below 185 °C, within the first 5 min after sample injection.

8.4.2.1 The column shall elute benzene, toluene, and all non-aromatic components with a boiling point below 215 °C within 10 min of the introduction of these compounds into the column.

8.4.2.2 This column shall elute all retained aromatic components from 8.4.2 within 10 min of when this column is backflushed.

8.4.3 *Non-Polar Column*—At a temperature of 130 °C, this column shall elute and separate aromatics by carbon number boiling below 200 °C. Higher boiling paraffins, naphthenes, and aromatics are backflushed.

8.4.4 *Olefin Trap*—Within a temperature range from 90 °C to 105 °C, this trap shall retain (trap) all olefins in the sample for at least 6.5 min and elute all non-olefinic components up to C₇ in less than 6.5 min after the sample is injected. Non-olefinic components C₉ and higher shall be retained during this time.

8.4.4.1 Within a temperature range from 140 °C to 150 °C this trap shall retain C₆ and higher olefins and elute all non-olefinic components in 3 min. Olefins up to C₆ may or may not elute in this time.

8.4.4.2 At a temperature of 280 °C, this trap shall quantitatively elute all retained olefins.

8.4.5 *Molsieve 13X Column*—This column shall separate paraffin and naphthene hydrocarbons by carbon number when temperature programmed from 90 °C to 430 °C at approximately 10°/min.

8.4.6 *Porapak Column*—At a temperature from 130 °C to 140 °C, this column shall separate individual oxygenates, benzene, and toluene.

NOTE 5—The use of a Porapak column is not required in all configurations. For more information on a specific system, contact the equipment manufacturer.

8.4.7 *Ether-Alcohol-Aromatic (EAA) Trap*—Within a temperature range from 105 °C to 130 °C, this trap shall retain all of the ethers in the sample and elute all non-aromatic hydrocarbons boiling below 175 °C within the first 6 min after sample injection.

8.4.7.1 At a temperature of 280 °C, this trap shall elute all retained components.

8.4.8 *Hydrogenation Catalyst*, platinum. At a temperature of 180 °C and an auxiliary hydrogen flow of 14 ± 2 mL/min, this catalyst shall quantitatively hydrogenate all olefins to paraffinic compounds of the same structure without cracking.

⁴ PFA and Vespel are trademarks of E. I. DuPont de Nemours and Co.

TABLE 2 System Validation Test Mixture

Component	Approximate Concentration Mass, %	Warning
Cyclopentane	1.1	A
Pentane	1.1	A
Cyclohexane	2.1	A
2,3-Dimethylbutane	2.1	A
Hexane	2.1	A
1-Hexene	1.5	A
Methylcyclohexane	4.0	A
4-Methyl-1-hexene	1.6	A
Heptane	3.5	B
1- cis-2-Dimethylcyclohexane	5.0	A
2,2,4-Trimethylpentane	5.0	B
Octane	5.0	B
1- cis-2- cis-4-Trimethylcyclohexane	4.0	B
Nonane	4.5	B
Decane	4.5	B
Undecane	3.5	B
Dodecane	3.5	B
Benzene	2.2	B
Methylbenzene (Toluene)	2.2	B
trans-Decahydronaphthalene (Decalin)	4.0	B
Tetradecane	4.5	B
Ethylbenzene	4.5	A
1,2-Dimethylbenzene (o-Xylene)	4.0	A
Propylbenzene	5.0	A
1,2,4-Trimethylbenzene	4.5	A
1,2,3-Trimethylbenzene	5.0	A
1,2,4,5-Tetramethylbenzene	5.0	B
Pentamethylbenzene	5.0	C
Group Totals		
Paraffins	34.8	
Olefins	3.1	
Naphthenes	20.2 (including Decalin)	
Aromatics	41.9	
Oxygenates	0.0	
TOTAL	100.0	

^A (Warning)—Extremely flammable. Harmful if inhaled.)

^B (Warning)—Flammable. Harmful if inhaled.)

^C (Warning)—Harmful if inhaled.)

8.5 *Test Mixture*—A quantitative synthetic mixture of pure hydrocarbons is required to verify that all instrument components, temperatures, and cut times are satisfactory to produce accurate analyses and to aid in making operating adjustments as columns and traps age. The mixture may be purchased or prepared according to Practice **D4307**. Each component used in the test mixture preparations shall have a minimum purity of 99 %. The actual concentration levels are not critical but shall be accurately known.

8.5.1 *System Validation Test Mixture*, used to monitor and make adjustments to the total operation of the system. The composition and approximate component concentrations are shown in **Table 2**.

8.6 *Quality Control Sample*, used to routinely monitor the operation of the chromatographic system and verify that reported concentrations are within the precision of the test method. Depending on the range and composition of the samples to be analyzed, more than one quality control sample may be necessary. Any sample that is similar in composition to samples typically analyzed may be designated as the quality control (QC) sample. The QC sample shall be of sufficient volume to provide an ample supply for the intended period of

TABLE 3 Typical Gas Flow Rates

Gas	Flow Rate
He (Flow A)	22 ± 2 mL/min
He (Flow B)	12 ± 1 mL/min
H ₂ (hydrogenator)	14 ± 2 mL/min
H ₂ (FID)	30–35 mL/min
Air (FID)	400–450 mL/min

use and it shall be homogeneous and stable under the anticipated storage conditions.

8.6.1 The quality control sample should have similar composition and hydrocarbon distribution as the sample with highest olefin concentration routinely analyzed.

8.6.2 The quality control sample should contain oxygenates as analyzed in routine samples. Separate standards could be used for different oxygenates.

8.6.2.1 In the event that samples containing TAME or ethanol need to be analyzed, it is best to use separate standards since optimal separation of these components requires different alcohol trap temperature conditions.

8.7 Diluting solvent, used in Part B, should not be interfering with any other component in gasoline being analyzed. Dodecane (C₁₂H₂₆) or tridecane (C₁₃H₂₈) are recommended solvents.

9. Preparation of Apparatus

9.1 Assemble the analyzer system (gas chromatograph with independent temperature controlled components) as shown in **Fig. 1** or with a similar flow system. If using a commercial system, install and place the system in service in accordance with the manufacturer's instructions.

9.2 Impurities in the carrier gas, hydrogen, or air will have a detrimental effect on the performance of the columns and traps. Therefore, it is important to install efficient gas purifiers in the gas lines as close to the system as possible and to use good quality gases. The carrier gas and hydrogen gas connection lines shall be made of metal. Check that all gas connections, both exterior and interior to the system, are leak tight.

9.3 The gas flow rates on commercial instruments are normally set prior to shipment and normally require little adjustment. Optimize flow rates on other systems to achieve the required separations. Typical flow rates for the commercial instrument used in the precision study are given in **Table 3**; however, the flows can differ somewhat from system to system.

9.3.1 Set air flow rates for column/trap cooling and for operation of air actuated valves, if required.

9.4 *System Conditioning*—When gas connections have been disconnected or the flow turned off, as on initial start up, condition the system by permitting carrier gas to flow through the system for at least 30 min while the system is at ambient temperature. After the system has been conditioned, analyze the system validation test mixture, as described in Section **11**, discarding the results.

10. Standardization

10.1 The elution of components from the columns and traps depends on the applied temperatures. The switching valves

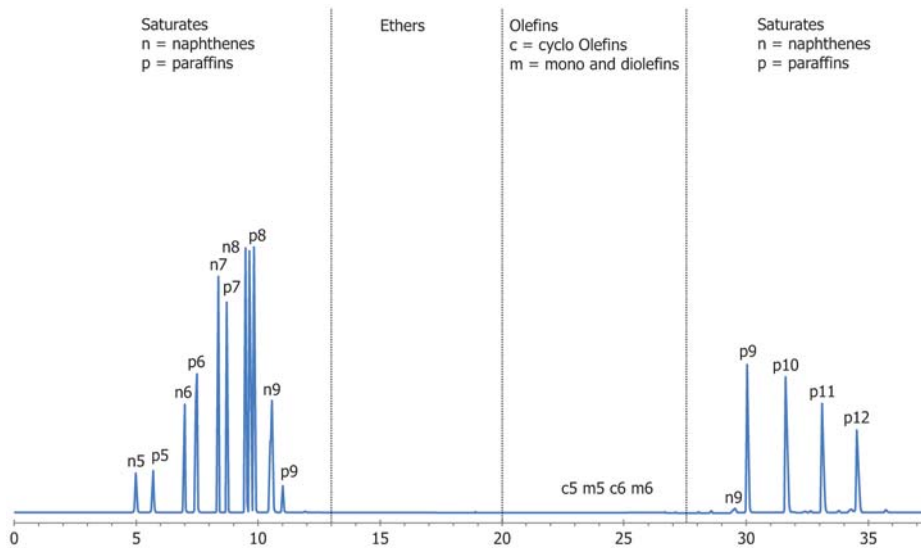

FIG. 2 Example of a Gravimetric Test Blend Analysis 1/2

also need to be actuated at exact times to make separations of compounds into groups, for example, to retain specific compounds in a column or trap while permitting other compounds to elute. Therefore, the separation temperatures of the columns/traps and the valve timing are critical for correct operation of the system. These parameters need to be verified on the start up of a new system (see Note 6) for correctness. They also require evaluation and adjustment as necessary on a regular basis to correct for changes to columns and traps as a result of aging. To do this, the analyst shall analyze several test mixtures and make changes, as required, based on an evaluation of the resulting chromatograms and test reports.

10.2 Using the procedure outlined in Section 11, analyze the system validation test mixture. Carefully examine the chromatogram obtained to verify that all the individual components of the test mixture are correctly identified as compared to the reference chromatogram (Figs. 2 and 3). Test results for group totals shall agree with the known composition (see Table 2) within ± 0.5 mass %. Test results for groups by hydrocarbon number shall agree with the known composition (see Table 2) within 0.2 mass %. If these specifications are met, proceed to the analysis of the quality control samples (see 10.3).

10.2.1 If the specifications in 10.2 are not met, adjust the temperature of specific columns and traps or valve timing according to the manufacturer's guidelines and reanalyze the system validation test mixture until they are met.

10.3 Analyze quality control samples; see 8.6. Verify that results are consistent with those previously obtained and that the separation of olefins and saturates is correct.

10.3.1 Breakthrough of olefins to the saturate fraction is indicated by a rising baseline under the C_5 to C_6 saturates region or additional peaks between the C_4 and C_6 peaks. If breakthrough is observed, optimize the olefin trap temperature or, if necessary, replace the trap.

10.3.2 If the fraction containing C_4 to C_6 olefins and C_7 to C_{10} saturates shows peaks in the C_7 region, optimize the olefin trap temperatures or, if necessary, replace the trap.

10.3.3 Loadability limits for olefins are listed in 1.3. These limits depend on the condition of the olefin trap, and an aged trap may not have this capacity. Use the quality control sample (see 8.6) to verify olefin capacity.

10.3.4 Check that the correct qualitative and quantitative analysis of oxygenates are achieved for the quality control sample. If qualitative or quantitative specifications are not met, optimize the alcohol trap temperature and ether-alcohol-aromatic trap temperature or replace the columns as necessary.

10.4 Reanalyze the system validation test mixture whenever the quality control sample does not conform to expected results (see 10.3) and make adjustments as necessary (see 10.2).

Part A—PROCEDURE APPLICABLE TO AUTOMOTIVE MOTOR GASOLINE AND HYDROCARBON STREAMS WITH SIMILAR BOILING RANGES