



Designation: **F2012–12 F2012 – 13**

# Standard Consumer Safety Performance Specification for Stationary Activity Centers<sup>1</sup>

This standard is issued under the fixed designation F2012; the number immediately following the designation indicates the year of original adoption or, in the case of revision, the year of last revision. A number in parentheses indicates the year of last reapproval. A superscript epsilon ( $\epsilon$ ) indicates an editorial change since the last revision or reapproval.

## INTRODUCTION

This consumer safety performance specification is intended to mitigate potential safety hazards associated with a child's use of a stationary activity center and thereby minimize the risk of injury or death. The specific hazards addressed by this specification are seat strength to support the occupant, product tip over, openings for finger entrapment and small parts.

### 1. Scope

1.1 This consumer safety performance specification covers performance requirements, test methods and marking requirements to promote safe use of a stationary activity center by an occupant.

1.2 This consumer safety performance specification is intended to minimize the risk of incidents to an occupant resulting from normal use and reasonably foreseeable misuse or abuse of a stationary activity center.

1.3 No stationary activity center produced after the approval date of this consumer safety performance specification shall, either by label or other means, indicate compliance with this specification unless it conforms to all requirements contained herein.

1.4 This consumer safety performance specification is not intended to address incidents and injuries resulting from the interaction of other persons with the child occupant in the stationary activity center or the incidents resulting from abuse and misuse by children able to walk.

1.5 The values stated in inch-pound units are to be regarded as standard. The values given in parentheses are mathematical conversions to SI units that are provided for information only and are not considered standard.

1.6 The following precautionary caveat pertains only to the test methods portion, Section 7, of this consumer safety performance specification: *This standard does not purport to address all of the safety concerns, if any, associated with its use. It is the responsibility of the user of this standard to establish appropriate safety and health practices and determine the applicability of regulatory limitations prior to use.*

### 2. Referenced Documents

2.1 *ASTM Standards:*<sup>2</sup>

[D3359 Test Methods for Measuring Adhesion by Tape Test](#)

[F963 Consumer Safety Specification for Toy Safety](#)

2.2 *Federal Regulations:*<sup>3</sup>

[16 CFR 1303 Ban of Lead-Containing Paint and Certain Consumer Products Bearing Lead-Containing Paint](#)

[16 CFR 1500 Hazardous Substances Act Regulations including sections:](#)

[1500.18\(a\)\(6\) Banned Toys and Other Banned Articles Intended for Use by Children](#)

[1500.48 Technical Requirements for Determining a Sharp Point in Toys or Other Articles Intended for Use by Children Under Eight Years of Age](#)

[1500.49 Technical Requirements for Determining a Sharp Metal or Glass Edge in Toys or Other Articles Intended for Use by Children Under Eight Years of Age](#)

<sup>1</sup> This consumer safety performance specification is under the jurisdiction of ASTM Committee F15 on Consumer Products and is the direct responsibility of Subcommittee F15.17 on Carriages, Strollers, Walkers and Stationary Activity Centers.

Current edition approved June 1, 2012; Nov. 1, 2013. Published June 2012; November 2013. Originally approved in 2000. Last previous edition approved in 2011 as F2012–11; F2012–12. DOI: 10.1520/F2012-12-10.1520/F2012-13.

<sup>2</sup> For referenced ASTM standards, visit the ASTM website, [www.astm.org](http://www.astm.org), or contact ASTM Customer Service at [service@astm.org](mailto:service@astm.org). For *Annual Book of ASTM Standards* volume information, refer to the standard's Document Summary page on the ASTM website.

<sup>3</sup> Available from Superintendent of Documents, US Government Printing Office, Washington, DC 20402.

1500.50-52 Test Methods for Simulating Use and Abuse of Toys and Other Articles Intended for Use by Children

15.00.86(a)(4) Exemptions from Classification as a Banned Article for Use by Children

16 CFR 1501 Method for Identifying Toys and Other Articles Intended for Use by Children Under Three Years of Age Which Present Choking, Aspiration or Ingestion Hazards Because of Small Parts

2.3 Other Standards:

ASME/ANSI B16.9 Factory-Made Wrought Steel Butt Welding Fittings<sup>4</sup>

2.4 Other References:

CAMI Infant Dummy, Mark II (see Fig. 1)<sup>5</sup>

### 3. Terminology

3.1 Definitions of Terms Specific to This Standard:

3.1.1 *conspicuous, adj*—a label that is visible, when the activity center is in a manufacturer’s recommended use position, to a person standing near the activity center at any one position around the activity center but not necessarily visible from all positions.

3.1.2 *dynamic load, n*—application of an impulsive force through free fall of a weight.

3.1.3 *manufacturer’s recommended use position(s), n*—any position that is presented as a normal, allowable or acceptable configuration for the use of the product by the manufacturer in any descriptive or instructional literature. This specifically excludes positions that the manufacturer shows in a like manner in its literature to be unacceptable, unsafe or not recommended.

3.1.4 *non-paper label, n*—any label material (such as plastic or metal) which either will not tear without the aid of tools or tears leaving a sharply defined edge.

3.1.5 *occupant, n*—that individual who is in a product that is set up in one of the manufacturer’s recommended use positions.

3.1.6 *open base stationary activity center, n*—a stationary activity center that allows the occupant’s feet to contact the floor.

3.1.7 *paper label, n*—any label material which tears without the aid of tools and leaves a fibrous edge.

3.1.8 *static load, n*—a vertically downward force applied by a calibrated force gauge or by dead weights.

3.1.9 *stationary activity center, n*—a freestanding product intended to remain stationary that enables a sitting or standing occupant whose torso is completely surrounded by the product to walk, rock, play, spin or bounce, or all of these, within a limited range of motion.

### 4. Calibration and Standardization

4.1 All testing shall be conducted on a concrete floor that may be covered with 1/8 in. (3 mm) thick vinyl flooring, unless test instructs differently.

ASTM F2012-13

<sup>4</sup> Available from American Society of Mechanical Engineers (ASME), ASME International Headquarters, Three Park Ave., New York, NY 10016-5990, <http://www.asme.org>.

<sup>5</sup> Department of Transportation Memorandum Report AAC-119-74-14, Revision II, Drawing No. SA-1001 by Richard Chandler, July 2, 1974. Federal Aviation Administration, Civil Aeromedical Institute, Protection and Survival Laboratory, Aeronautical Center, Oklahoma City, OK 73125.



FIG. 1 CAMI Infant Dummy—Mark II

- 4.2 The product shall be completely assembled, unless otherwise noted, in accordance with the manufacturer's instructions.
- 4.3 No testing shall be conducted within 48 h of manufacturing.
- 4.4 The product to be tested shall be in a room with an ambient temperature of  $73 \pm 9^{\circ}\text{F}$  ( $23 \pm 5^{\circ}\text{C}$ ) for at least 1 h prior to testing. Testing shall then be conducted within this temperature range.
- 4.5 All testing required by this specification shall be conducted on the same unit.

## 5. General Requirements

5.1 *Hazardous Sharp Edges or Points*—There shall be no hazardous sharp edges or points as defined by 16 CFR 1500.48 and 16 CFR 1500.49 before and after testing to this consumer safety specification.

5.2 *Small Parts*—There shall be no small parts as defined by 16 CFR 1501 before testing or liberated as a result of testing to this specification

5.3 *Wood Parts*—Prior to testing, any exposed wood parts shall be smooth and free of splinters.

5.4 *Latching or Locking Mechanisms*—Any product that folds shall have a latching or locking device or other provision in the design that will prevent the unit from unintentionally folding when properly placed in the manufacturer's recommended use position. The unit shall remain in its manufacturer's recommended use position during and upon completion of the test in accordance with 7.2. If a unit is designed with a latching or locking device, that device shall remain engaged and operative after testing.

5.5 *Openings*—Holes or slots that extend entirely through a wall section of any rigid material less than 0.375 in. (9.53 mm) thick and admit a 0.210-in. (5.33-mm) diameter rod shall also admit a 0.375-in. (9.53-mm) diameter rod. Holes or slots that are between 0.210 in. (5.33 mm) and 0.375 in. (9.53 mm) and have a wall thickness less than 0.375 in. (9.53 mm), but are limited in depth to 0.375 in. (9.53 mm) maximum by another rigid surface shall be permissible (see Fig. 2). The product shall be evaluated in all manufacturer's recommended use positions.

5.6 *Scissoring, Shearing, Pinching*—A product, when in a manufacturer's recommended use position, shall be designed and constructed so as to prevent injury to the occupant from any scissoring, shearing or pinching when members or components rotate about a common axis or fastening point, slide, pivot, fold or otherwise move relative to one another. Scissoring, shearing or pinching that may cause injury shall not be permissible when the edges of the rigid parts admit a probe greater than 0.210 in. (5.33 mm) and less than 0.375 in. (9.53 mm) diameter at any accessible point throughout the range of motion of such parts.

5.7 *Exposed Coil Springs*—Any exposed coil spring which is accessible to the occupant, having or capable of generating a space between coils of 0.210 in. (5.33 mm) or greater during static load testing in accordance with 7.1.2 shall be covered or otherwise designed to prevent injury from entrapment.

5.8 *Labeling:*

5.8.1 Warning labels (whether paper or non-paper) shall be permanent when tested in accordance with 7.5.1 – 7.5.3.

5.8.2 Warning statements applied directly onto the surface of the product by hot stamping, heat transfer, printing, wood burning, etc. shall be permanent when tested in accordance with 7.5.4.

5.8.3 Nonpaper labels shall not liberate small parts when tested in accordance with 7.5.5.

5.9 *Toys*—Toy accessories attached to, removable from, or sold with a stationary activity center, as well as their means of attachment, must meet applicable requirements of Consumer Safety Specification F963.

5.10 *Protective Components*—If a child can grasp protective components between the thumb and forefinger, or teeth, such as caps, sleeves, or plugs used for protection from sharp edges, points, or entrapment of fingers or toes, or if there is at least a 0.040 in. (1.00 mm) gap between the protective component and its adjacent parent component, such protective components shall not be removed when tested in accordance with 7.4.

## 6. Performance Requirements

NOTE 1—The forces which are to be applied to the sample in the tests described in Section 7 of this standard are readily applied by means of a calibrated force gauge, or in the case of static load and dynamic load tests, by dead weights.

6.1 *Structural Integrity*—All tests that cover static and dynamic loading, and occupant retention, are to be performed on the same product, sequentially and without refurbishing or repositioning of adjustment, if any. At test conclusion, there shall be no failure of seams, breakage of materials or changes of adjustments that could cause the product not to fully support the child or create a hazardous condition as defined in Section 5. Maximum slippage of adjustable features, if any, is 1 in. (25 mm).

6.1.1 *Dynamic Load*—Test in accordance with 7.1.1.

6.1.2 *Static Load*—Test in accordance with 7.1.2.

6.2 *Leg Openings*—The seat of the stationary activity center shall be designed so that the leg openings will not permit the passage of the test probe shown in Fig. 3 when tested in accordance with 7.1.3.

6.3 *Stability:*

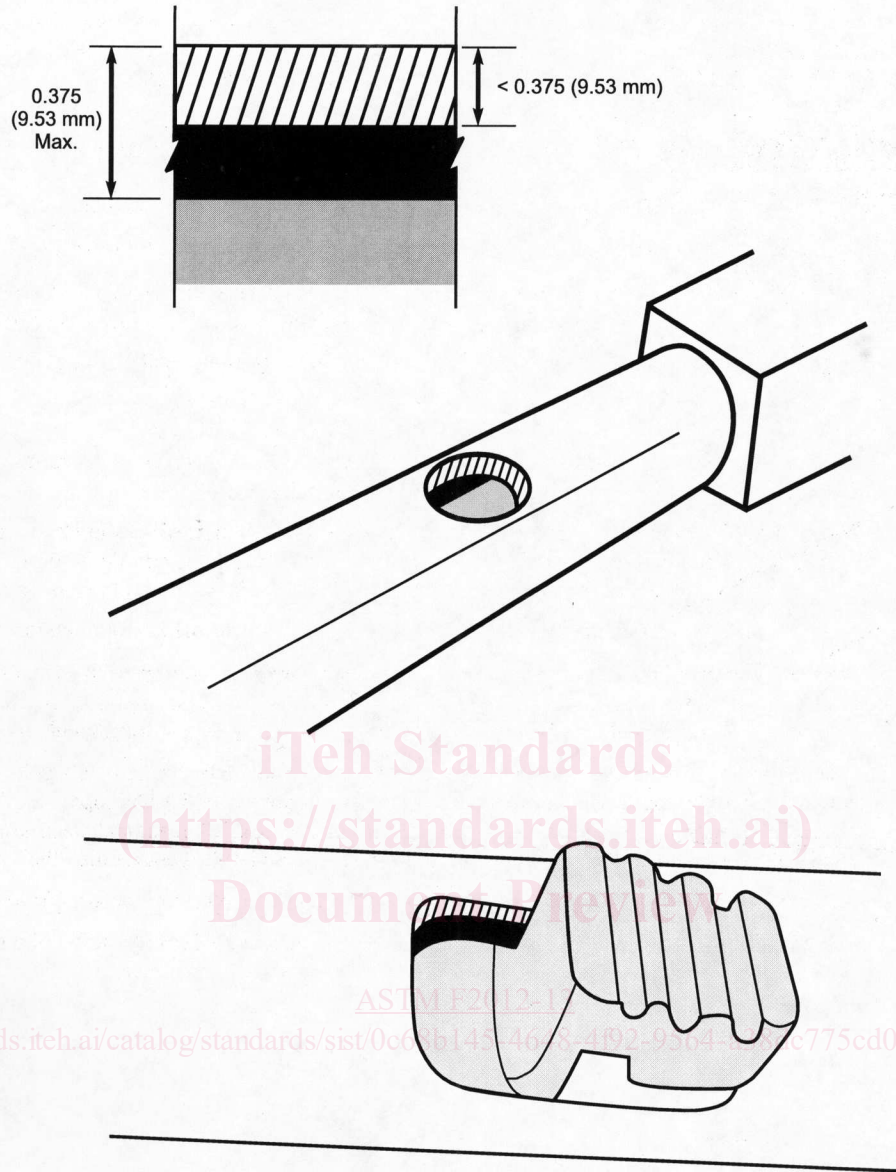

FIG. 2 Opening Example

6.3.1 *Tip-Over*—A stationary activity center shall not tip over, when tested in accordance with 7.3.1.

6.3.2 *Seat Tilt*—For stationary activity centers with freely suspended spring (or equivalent) supported seats, the seat shall not tip more than 25° from the horizontal when tested in accordance with 7.3.2. This requirement does not apply to stationary activity centers where the direction and travel of the seat is controlled by the frame of the product.

NOTE 2—Apply either 6.3.1 or 6.3.2, not both, to product as applicable.

6.4 *Motion Resistance—Resistance for Open Base Stationary Activity Centers:*

6.4.1 All closed base stationary activity centers are exempt from the requirement in 6.4.

6.4.2 *Stationary Activity Center that Does Not Rotate Around a Central Stationary Post*—The stationary activity center shall not move more than 1.0 in. (25.4 mm) in the direction of the applied force from its original position when tested in accordance with 7.6.1.

6.4.3 *Stationary Activity Center that Rotates Around Central Stationary Post:*

6.4.3.1 The stationary post shall not move more than 1.0 in. (25.4 mm) in the direction of the applied force when tested in accordance with 7.6.2.3.

6.4.3.2 The stationary post shall not move more than 1.0 in. (25.4 mm) in any direction when tested in accordance with 7.6.2.4.

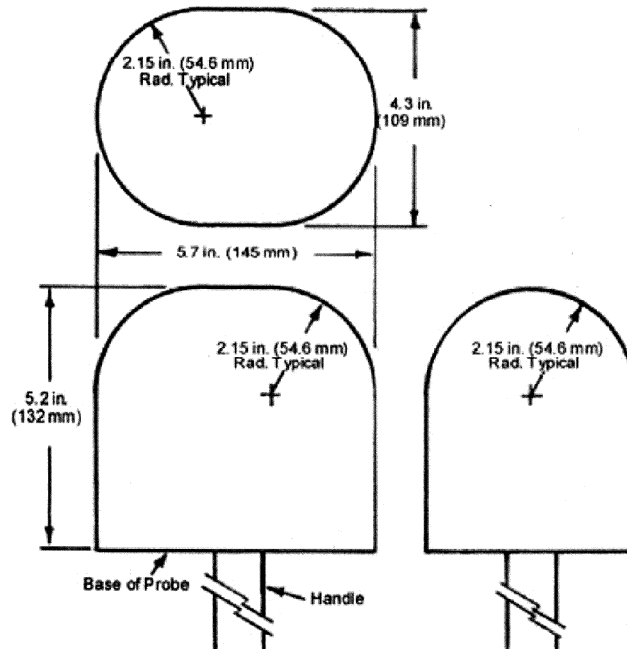

NOTE 1—Dimensions are based on a 5th percentile 6-month-old child. Gauge may be modified to facilitate testing to allow for pulling of the gauge.

FIG. 3 Small Head Test Probe

## 7. Test Methods

NOTE 3—Except for the Structural Integrity tests in 7.1, which shall be performed first, the tests can be performed in any sequence.

### 7.1 Structural Integrity:

#### 7.1.1 Dynamic Load:

7.1.1.1 Position the stationary activity center in the manufacturer's recommended use position. If adjustable, adjust to the highest and most upright position.

7.1.1.2 Affix to the stationary activity center seat a 6-by-6 in. (150-by-150 mm) wood block  $\frac{3}{4}$  in. (19 mm) thick. If the unit has a hammock type seat, use a standard 6 in. (150 mm) weld cap, convex surface down, as identified in Fig. 4, attached to the bottom of the test weight.

7.1.1.3 Drop a test weight of 33 lb (15 kg), with the mass of the weld cap shown in Fig. 4 included, onto the seat at least a distance of 1 in. (25 mm) one hundred times.

7.1.1.4 When testing a spring supported adjustable stationary activity center, test with the product in the highest adjustment position and support the frame so that the dropping of the 33 lb (15 kg) weight does not cause the seat to bottom out.

#### 7.1.2 Static Load:

7.1.2.1 Position the stationary activity center as in 7.1.1.1.

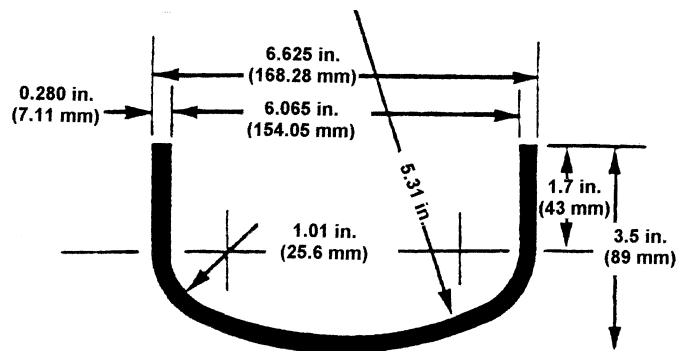

NOTE 1—Caps furnished to ANSI standards unless otherwise specified. Welding caps are formed from steel plate and are ellipsoidal in shape. The minor axis being equal to one half the major axis radii "R" and "r" closely approximate the actual semi-ellipsoidal shape. All dimensions in inches and are in accordance with ASME/ANSI B16.9.

FIG. 4 Nominal 6-in. Weld Cap Weight (Approximately) 6.4 lb (2.90 kg)

7.1.2.2 Center a weight of 90 lb (41 kg) for a period of 1 min on a 6-by-6 in. (150-by-150 mm) wood block  $\frac{3}{4}$  in. (19 mm) thick affixed to the stationary activity center seat. If the unit has a hammock type seat, use a standard 6 in. (150 mm) weld cap, convex surface down, as identified in Fig. 4 instead of the specified wood block. Make weight allowance for the weld cap. If the natural action of a bouncer type stationary activity center allows the seat to contact the floor and will not allow the full application of the 90 lb (41 kg) static load, then restrict the bouncer mechanism by any means possible so that the full static load can be applied to the seat or section of the stationary activity center occupied by the child. Inspect the action of all supporting, locking and adjusting components to assure that they do not create a hazardous condition as defined in Section 5.

7.1.2.3 Position the stationary activity center in the manufacturer's recommended use position. If adjustable, adjust to the lowest position.

7.1.2.4 Center a weight of 50 lb (22.7 kg) for a period of 1 min on a 6-by-6 in. (150-by-150 mm) wood block  $\frac{3}{4}$  in. (19 mm) thick affixed to the stationary activity center seat. If the unit has a hammock type seat, use a standard 6 in. (150 mm) weld cap, convex surface down, as identified in Fig. 4 instead of the specified wood block. Make weight allowance for the weld cap. In this test, DO NOT restrict the bouncer mechanism from folding or bottoming out. Inspect the action of all supporting, locking and adjusting components to assure that they do not create a hazardous condition as defined in Section 5.

### 7.1.3 Leg Openings Test:

7.1.3.1 If the seat is adjustable, adjust the seat to obtain the largest leg opening.

7.1.3.2 Rotate the test probe shown in Fig. 3 to the orientation most likely to fail and gradually apply a force of 25-lbf (111 N). Apply the force perpendicular to the base of the probe within a period of 5 s and maintain it for an additional 10 s.

### 7.2 Latching or Locking Mechanism Activation:

7.2.1 *Stationary Activity Centers with Single Action Release Mechanism*—With the product in each manufacturer's recommended use position, gradually apply a 10 lbf (45 N) force to the latching or locking mechanism in the direction tending to release it.

7.2.2 *Stationary Activity Centers with Double Action Release Mechanism*—Each double action locking/latching mechanism shall require two distinct and separate actions for release of the mechanism.

### 7.3 Stability:

#### 7.3.1 Tip Over:

7.3.1.1 Position the stationary activity center in the most disadvantageous manufacturer's recommended use position. If adjustable, adjust to the highest and most upright position.

7.3.1.2 Clamp a 1-by-1 in. (25-by-25 mm) rigid aluminum angle to the uppermost front and rear horizontal frame members of the stationary activity center. The length of the aluminum angle should be such that it extends forward at least 12 in. (300 mm) beyond the front edge of the occupant seating area as shown in Fig. 5.

7.3.1.3 Place a weight of 17 lb (7.7 kg) on the aluminum angle at a distance "X" which is 1 in. (25 mm) less than one-half the difference between 32 in. (810 mm) or the maximum height of the user (whichever is greater) as defined in 9.2.3 and the height of the stationary activity center. The height of the stationary activity center is the vertical measurement from the top edge of the tray adjacent to the occupant seating area to the point on the occupant's support surface directly below the center of the seating area as shown in Fig. 5.

The formula to determine "X" in. =  $((32 \text{ in. or max height of user} - \text{height of tray adjacent to occupant seating area})/2) - 1$

7.3.1.4 Repeat 7.3.1.1, 7.3.1.2 and 7.3.1.3, except position the aluminum angle in both sideward directions perpendicular to the position tested in 7.3.1.2. Be sure the aluminum angle extends at least 12 in. (300 mm) beyond the inside edge of the tray or horizontal frame member.

7.3.1.5 Repeat 7.3.1.1, 7.3.1.2 and 7.3.1.3, except position the aluminum angle in the rearward direction tested in 7.3.1.2. Be sure the aluminum angle extends at least 12 in. (300 mm) beyond the inside of the tray or horizontal frame member.

#### 7.3.2 Seat Tilt:

7.3.2.1 Position the stationary activity center on a horizontal surface in the manufacturers' recommended use position. If adjustable, adjust to the highest and most upright position.

7.3.2.2 Clamp a 1-by-1 in. (25-by-25 mm) rigid aluminum angle to the top of the seat frame forward of the occupant seating area such that the angle is level with the horizontal. The length of the aluminum angle should be such that it extends forward at least 12 in. (300 mm) beyond the front edge of the occupant seating area as shown in Fig. 5. If any soft goods or toys interfere with the placement of the angle they may be removed.

7.3.2.3 For activity centers with more than one seat position (for example, rotating seats), position the seat in the most onerous orientation for seat tilt in the direction forward of the occupant seating area.

7.3.2.4 Using a dead weight, apply a vertical load of 17 lb (7.7 kg) on the aluminum angle at a distance of 3.5 in. (89 mm) from the inside front edge of the occupant seating area. Apply the load within 5 s and maintain for 10 s.

7.3.2.5 Repeat 7.3.2.1 and 7.3.2.2, 7.3.2.3 and 7.3.2.4 for three additional positions—to the left, right, and rear of the occupant seating area (at 90° intervals from the most onerous position). For these positions, the 17 lb (7.7 kg) weight shall be placed on the aluminum angle at a distance of 2.0 in. (51 mm) from the respective inside edges of the occupant seating area.

### 7.4 Removal of Protective Components: