



Standard Test Method for Tensile Stress-Strain of Carbon and Graphite¹

This standard is issued under the fixed designation C749; the number immediately following the designation indicates the year of original adoption or, in the case of revision, the year of last revision. A number in parentheses indicates the year of last reapproval. A superscript epsilon (ϵ) indicates an editorial change since the last revision or reapproval.

^{ε1} NOTE—Updated units scope statement and Table 1 editorially in May 2010.

1. Scope—Scope*

1.1 This test method covers the testing of carbon and graphite in tension to obtain the tensile stress-strain behavior, to failure, from which the ultimate strength, the strain to failure, and the elastic moduli may be calculated as may be required for engineering applications. **Table 2** lists suggested sizes of specimens that can be used in the tests.

NOTE 1—The results of about 400 tests, on file at ASTM as a research report, show the ranges of materials that have been tested, the ranges of specimen configurations, and the agreement between the testers. See Section 11.

NOTE 2—For safety considerations, it is recommended that the chains be surrounded by suitable members so that at failure all parts of the load train behave predictably and do not constitute a hazard for the operator.

1.2 The values stated in inch-pound units are to be regarded as standard. The values given in parentheses are mathematical conversions to SI units that are provided for information only and are not considered standard. Conversions are not provided in the tables and figures.

1.3 *This standard does not purport to address all of the safety concerns, if any, associated with its use. It is the responsibility of the user of this standard to establish appropriate safety and health practices and determine the applicability of regulatory limitations prior to use.*

2. Referenced Documents

2.1 *ASTM Standards:*²

C565 Test Methods for Tension Testing of Carbon and Graphite Mechanical Materials

C709 Terminology Relating to Manufactured Carbon and Graphite

E4 Practices for Force Verification of Testing Machines

E6 Terminology Relating to Methods of Mechanical Testing

E177 Practice for Use of the Terms Precision and Bias in ASTM Test Methods

E691 Practice for Conducting an Interlaboratory Study to Determine the Precision of a Test Method

3. Terminology

3.1 *Definitions*—The terms as related to tension testing as given in Terminology **E6** shall be considered as applying to the terms used in this test method. See also Terminology **C709**.

4. Summary of Test Method

4.1 A tensile specimen (**Fig. 1**) is placed within a load train assembly made up of precision chains and other machined parts (**Fig. 2**). A load is applied to the specimen provided with means of measuring strain until it is caused to fracture. This test yields the tensile strength, elastic constants, and strain to failure of carbons and graphites.

5. Significance and Use

5.1 The round robin testing on which the precision and bias for this test method have been determined employed a range of graphites (see **Table 2**) whose grain sizes were of the order of 1 mil to ¼ in. (0.0254 to 6.4 mm) and larger. This wide range of

¹ This test method is under the jurisdiction of ASTM Committee **D02** on Petroleum Products—Products, Liquid Fuels, and Lubricants and is the direct responsibility of Subcommittee **D02.F0** on Manufactured Carbon and Graphite Products.

Current edition approved May 1, 2010/Oct. 1, 2013. Published May 2010/November 2013. Originally approved in 1973. Last previous edition approved in 2008/2010 as C749 – 08–08 (2010)^{ε1}. DOI: 10.1520/C0749-08R10E01-10.1520/C0749-13.

² For referenced ASTM standards, visit the ASTM website, www.astm.org, or contact ASTM Customer Service at service@astm.org. For *Annual Book of ASTM Standards* volume information, refer to the standard's Document Summary page on the ASTM website.

*A Summary of Changes section appears at the end of this standard

TABLE 1 List of Materials Shown in Fig. 2

Assembly	Item	Quantity	Name, Description, Material
1A ½ in. ^A grips ^{B,C}	101	2	Crosshead attachment yoke—1 dia x 4 long—416 or 440 S.S.
	102	2	Chain— $\frac{3}{16}$ dia, 700 pound tensile limit, 10 links long—Carbon Steel
	103	4	Chain journal— $\frac{9}{16}$ dia x ½ long—416 or 440 S.S. ^D
	104	4	Pin— $\frac{3}{16}$ dia x 1—Std Dowel
	105	2	Grip attachment yoke—1 dia x $2\frac{5}{8}$ long—416 or 440 S.S. ^D
	106	2	Pin—¼ shank dia with ½ dia x $\frac{3}{4}$ long knurled head, total length $2\frac{1}{2}$, taper first half inch at 10°—416 or 440 S.S. ^D
	107	2	Grip sleeve—1½ dia x $2\frac{5}{16}$ long—416 or 440 S.S. ^D
	108	2	Split sleeve—1 dia x 1 long—416 or 440 S.S. ^D
	109	1	Specimen—0.510 dia x $\frac{4}{3}$ long—Carbon
	110		Not Used
1B $\frac{3}{4}$ in. ^A grips	...	2	Item 101—Crosshead attachment yoke
	...	2	Item 102—Chain
	...	4	Item 103—Chain journal
	...	4	Item 104—Pin
	...	2	Item 105—Grip attachment yoke
	...	2	Item 106—Pin
	111	2	Grip sleeve—1½ dia x $2\frac{5}{16}$ long—416 or 440 S.S. ^D
	112	2	Split sleeve—1 dia x 1 long—416 or 440 S.S. ^D
	113	1	Specimen—0.760 dia x $\frac{4}{3}$ long—Carbon
	114		Not Used
1C 1¼ in. ^A grips	115	2	Crosshead attachment yoke—1½ dia x 4 long—416 or 440 S.S. ^D
	116	2	Chain— $\frac{5}{8}$ dia, 5100 pound tensile limit, 10 links long—Carbon Steel
	117	4	Chain journal— $\frac{5}{8}$ dia x $\frac{5}{8}$ long—416 or 440 S.S. ^D
	118	4	Pin— $\frac{3}{8}$ dia x 1½ long—Std Dowel
	119	2	Grip attachment yoke—1½ dia x $2\frac{5}{8}$ long—416 or 440 S.S. ^D
	120	2	Pin—½ shank dia with $\frac{3}{4}$ dia x $\frac{3}{4}$ long knurled head, total length $4\frac{1}{4}$, taper first half inch at 10°—416 or 440 S.S. ^D
	121	2	Grip sleeve—1½ dia x $3\frac{3}{8}$ long—416 or 440 S.S. ^D
	122	2	Split sleeve—1½ dia x $2\frac{1}{4}$ long—416 or 440 S.S. ^D
	123	1	Specimen—1¼ dia x $9\frac{3}{4}$ long—Carbon
	124		Not Used
1D 2 in. ^A grips	...	2	Item 115—Crosshead attachment yoke
	...	2	Item 116—Chain
	...	4	Item 117—Chain journal
	...	4	Item 118—Pin
	125	2	Grip attachment yoke—2¼ dia x $2\frac{5}{8}$ long—416 or 440 S.S. ^D
	126	2	Pin—½ shank dia with $\frac{3}{4}$ dia x $\frac{3}{4}$ long knurled head, total length $4\frac{1}{4}$, taper first half inch at 10°—416 or 440 S.S. ^D
	127	2	Grip sleeve—2¾ dia x $5\frac{1}{2}$ long—416 or 440 S.S. ^D
	128	2	Split sleeve—2¼ dia x 4 long—416 or 440 S.S. ^D
	129	1	Specimen—2.000 dia x $14\frac{3}{8}$ long—Carbon
	130		Not Used

^A 1 in. is equal to 25.4 mm.

^B Preload chain to yield using a load time recording.

^C Commercially available.

^D Or alternative high strength stainless steel.

carbons and graphites can be tested with uniform gauge diameters with minimum parasitic stresses to provide quality data for use in engineering applications rather than simply for quality control. This test method can be easily adapted to elevated temperature testing of carbons and graphites without changing the specimen size or configuration by simply utilizing elevated temperature materials for the load train. This test method has been utilized for temperatures as high as 4352°F (2400°C). The design of the fixtures (Figs. 2-9 and Table 1) and description of the procedures are intended to bring about, on the average, parasitic stresses of less than 5%. The specimens for the different graphites have been designed to ensure fracture within the gauge section commensurate with experienced variability in machining and testing care at different facilities. The constant gauge diameter permits rigorous analytical treatment.

5.2 Carbon and graphite materials exhibit significant physical property differences within parent materials. Exact sampling patterns and grain orientations must be specified in order to make meaningful tensile strength comparisons. See also Test Methods C565.

6. Apparatus

6.1 *Testing Machine*—The machine used for tensile testing shall conform to the requirements of Practices E4. The testing machine shall have a load measurement capacity such that the breaking load of the test specimen falls between 10 and 90 % of the scale or load cell capacity. This range must be linear to within 1 % over 1 % increments either by design or by calibration.

6.2 *Strain Measurements:*

TABLE 2 Sample Sizes Used in Round-Robin Tests (Suggested Specimen Size)^A

Material ^B	Max Grain Size, in.	Sample, in.	Specimen Size, in.	Recommended Shank and Maximum Gauge, in.
AXM-50	0.001	5 by 5 by 5, molded	1/2 by 0.200 ^C	1/2 by 3/16 3/4 by 1/4
9326	0.001	20 by 10 by 2, molded	1/2 by 1/4 3/4 by 0.3 1/2 by 3/16 ^C	1/2 by 3/16 3/4 by 1/4 1/2 by 3/16
9326A	0.001	20 by 10 by 2, molded	1/2 by 1/4 3/4 by 3/8 3/4 by 0.3 3/4 by 3/8	3/4 by 0.3
ATJ	0.006	13, rounds, molded	1/2 by 1/4 3/4 by 3/8 3/4 by 3/8 3/4 by 3/8	1/2 by 1/4 3/4 by 1/4 3/4 by 1/4
HLM	0.033	molded, 10 by 18 by 25	1/2 by 1/4 3/4 by 3/8 3/4 by 3/8 3/4 by 3/8	3/4 by 3/8
CS	0.030	10, rounds, extruded	2 by 1 3/4 by 3/8 1/2 by 1/4 1/2 by 1/4	3/4 by 3/8
AGR	0.250	25, rounds, extruded	2 by 1 2 by 1 2 by 1 1 1/4 by 3/8	2 by 1 1 1/4 by 5/8
CGE	0.265	14, rounds, extruded	2 by 1 1/4 3/4 by 1/2	2 by 1
Graphitar Grade 86	...	carbon-graphite, resin impregnated	3/4 by 1/4 1/2 by 1/4 ^C 1/2 by 1/4	3/4 by 1/4 1/2 by 0.2
Purebon P-59	...	carbon-graphite, copper treated	3/4 by 1/4 1/2 by 1/4 ^C 1/2 by 1/4	3/4 by 1/4 1/2 by 3/16

^A Based on Research Report RR:C05-1000 (see Section 11).

^B Identity of suppliers available from ASTM International Headquarters.

^C Gas-bearings.

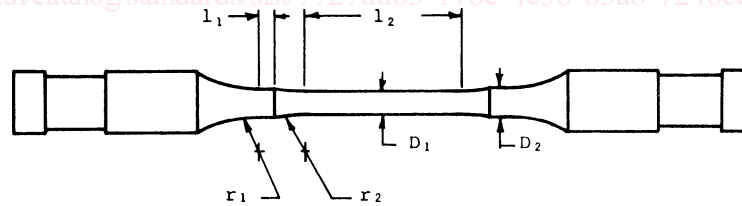

NOTE 1—Standard Specimen:

$$r_1 = r_2,$$

$$A_1 = A_2/1.2,$$

$$l_1 = D_2/2, \text{ and}$$

$$l_2 = 2 \text{ in. (51 mm) or } 8 D_1, \text{ whichever is greater.}$$

FIG. 1 Double Reduction Used to Minimize Radii-Fractures

6.2.1 The axial strain can be measured at room temperature by the use of strain gauges, mechanical extensometers, Tuckerman gauges, optical systems, or other devices applied diametrically opposite in the gauge length portion of the specimen. Two opposing gauges provide some compensation for bending and some assurance that it was not severe. Different graphites require different attachment procedures and extreme care is necessary. A proven device for mounting the specimen with minimum damage and for enabling the specimen to receive different extensometers is shown in Fig. 10. When attaching strain gauges, the modification of the surface may result in a glue-graphite composite at the skin and thus the resulting strain values may be erroneous and typically low. When using clip-on extensometers, the knife edges can initiate fracture. Record, but do not include the fractures at the attachments in the averages. If more than 20 % of the failures occur at the attachment location, change the strain monitoring system or attachment device.

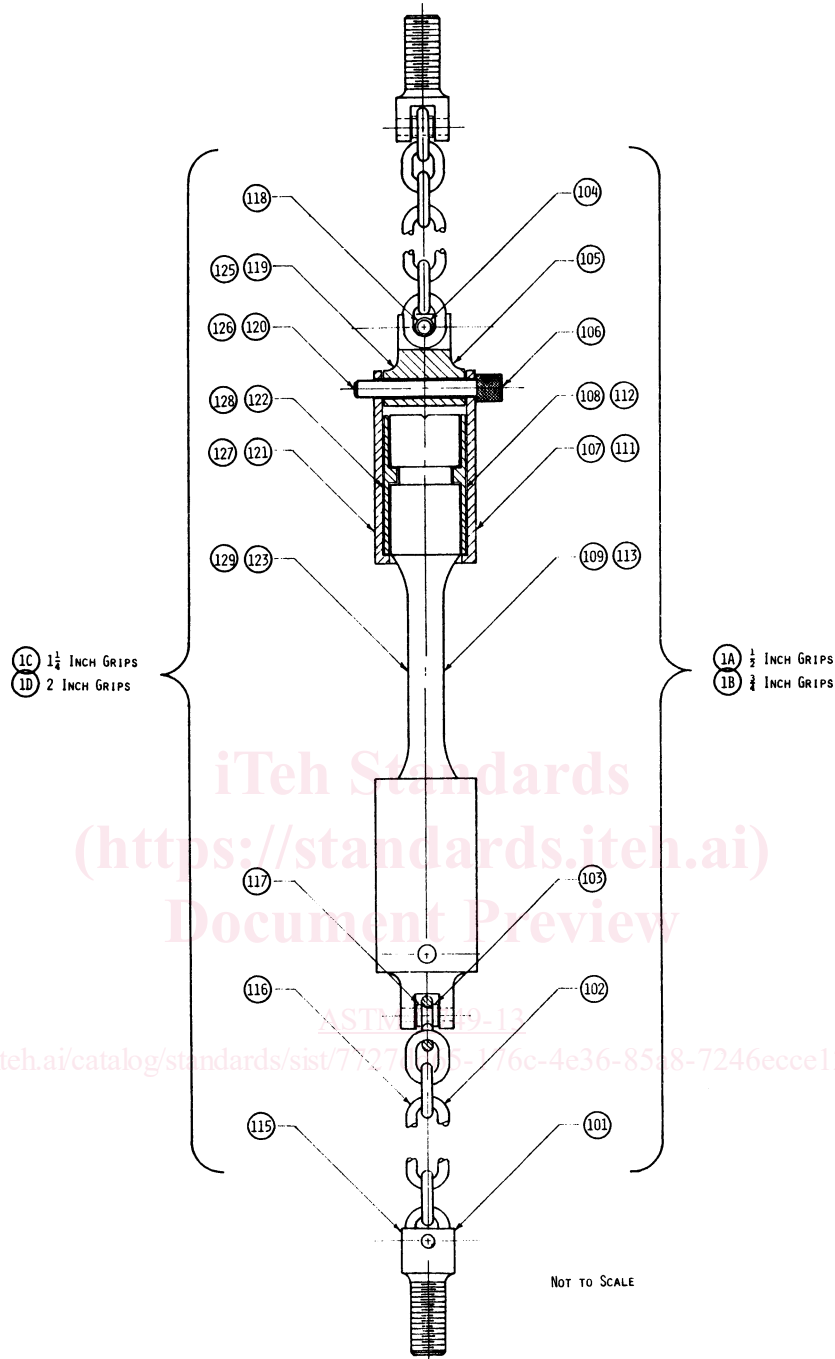

FIG. 2 Tensile Load Train Assembly

6.2.2 The circumferential strain can be measured at room temperature by use of strain gauges applied circumferentially. Knowledge of the anisotropy in the billet and orientation of the specimen is necessary in order to properly place the strain-measuring device. Generally, one can expect three values of Poisson's ratio for a nonisotropic material. Hence, the strain sensing devices must be sized and positioned carefully. Note the limitations on strain gauges mentioned in 6.2.1.

6.2.3 The diametral strains can be measured by most of the devices with limitations mentioned in 6.2.1 and 6.2.2.

6.3 *Parasitic Stress Monitor*—An optional parasitic stress monitor can be inserted as an extension of one of the grips. It shall be a steel rod about 4 in. long with strain gauges mounted at 90° angles to monitor axial bending moments on the rod and thus on the specimen. The rod shall be sized so that the bending moment applied to the specimen being used can be detected to within a 5 % parasitic stress in the outer fiber of the specimen. The parasitic stress shall be calculated elastically by translating the moment and assuming that the specimen is a free-end beam.

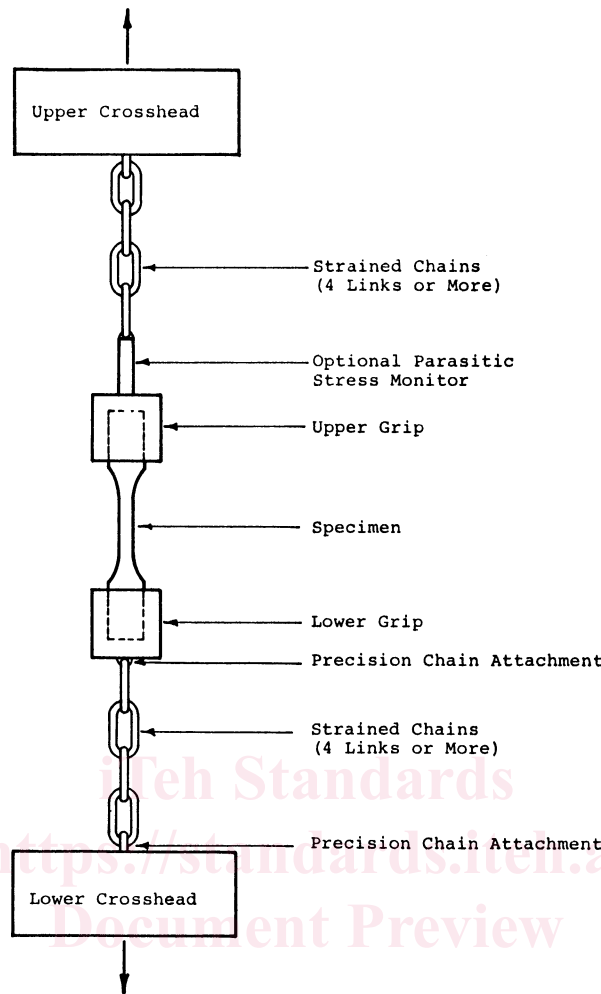

FIG. 3 Schematic of Tensile System for Carbon and Graphite

<https://standards.iteh.ai/catalog/standards/sist/7727dd65-176c-4e36-85a8-7246ecce120f/astm-c749-13>

6.4 *Gripping Devices*—Gripping devices that conform to those shown in Fig. 2 shall be used. The centerlines of all connections must align to within the tolerances shown throughout the test.

6.5 *General Test Arrangement*—The general arrangement of the specimen, flexible linkages, and crossheads shall be as shown in the schematic of Fig. 3.

7. Test Specimens

7.1 Test specimens shall be produced to the general configurations shown in Fig. 9. The selection of the proper ratio of shank to gauge diameter is important to prevent excessive head-pops or fracture of the specimen at the groove in the shanks. The ratios shown in Table 2 have been found satisfactory for this use. It is acceptable to double reduce gauge diameters as necessary (see Fig. 1) to eliminate head pops (or out-of-gauge fractures) or reduce them to an acceptable 20 % maximum of the total fractures. However, the reducing radius must be maintained near the values shown or excessive radii breaks will be obtained. Also, the gauge diameter should not be reduced to less than three to five times the maximum particles size in the material, or the failure mode may be atypical.

7.2 Improperly prepared test specimens often cause unsatisfactory test results. It is important, therefore, that care be exercised in the preparation of specimens both in minimizing end and side thrusts and in providing a quality surface. Either tool cutting or grinding is acceptable.

7.3 The gauge length of the specimen will be measured from the axial center of the specimen. Gauge marks can be applied with ink or layout dope but no scratching, punching, or notching of the specimen is permissible. The gauge length is to be used in referencing the point of fracture within 0.1 in. (2.5 mm). The total gauge length is defined as that section with the smaller uniform diameter extending from radius tangent to radius tangent plus 10 %. The additional 10 % is intended to accommodate the normal statistics of fracture for a material like graphite. However, at least 50 % of the specimens should fracture within the uniform diameter or the specimen should be redesigned and the system checked. Acceptable fracture locations are shown in Fig. 11.

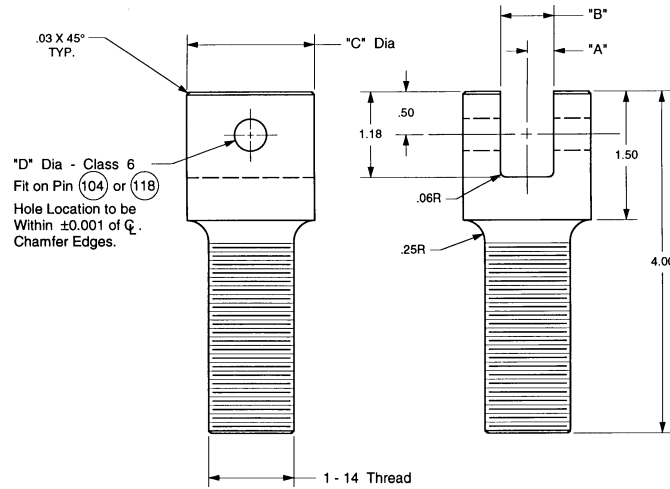

Dimensions, in. (mm)	Item	
	101	115
A	0.250 ± 0.001 (6.35 ± 0.03)	0.312 ± 0.001 (7.92 ± 0.03)
B	0.500 ± 0.001 (12.70 ± 0.03)	0.625 ± 0.001 (15.88 ± 0.03)
C	1.000 (25.40)	1.500 (38.10)
D	3/16 (4.76)	3/8 (9.52)

NOTE 1—Refer to Fig. 2, Items 101 and 115.

FIG. 4 Crosshead Attachment Yoke

7.4 To determine the cross-sectional area, the diameter of the specimen at the smaller or constant diameter region shall be used. The dimension shall be recorded to the nearest 0.001 in. (0.0254 mm).

8. Procedure

8.1 *Calibration*—Calibrate the micrometers that are to be used for measurement of diameters by measuring the dimensions of blocks provided by the NBS that are accurate within ±0.0001 in. (0.00254 mm). Calibrate all instrumentation and establish shunt calibration for each recorder and each parameter. Zero all recorders.

8.2 *Specimen*—Adapt to the specimen the appropriate strain instrumentation by bonding strain gauges to its surface, adapting, or any other strain measuring system so that strain can be measured during the test. Place the specimen within the load train. Make sure all instrumentation is properly calibrated and zeroed.

8.3 *Loading*—Apply the load at a predetermined constant stress rate by following the appropriate load time curve either manually or automatically. Continuously apply the load until fracture is induced.

8.4 *Recording*—During the entire load application duration, record the output of the load cell on the vertical axis of an X-Y recorder and the strain on the horizontal axis, and obtain a permanent record of the stress-strain curve for the specimen being tested during the entire test.

8.5 *Post Test*—Observe the specimen fracture surface. If the specimen failed outside the gauge length as defined in 6.3 (including head pops), the strength value measured must be reported but not included in the average.

9. Calculation

9.1 Calculate the strength as follows:

$$\sigma_{ult} = \frac{P_{max}}{A} \quad (1)$$

where:

σ_{ult} = tensile strength, psi (Pa),

P_{max} = maximum load, lbf (N), and

A = cross-sectional area of the specimen in the constant diameter region or gauge section, in.² (m²).

9.1.1 The cross-sectional area is given by the equation: