



**International  
Standard**

**ISO 16826**

**Non-destructive testing — Ultrasonic  
testing — Testing for discontinuities  
perpendicular to the surface**

*Essais non destructifs — Contrôle par ultrasons — Contrôle des  
discontinuités perpendiculaires à la surface*

**Second edition  
2025-03**

*Standards  
(<https://standards.iteh.ai>)  
Document Preview*

[ISO 16826:2025](https://standards.iteh.ai/catalog/standards/iso/9d0f1893-8ab3-4c2e-ba9c-7fea6dc92c0c/iso-16826-2025)

<https://standards.iteh.ai/catalog/standards/iso/9d0f1893-8ab3-4c2e-ba9c-7fea6dc92c0c/iso-16826-2025>

iTeh Standards  
(<https://standards.iteh.ai>)  
Document Preview

[ISO 16826:2025](https://standards.iteh.ai/catalog/standards/iso/9d0f1893-8ab3-4c2e-ba9c-7fea6dc92c0c/iso-16826-2025)

<https://standards.iteh.ai/catalog/standards/iso/9d0f1893-8ab3-4c2e-ba9c-7fea6dc92c0c/iso-16826-2025>



**COPYRIGHT PROTECTED DOCUMENT**

© ISO 2025

All rights reserved. Unless otherwise specified, or required in the context of its implementation, no part of this publication may be reproduced or utilized otherwise in any form or by any means, electronic or mechanical, including photocopying, or posting on the internet or an intranet, without prior written permission. Permission can be requested from either ISO at the address below or ISO's member body in the country of the requester.

ISO copyright office  
CP 401 • Ch. de Blandonnet 8  
CH-1214 Vernier, Geneva  
Phone: +41 22 749 01 11  
Email: [copyright@iso.org](mailto:copyright@iso.org)  
Website: [www.iso.org](http://www.iso.org)

Published in Switzerland

# Contents

Page

<b>Foreword</b> .....	<b>iv</b>
<b>Introduction</b> .....	<b>v</b>
<b>1 Scope</b> .....	<b>1</b>
<b>2 Normative references</b> .....	<b>1</b>
<b>3 Terms and definitions</b> .....	<b>1</b>
<b>4 Test equipment and test personnel</b> .....	<b>1</b>
<b>5 Tandem technique</b> .....	<b>2</b>
5.1 General.....	2
5.2 Probe movement.....	3
5.3 Time base setting.....	3
5.4 Sensitivity setting.....	3
5.5 Determination of test zones.....	4
5.6 Depth-gain diagram for tandem technique.....	5
5.7 Corrections of sensitivity.....	6
5.8 Test objects with concentric surfaces.....	6
5.8.1 General.....	6
5.8.2 Scanning on a concave surface.....	7
5.8.3 Scanning on a convex surface.....	7
<b>6 Longitudinal-longitudinal-transverse wave technique</b> .....	<b>8</b>
6.1 General.....	8
6.2 Time base setting and determination of depth of a discontinuity.....	9
6.3 Sensitivity setting.....	10
6.4 Determination of the depth of the intersection of the beam axes.....	10
6.5 Sensitivity diagram for LLT technique.....	11
6.6 Correction of sensitivity.....	11
<b>Annex A (informative) Nomograms for tandem distances for convex and concave surfaces</b> .....	<b>12</b>
<b>Bibliography</b> .....	<b>15</b>

<https://standards.iteh.ai/catalog/standards/iso/9d0f1893-8ab3-4c2e-ba9c-7fea6dc92c0c/iso-16826-2025>

## Foreword

ISO (the International Organization for Standardization) is a worldwide federation of national standards bodies (ISO member bodies). The work of preparing International Standards is normally carried out through ISO technical committees. Each member body interested in a subject for which a technical committee has been established has the right to be represented on that committee. International organizations, governmental and non-governmental, in liaison with ISO, also take part in the work. ISO collaborates closely with the International Electrotechnical Commission (IEC) on all matters of electrotechnical standardization.

The procedures used to develop this document and those intended for its further maintenance are described in the ISO/IEC Directives, Part 1. In particular, the different approval criteria needed for the different types of ISO document should be noted. This document was drafted in accordance with the editorial rules of the ISO/IEC Directives, Part 2 (see [www.iso.org/directives](http://www.iso.org/directives)).

ISO draws attention to the possibility that the implementation of this document may involve the use of (a) patent(s). ISO takes no position concerning the evidence, validity or applicability of any claimed patent rights in respect thereof. As of the date of publication of this document, ISO had not received notice of (a) patent(s) which may be required to implement this document. However, implementers are cautioned that this may not represent the latest information, which may be obtained from the patent database available at [www.iso.org/patents](http://www.iso.org/patents). ISO shall not be held responsible for identifying any or all such patent rights.

Any trade name used in this document is information given for the convenience of users and does not constitute an endorsement.

For an explanation of the voluntary nature of standards, the meaning of ISO specific terms and expressions related to conformity assessment, as well as information about ISO's adherence to the World Trade Organization (WTO) principles in the Technical Barriers to Trade (TBT), see [www.iso.org/iso/foreword.html](http://www.iso.org/iso/foreword.html).

This document was prepared by Technical Committee ISO/TC 135, *Non-destructive testing*, Subcommittee SC 3, *Ultrasonic testing*, in collaboration with the European Committee for Standardization (CEN) Technical Committee CEN/TC 138, *Non-destructive testing*, in accordance with the Agreement on technical cooperation between ISO and CEN (Vienna Agreement).

This second edition cancels and replaces the first edition (ISO 16826:2012), which has been technically revised.

The main changes are as follows:

- revised figures and formulae;
- editorial revisions.

Any feedback or questions on this document should be directed to the user's national standards body. A complete listing of these bodies can be found at [www.iso.org/members.html](http://www.iso.org/members.html).

## Introduction

The following documents on ultrasonic testing are linked:

ISO 16810, *Non-destructive testing — Ultrasonic testing — General principles*

ISO 16811, *Non-destructive testing — Ultrasonic testing — Sensitivity and range setting*

ISO 16823, *Non-destructive testing — Ultrasonic testing — Through-transmission technique*

ISO 16826, *Non-destructive testing — Ultrasonic testing — Testing for discontinuities perpendicular to the surface*

ISO 16827, *Non-destructive testing — Ultrasonic testing — Characterization and sizing of discontinuities*

ISO 16828, *Non-destructive testing — Ultrasonic testing — Time-of-flight diffraction technique as a method for detection and sizing of discontinuities*

iTeh Standards  
(<https://standards.iteh.ai>)  
Document Preview

[ISO 16826:2025](https://standards.iteh.ai/catalog/standards/iso/9d0f1893-8ab3-4c2e-ba9c-7fea6dc92c0c/iso-16826-2025)

<https://standards.iteh.ai/catalog/standards/iso/9d0f1893-8ab3-4c2e-ba9c-7fea6dc92c0c/iso-16826-2025>



# Non-destructive testing — Ultrasonic testing — Testing for discontinuities perpendicular to the surface

## 1 Scope

This document specifies principles for the tandem technique and the longitudinal-longitudinal-transverse wave (LLT) technique for detection of discontinuities perpendicular to the surface or almost perpendicular to the surface.

The general principles for ultrasonic testing of industrial products are described in ISO 16810.

The tandem or LLT techniques can be used for the detection of embedded planar discontinuities.

This document gives guidelines for the testing of metallic materials with a thickness between 40 mm and 500 mm with parallel or concentric surfaces.

The procedures provided in this document can be used for testing of other materials or smaller thickness if special measures are taken according to a written testing procedure.

Phased array techniques can also be applied for the tandem technique and the LLT technique, but additional steps or verifications can be needed.

## 2 Normative references

The following documents are referred to in the text in such a way that some or all of their content constitutes requirements of this document. For dated references, only the edition cited applies. For undated references, the latest edition of the referenced document (including any amendments) applies.

ISO 5577, *Non-destructive testing — Ultrasonic testing — Vocabulary*

ISO 16810, *Non-destructive testing — Ultrasonic testing — General principles*

## 3 Terms and definitions

For the purposes of this document, the terms and definitions given in ISO 5577 apply.

ISO and IEC maintain terminology databases for use in standardization at the following addresses:

- ISO Online browsing platform: available at <https://www.iso.org/obp>
- IEC Electropedia: available at <https://www.electropedia.org/>

## 4 Test equipment and test personnel

The requirements of ISO 16810 on test equipment and test personnel shall be applied unless stated otherwise.

## 5 Tandem technique

### 5.1 General

- The testing normally shall be carried out using two similar 45° angle-beam transverse wave probes, one probe operating as transmitter and the other probe as receiver.
- For wall thicknesses larger than 160 mm, different transducer sizes for the transmitter probe and the receiver probe should be used to ensure approximately the same beam dimensions in the test zone.
- The use of beam angles other than 45° may be necessary to comply with particular geometrical conditions of the test object and/or the orientation of the expected discontinuity.
- Beam angles that give rise to mode conversion shall be avoided.

NOTE For a test object with parallel surfaces, the use of transverse wave probes with a beam angle of 60° results in the beam impinging on the reference line at 30°, which can result in mode conversion on a discontinuity in steel test objects.

- The probes shall be located in a line with their beam axes in the same direction.

The sound beam from the rear probe will, after reflection from the opposite surface, intersect the sound beam from the front probe, as shown in [Figure 1](#). The area of intersection of the beams is the test zone. The intersection of the beam axes is the centre of the test zone, located at the reference line.

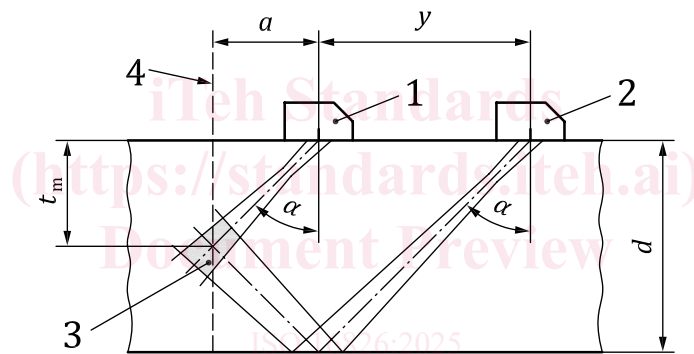

**Key**

1	front probe	$d$	material thickness
2	rear probe	$t_m$	depth of the intersection of the beam axes
3	test zone	$y$	probe distance
4	reference line	$\alpha$	beam angle
$a$	projected distance		

**Figure 1 — Basic principle of tandem technique**

When testing objects with plane parallel surfaces, the distance between the probes can be determined using [Formula \(1\)](#):

$$y = 2(d - t_m) \tan \alpha \quad (1)$$

For 45° beam angles [Formula \(2\)](#) can be used:

$$y = 2(d - t_m) \quad (2)$$



where

$d$  is the material thickness;

$t_m$  is the depth of the intersection of the beam axes;

$\alpha$  is the beam angle.

## 5.2 Probe movement

Probe movement (scanning) shall be performed in either of the following ways:

- a) both probes shall be moved along the surface with a fixed probe distance ( $y$ ).

In this way only one test zone is covered at a time, and the scanning shall be repeated with different probe distances until the complete test volume has been tested;

- b) both probes shall be moved simultaneously but in opposite directions (forward and backward respectively), such that the sum of their distances from the reference line [ $a + (a + y)$ ] remains constant, thereby scanning the full thickness of the test object in one continuous movement, as shown in [Figure 2](#).

For example, the reference line can be the vertical weld axis.

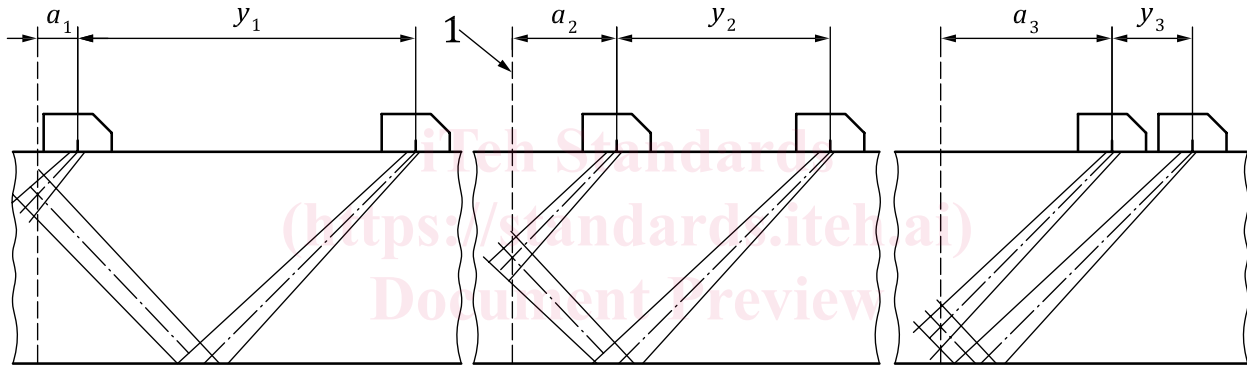

### Key

1 reference line

$a_1, a_2, a_3$  projected distance

$y_1, y_2, y_3$  probe distance

Figure 2 — Probes at different distances for test zones at different depths (schematic)

## 5.3 Time base setting

All relevant echoes will appear at the same sound path distance, which corresponds to the sound path for full skip for probes with the beams in opposite directions. Therefore, the setting of the time base is not critical. However, the echo of the signal along this path should be located at a specified position, e.g. at 80 % of full screen width, and indications in the vicinity of this specified position should be also displayed/recorded.

## 5.4 Sensitivity setting

The setting of sensitivity shall be performed using one of the following reflector types:

- a) the opposite surface, where the back-wall echo is used;
- b) disc-shaped reflectors perpendicular to the scanning surface (e.g. flat-bottomed holes), which shall be located at the intersection of the beam axes;
- c) side-drilled holes located at the intersection of the beam axes and at the borders of the test zones.

### 5.5 Determination of test zones

Because of beam divergence, the shape of the test zone is not exactly a square or a rectangle and the dimensions of the test zone vary depending on the depth of the test zone.

- a) To ensure that the sensitivity throughout the thickness does not fall below a certain level, a sufficient number of test zones shall be used to cover the thickness of the test object taking the beam divergence into account.
- b) The probes shall be selected to ensure suitable beam characteristics, especially in the area near the test surface due to the near field length of the front probe.

The test zone near the opposite surface can require that the transducers for both beams are mounted in a single probe housing.

The test zones at the surfaces may be tested using a single probe with pulse-echo technique to detect corner reflections.

- c) The height of the test zone ( $t_z$ ) is defined as the height of the test zone at the reference line through the intersection point of the beam axes, see [Figure 3](#).
- d) The height of the test zones shall be selected so that the sensitivity at the edges of the test zones is not more than 6 dB below the sensitivity in the intersection point of the beam axes.

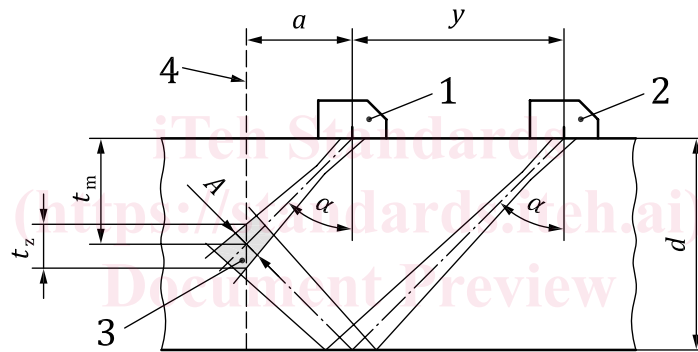

**Key**

- |     |                                   |          |  |
|-----|-----------------------------------|----------|--|
| 1   | front probe                       | $t_m$    | depth of the intersection of the beam axes |
| 2   | rear probe                        | $t_z$    | height of the test zone                    |
| 3   | test zone                         | $\alpha$ | beam angle                                 |
| 4   | reference line                    | $a$      | projected distance                         |
| A   | beam dimension of the front probe | $y$      | probe distance                             |
| $d$ | material thickness                |          |  |

**Figure 3 — Height of test zone**

- e) The height of each test zone ( $t_z$ ) shall be determined by using a reference block with reflectors at different depths or approximated using [Formula \(3\)](#), based on the dimension  $A$  of the direct beam in the test zone (6 dB drop), see [Figure 3](#).