



Designation: **F1959/F1959M – 12 F1959/F1959M – 13**

Standard Test Method for Determining the Arc Rating of Materials for Clothing¹

This standard is issued under the fixed designation F1959/F1959M; the number immediately following the designation indicates the year of original adoption or, in the case of revision, the year of last revision. A number in parentheses indicates the year of last reapproval. A superscript epsilon (ϵ) indicates an editorial change since the last revision or reapproval.

1. Scope

1.1 This test method is used to measure the arc rating of materials intended for use as flame resistant clothing for workers exposed to electric arcs that would generate heat flux rates from 84 to 25 120 kW/m² [2 to 600 cal/cm²s].

1.2 This test method will measure the arc rating of materials which meet the following requirements: less than 150 mm [6 in.] char length and less than 2 s afterflame when tested in accordance with Test Method **D6413**.

1.2.1 It is not the intent of this test method to evaluate non flame-resistant materials except where used as under layers in multiple-layer specimens.

1.3 The materials used in this test method are in the form of flat specimens.

1.4 This test method shall be used to measure and describe the properties of materials, products, or assemblies in response to convective and radiant energy generated by an electric arc under controlled laboratory conditions.

1.5 The values stated in SI units shall be regarded as standard except as noted. Within the text, alternate units are shown in brackets. The values stated in each system may not be exact equivalents therefore alternate systems must be used independently of the other. Combining values from the systems described in the text may result in nonconformance with the method.

1.6 This test method does not apply to electrical contact or electrical shock hazards.

1.7 *This standard shall not be used to describe or appraise the fire hazard or fire risk of materials, products, or assemblies under actual fire conditions. However, results of this test may be used as elements of a fire assessment which takes into account all of the factors which are pertinent to an assessment of the fire hazard of a particular end use.*

1.8 *This standard does not purport to address all of the safety concerns, if any, associated with its use. It is the responsibility of the user of this standard to establish appropriate safety and health practices and determine the applicability of regulatory requirements prior to use. For specific precautions, see Section 7.*

2. Referenced Documents

2.1 *ASTM Standards:*²

D123 Terminology Relating to Textiles

D1776 Practice for Conditioning and Testing Textiles

D4391 Terminology Relating to The Burning Behavior of Textiles

D6413 Test Method for Flame Resistance of Textiles (Vertical Test)

E457 Test Method for Measuring Heat-Transfer Rate Using a Thermal Capacitance (Slug) Calorimeter

F1494 Terminology Relating to Protective Clothing

2.2 *ANSI/IEEE Standard:*³

Standard Dictionary of Electrical and Electronics Terms

2.3 *AATCC Standard:*⁴

AATCC Method 135-2001 Dimensional Changes in Automatic Home Laundering of Woven and Knit Fabrics

¹ This test method is under the jurisdiction of ASTM Committee **F18** on Electrical Protective Equipment for Workers and is the direct responsibility of Subcommittee **F18.65** on Wearing Apparel.

Current edition approved Oct. 1, 2012. Published November 2012. Originally approved in 1997. Last previous edition approved in 2006 as **F1959/F1959M – 06a**; **F1959/F1959M – 12**. DOI: 10.1520/F1959_F1959M-12; 10.1520/F1959_F1959M-13.

² For referenced ASTM standards, visit the ASTM website, www.astm.org, or contact ASTM Customer Service at service@astm.org. For *Annual Book of ASTM Standards* volume information, refer to the standard's Document Summary page on the ASTM website.

³ Available from Institute of Electrical and Electronics Engineers, Inc. (IEEE), 445 Hoes Ln., P.O. Box 1331, Piscataway, NJ 08854-1331.

⁴ Technical Manual of the American Association of Textile Chemists and Colorists.

3. Terminology

3.1 Definitions:

3.1.1 *ablation, n*—in electrical arc testing, a physical response evidenced by significant erosion or the formation of one or more large holes in a layer of a multilayer system.

3.1.1.1 Discussion—

Any layer in a specimen (other than the innermost layer) is considered to exhibit ablation when the material removal or any hole is at least 16 cm² [2.5 in.²] in area or at least 8 cm [3.1 in.] in length in any dimension. Single threads across the opening or hole do not reduce the size of the hole for the purposes of this test method. Ablation in one or more layers of material in a multilayer system may remove energy from the specimen. (See 11.2.7.)

3.1.2 *ablation response energy (E_{ab}), n*—the incident energy on a multilayer system that results in a 50 % probability of the physical response of ablation.

3.1.3 *arc duration, n*—time duration of the arc, s.

3.1.4 *arc energy, vi dt, n*—sum of the instantaneous arc voltage values multiplied by the instantaneous arc current values multiplied by the incremental time values during the arc, J.

3.1.5 *arc gap, n*—distance between the arc electrodes, cm [in.].

3.1.6 *arc rating, n*—value attributed to materials that describes their performance to exposure to an electrical arc discharge.

3.1.6.1 Discussion—

The arc rating is expressed in cal/cm² and is derived from the determined value of ATPV or E_{BT} (should a material system exhibit a breakopen response below the ATPV value) derived from the determined value of ATPV or E_{BT} (should a material system exhibit a breakopen response below the ATPV value).

3.1.7 *arc thermal performance value (ATPV), n*—the incident energy on a material or a multilayer system of materials that results in a 50 % probability that sufficient heat transfer through the tested specimen is predicted to cause the onset of a second-degree skin burn injury based on the Stoll⁵ curve, kW/m² [cal/cm²].

3.1.8 *arc voltage, n*—voltage across the gap caused by the current flowing through the resistance created by the arc gap, V.

3.1.9 *asymmetrical arc current, n*—the total arc current produced during closure; it includes a direct component and a symmetrical component, A.

3.1.10 *blowout, n*—the extinguishing of the arc caused by a magnetic field.

3.1.11 *breakopen, n*—in electric arc testing, a material response evidenced by the formation of one or more holes in the material which may allow thermal energy to pass through the material.

⁵ Derived from: Stoll, A. M. and Chianta, M. A., "Method and Rating System for Evaluations of Thermal Protection," *Aerospace Medicine*, Vol 40, 1969, pp. 1232-1238 and Stoll, A. M. and Chianta, M. A., "Heat Transfer through Fabrics as Related to Thermal Injury," *Transactions—New York Academy of Sciences*, Vol 33 (7), Nov. 1971, pp. 649-670.

3.1.11.1 Discussion—

The specimen is considered to exhibit breakopen when any hole is at least 1.6 cm² [0.5 in.²] in area or at least 2.5 cm [1.0 in.] in any dimension. Single threads across the opening or hole do not reduce the size of the hole for the purposes of this test method. In multiple layer specimens of flame resistant material, all the layers must breakopen to meet the definition. In multiple layer specimens, if some of the layers are ignitable, breakopen occurs when these layers are exposed.

3.1.12 *breakopen threshold energy (E_{BT}), n*—the incident energy on a material or material system that results in a 50 % probability of breakopen.

3.1.12.1 Discussion—

This is the value in J/cm² [cal/cm²] determined by use of logistic regression analysis representing the energy at which breakopen of the layer occurred.

3.1.13 *charring, n*—the formation of carbonaceous residue as the result of pyrolysis or incomplete combustion.

3.1.14 *dripping, n*—in testing flame-resistant clothing, a material response evidenced by flowing of a specimen's material of composition.

3.1.15 *embrittlement, n*—the formation of a brittle residue as the result of pyrolysis or incomplete combustion.

3.1.16 *heat attenuation factor, HAF, n*—in *electric arc testing*, the percent of the incident energy that is blocked by a material at an incident energy level equal to ATPV.

3.1.17 *heatflux, n*—the thermal intensity indicated by the amount of energy transmitted divided by area and time kW/m^2 [$\text{cal/cm}^2\text{s}$].

3.1.18 $i^2 t, n$ —sum of the instantaneous arc current values squared multiplied by the incremental time values during the arc, A^2/s .

3.1.19 *ignitability, n (ignitable, adj)*—in *electric arc exposure*, the property of a material involving ignition accompanied by heat and light, and continued burning resulting in consumption of at least 25 % of the exposed area of the test specimen.

3.1.20 *ignition, n*—the initiation of combustion.

3.1.21 *ignition₅₀, n*—the incident energy on a fabric or material that results in a 50 % probability that sufficient heat transfer through the tested specimen is predicted to cause ignition of a flammable underlayer.

3.1.22 *incident energy monitoring sensors, n*—sensors mounted on each side of the panel, using the calorimeters described in 6.3, not covered by test material, used to measure incident energy.

3.1.23 *incident energy (E_i), n*—the total heat energy received at the surface of the panel as a direct result of an electric arc.

3.1.24 *material response, n*—material response to an electric arc is indicated by the following terms: breakopen, melting, dripping, charring, embrittlement, shrinkage, and ignition.

3.1.25 *melting, n*—in *testing flame resistant clothing*, a material response evidenced by softening of the material.

3.1.26 *mix zone, n*—in *arc testing*, the range of incident energies, which can result in either a positive or negative outcome for predicted second-degree burn injury, breakopen or underlayer ignition. The low value of the range begins with the lowest incident energy indicating a positive result, and the high value of the range is the highest incident energy indicating a negative result.

3.1.26.1 *Discussion*—

A mix zone is established when the highest incident energy with a negative result is greater than the lowest incident energy with a positive result.

3.1.27 *peak arc current, n*—maximum value of the AC arc current, A .

3.1.28 *RMS arc current, n*—root mean square of the AC arc current, A .

3.1.29 *shrinkage, n*—in *testing flame resistant clothing*, a material response evidenced by reduction in specimen size.

3.1.30 *Stoll curve⁵, n*—an empirical predicted second-degree skin burn injury model, also commonly referred to as the *Stoll Response*.

3.1.31 *X/R ratio*—the ratio of system inductive reactance to resistance. It is proportional to the L/R ratio of time constant, and is, therefore, indicative of the rate of decay of any DC offset. A large X/R ratio corresponds to a large time constant and a slow rate of decay.

3.2 For definitions of other textile terms used in this test method, refer to Terminologies **D123**, **D4391**, and **F1494**.

4. Summary of Test Method

4.1 This test method determines the heat transport response through a material, fabric, or fabric system when exposed to the heat energy from an electric arc. This heat transport response is assessed versus the Stoll curve, an approximate human tissue tolerance predictive model that projects the onset of a second-degree burn injury.

4.1.1 During this procedure, the amount of heat energy transferred by the tested material is measured during and after exposure to an electric arc.

4.1.1.1 The thermal energy exposure and heat transport response of test specimens are measured with copper slug calorimeters. The change in temperature versus time is used, along with the known thermo-physical properties of copper to determine the respective heat energies delivered to and through the specimens.

4.2 Material performance for this procedure is determined from the amount of heat transferred by and through the tested material.

4.3 Heat transfer data determined by this test method is the basis of the arc rating for the material.

4.3.1 The arc rating determined by this test method is the amount of energy that predicts a 50 % probability of second-degree burn as determined by the Stoll Curve or breakopen (should the specimen exhibit breakopen before the skin burn injury prediction is reached).

4.4 Material response shall be further described by recording the observed effects of the electric arc exposure on the specimens using the terms in 12.6.

5. Significance and Use

5.1 This test method is intended for the determination of the arc rating of a material, or a combination of materials.

5.1.1 Because of the variability of the arc exposure, different heat transmission values may be observed at individual sensors. Evaluate the results of each sensor in accordance with Section 12.

5.2 This test method maintains the specimen in a static, vertical position and does not involve movement except that resulting from the exposure.

5.3 This test method specifies a standard set of exposure conditions. Different exposure conditions may produce different results. In addition to the standard set of exposure conditions, other conditions representative of the expected hazard may be used and shall be documented in the reporting of the testing results.

6. Apparatus

6.1 *General Arrangement For Determining Arc Rating Using Three Two-Sensor Panels and Monitor Sensors*—The test apparatus shall consist of supply bus, arc controller, recorder, arc electrodes, three two-sensor panels, and monitor sensors.

6.1.1 *Arrangement of the Two-Sensor Panels*—Three two-sensor panels shall be used for each test and be spaced equally as shown in Fig. 1. Each two-sensor panel shall have two monitoring sensors. One monitoring sensor shall be positioned on each side of the two-sensor panel as shown in Fig. 2.

6.1.1.1 *Monitor sensors located at a radius different from the two-sensor panels shall be employed when the incident energy from the arc exposure results in monitor sensor temperature values that exceed the maximum allowed operating characteristic of the copper calorimeter. See 11.1.1. Monitor sensors shall be positioned whereby there is a clear, unobstructed path between the sensors and the arc electrode centerline.*

6.1.2 *Panel Construction*—Each two-sensor panel and each monitor sensor holder shall be constructed from non-conductive heat resistant material with a thermal conductivity value of < 0.15 W/mK, high temperature stability, and resistance to thermal shock. The board shall be nominally 1.3 cm [0.5 in.] or greater in thickness.

6.1.3 Each two-sensor panel shall be 20.3 × 54.6 cm ± 1.3 cm [8 × 21.5 in. ± 0.5 in.] as shown in Fig. 2. Each two-sensor panel and monitoring sensors shall be independently adjustable from 20.0 cm [8 in.] to 60.0 cm [24 in.] from the centerline of the arc electrodes as shown in Fig. 1 and Fig. 3. R_1 is the radius from the centerline of the arc electrodes to the surface of the two-sensor panels and r_2 is the radius from the centerline of the arc electrodes to the surface of the monitor sensors.

6.1.4 Two sensors shall be mounted in the panel as shown in Fig. 2. Each sensor shall be mounted flush with the surface of the mounting board.

6.1.5 Additional calorimeters are allowed for installation as monitor and panel sensors for experimental purposes. The information from these sensors shall not be used as substitutes for the current test apparatus in the determination of ATPV, breakopen, or ignition performance.

6.2 Sensors:

ASTM F1959/F1959M-13

<https://standards.iteh.ai/catalog/standards/sist/5d5d3e9a-d64e-4d5e-92cf-be10ec2a8319/astm-f1959-f1959m-13>

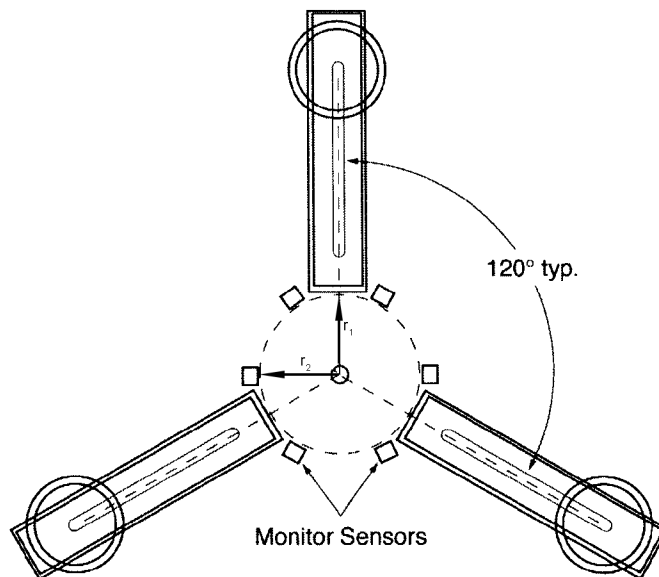

r_1 = radius of two-sensor panels
 r_2 = radius of monitor sensors
 r_1, r_2 = 20-60 cm [8-24 in.]

FIG. 1 Arrangement of Three Panel Sensors with Monitor Sensors

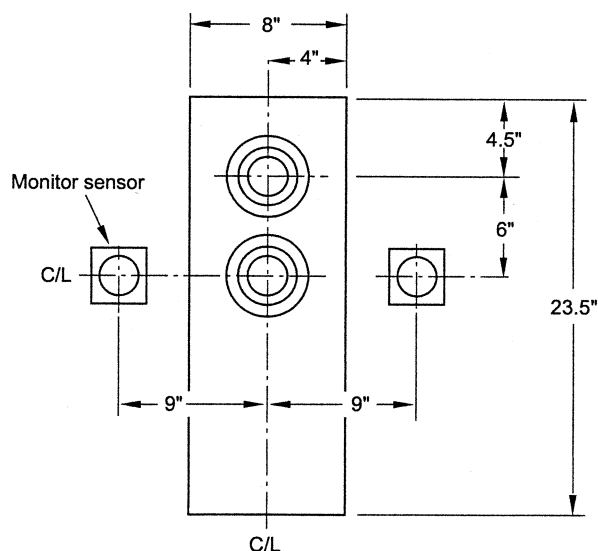

FIG. 2 Two Sensor Panel (Face View) with Monitor Sensors

6.2.1 The panel and monitor sensors shall be copper slug calorimeters constructed from electrical grade copper with a single thermocouple wire installed as identified in Fig. 5 (see Test Method E457 for information regarding slug calorimeters).

6.2.2 The exposed surface of the copper slug calorimeters shall be painted with a thin coating of a flat black high temperature spray paint with an emissivity of >0.9 . The painted sensor shall be dried before use and present a uniformly applied coating (no visual thick spots or surface irregularities). Note that an external heat source, for example, an external heat lamp, may be required to completely drive off any remaining organic carriers in a freshly painted surface.

6.2.2.1 Discussion—An evaluation of the emissivity of the painted calorimeters used in this test method is available from ASTM; “ASTM Research Program on Electric Arc Test Method Development to Evaluate Protective Clothing Fabric; ASTM F18.65.01 Testing Group Report on Arc Testing Analysis of the F1959 Standard Test Method—Phase 1.”

6.2.3 The thermocouple wire is installed in the calorimeter as shown in Fig. 6.

6.2.4 Alternate calorimeters are permitted for use as monitor sensors provided they are calibrated and have a similar response to those in 6.2.1. The use of a different thermocouple junction, exposed surface area, slug material, and mass are allowed and their performance shall be documented in the test results.

6.3 Supply Bus and Electrodes—A typical arrangement of the supply bus and arc electrodes is shown in Fig. 7. The arc shall be in a vertical position as shown.

6.3.1 Electrodes—Make the electrodes from stainless steel (Alloy Type 303 or Type 304) rod of a nominal 19 mm [0.75 in.] diameter. Lengths of 45.0 cm [18 in.] long initially have been found to be adequate.

6.3.2 Fuse Wire—A fuse wire, connecting the ends of opposing electrodes tips, is used to initiate the arc. This wire is consumed during the test; therefore, its mass shall be very small to reduce the chance of molten metal burns. The fuse wire shall be a copper wire with a diameter not greater than 0.05 mm [0.02 in.].

6.4 Electric Supply—The electric supply should be sufficient to allow for the discharge of an electric arc with a gap of up to 305 mm [12 in.] with alternating arc current from 4000 up to 25 000 amperes and with arc duration from 3 cycles (0.05 s) up to 90 cycles (1.5 s) from a 60 Hz supply. The X/R ratio of the test circuit shall be such that the test current contains a DC component resulting in the first peak of the test current having a magnitude of 2.3 times the symmetrical RMS value.

6.5 Test Circuit Control—Repeat exposures of the arc currents shall not deviate more than 2 % per test from the selected test level. The make switch shall be capable of point on wave closing within 0.2 cycles from test to test such that the closing angle will produce maximum asymmetrical current with an X/R ratio of the test circuit as stated in 6.4. The arc current, duration, and voltage shall be measured. The arc current, duration, voltage and energy shall be displayed in graph form and stored in digital format.

6.6 Data Acquisition System—The system shall be capable of recording voltage, current, and sufficient calorimeter outputs as required by the test.

6.6.1 The temperature data (copper slug calorimeter outputs) shall be acquired at a minimum sampling rate of 20 samples per second per calorimeter. The acquisition system shall be able to record temperatures to 400°C. The temperature acquisition system shall have at least a resolution of 0.1°C and an accuracy of $\pm 0.75^\circ\text{C}$.

6.6.2 The system current and voltage data shall be acquired at a minimum rate of 2000 samples per second. The current and voltage acquisition system shall have at least a resolution of 1 % of the applied voltage and current.

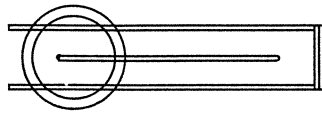

Slide system provided by user shall include method to maintain alignment and locking device

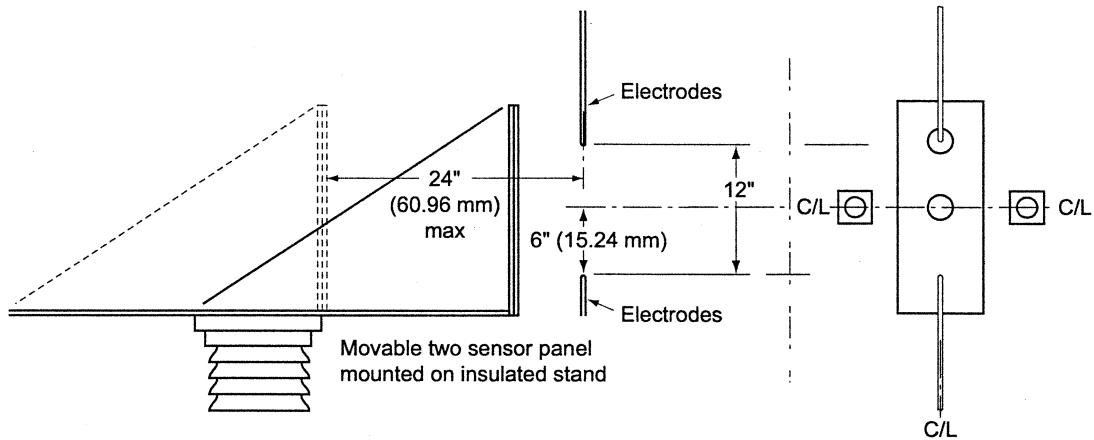

FIG. 3 Sliding Two Sensor Panel

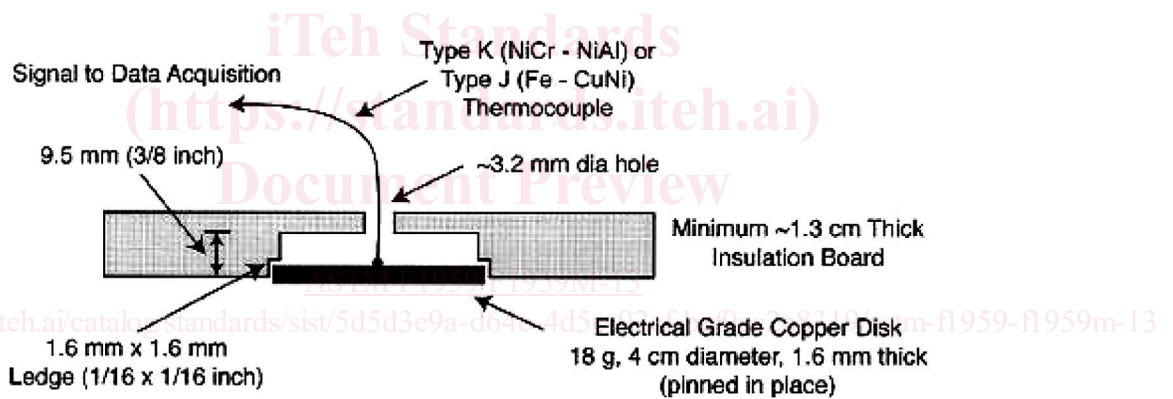

FIG. 4 Calorimeter and Thermocouple Detail

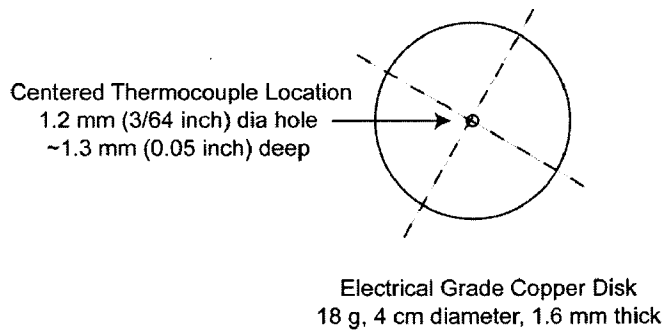

FIG. 5 Calorimeter

6.7 *Data Acquisition System Protection*—Due to the nature of this type of testing, the use of isolating devices on the calorimeter outputs to protect the acquisition system is recommended.