



Designation: **D6381–08 D6381/D6381M – 08 (Reapproved 2013)<sup>ε1</sup>**

## Standard Test Method for Measurement of Asphalt Shingle Mechanical Uplift Resistance<sup>1</sup>

This standard is issued under the fixed designation ~~D6381~~; D6381/D6381M; the number immediately following the designation indicates the year of original adoption or, in the case of revision, the year of last revision. A number in parentheses indicates the year of last reapproval. A superscript epsilon ( $\epsilon$ ) indicates an editorial change since the last revision or reapproval.

---

<sup>ε1</sup> NOTE—Units information was editorially corrected in November 2013.

---

### 1. Scope

1.1 This test method covers measuring the uplift resistance of asphalt roofing shingles by mechanical means. It is applicable to shingles that use a factory-applied or field-applied sealant.

1.2 There are several types of shingles designed for service without a factory-applied or field-applied sealant. These shingles, when applied in accordance with the manufacturers' application instructions, employ other means to provide resistance against the forces generated by the action of wind such as geometry and shingle construction. Field experience has shown that these types of shingles function satisfactorily in service. Because there are a variety of these shingle designs, it is not practical to describe in this test method how to test these shingles for uplift resistance. The testing of these types of shingles, therefore, goes beyond the scope of this test method.

1.3 This test method describes two procedures for measuring shingle uplift resistance. Procedure A employs a specially designed apparatus with a clamping device which facilitates lifting of the edge of the shingle and measuring the force required to break the seal. Procedure B employs a metal "T" section adhered to the weather surface of the shingle to facilitate application and measurement of a perpendicular force to break the seal.

1.4 It is not prohibited to use this test method over a range of sealing time and temperature combinations and testing temperatures to simulate a variety of actual field use conditions. The times and temperatures used shall be stated in the report.

1.5 The values stated in either SI units or inch-pound units are to be regarded separately as standard. ~~The values given in parentheses are mathematical conversions to inch-pound units that are provided for information only and are not considered standard.~~ stated in each system may not be exact equivalents; therefore, each system shall be used independently of the other. Combining values from the two systems may result in non-conformance with the standard.

1.6 *This standard does not purport to address all of the safety concerns, if any, associated with its use. It is the responsibility of the user of this standard to establish appropriate safety and health practices and determine the applicability of regulatory limitations prior to use.*

### 2. Referenced Documents

2.1 *ASTM Standards:*<sup>2</sup>

[D228 Test Methods for Sampling, Testing, and Analysis of Asphalt Roll Roofing, Cap Sheets, and Shingles Used in Roofing and Waterproofing](#)

[D1079 Terminology Relating to Roofing and Waterproofing](#)

[D3462 Specification for Asphalt Shingles Made from Glass Felt and Surfaced with Mineral Granules](#)

[D7158 Test Method for Wind Resistance of Asphalt Shingles \(Uplift Force/Uplift Resistance Method\)](#)

### 3. Terminology

3.1 *Definitions*—For definition of terms used in this test method, refer to Terminology [D1079](#).

3.2 *Definitions of Terms Specific to This Standard:*

---

<sup>1</sup> This test method is under the jurisdiction of ASTM Committee [D08](#) on Roofing and Waterproofing and is the direct responsibility of Subcommittee [D08.02](#) on Steep Roofing Products and Assemblies.

Current edition approved Dec. 1, 2008; Nov. 15, 2013. Published December 2008; November 2013. Originally approved in 1999. Last previous edition approved in 2003; 2008 as ~~D6381–03~~; ~~D6381–08~~. DOI: ~~10.1520/D6381-08~~; [10.1520/D6381\\_D6381M-08R13E01](#).

<sup>2</sup> For referenced ASTM standards, visit the ASTM website, [www.astm.org](http://www.astm.org), or contact ASTM Customer Service at [service@astm.org](mailto:service@astm.org). For *Annual Book of ASTM Standards* volume information, refer to the standard's Document Summary page on the ASTM website.

3.2.1 *seal*—as it relates to steep roofing shingles, is the bonding that results from the activation of the sealant under the action of time and temperature.

3.2.2 *sealant*—as it relates to steep roofing shingles, is defined as factory-applied or field-applied material designed to seal the shingles to each other under the action of time and temperature after the shingles are applied to a roof.

3.2.3 *sealed*—as it relates to steep roofing shingles, is the condition of the shingles after the sealant has been activated by the action of time and temperature.

#### 4. Summary of Test Method

4.1 The test specimens are constructed from pieces of shingles, overlaid and sealed prior to testing. All specimens are then conditioned and tested at selected temperatures. Specimens are tested in Procedure A by lifting the exposed edge and recording the uplift force required to break the seal, and in Procedure B, by recording the perpendicular force required to break the seal.

#### 5. Significance and Use

5.1 Uplift resistance is one of the properties of an applied shingle that relates to its ability to withstand wind forces. The mechanical tests described are laboratory methods to measure that resistance at a designated temperature after the shingles have been sealed under designated conditions.

5.1.1 No quantitative relationship has been established between the mechanical uplift resistance and uplift forces due to the wind.

5.2 Many factors influence the sealing characteristics of shingles in the field; for example, temperature, time, contamination by dirt and debris, roof slope, and interference by misplaced fasteners. It is not the objective of this test method to address all of these influences. This test method is designed to determine the mechanical uplift resistance when representative specimens of shingles are sealed under selected conditions prior to testing.

5.3 Procedure A produces lower results than Procedure B. Procedure A provides an edge-lift load value and Procedure B provides a perpendicular load value. The procedure applicable to a specific product depends on the specific product design, geometry, and rigidity. It is the responsibility of the user of this test method to determine the appropriate procedure with reference to the specific product and application. It is possible that engineering calculations would require both procedures to be employed, and for both results to be used in the calculation of the resistance of that specific product to the effects of wind.

5.4 When using this method in conjunction with Test Method D7158 to determine the uplift resistance of shingles as part of the determination of wind resistance of the shingles, determine the appropriate procedure (Procedure A, Procedure B, or both) in accordance with the discussion, and examples, of shingle geometry and sealant configuration in Section 12.2 of Test Method D7158.

#### 6. Apparatus

6.1 The *Tensile Testing Machine*, shall be a constant-rate-of-extension (CRE) type.

6.2 *Heavy-Duty Paper Cutter*, steel rule, die, or template 95 by 114 mm (3<sup>3</sup>/<sub>4</sub> by 4<sup>1</sup>/<sub>2</sub> in.) and 95 by 178 mm (3<sup>3</sup>/<sub>4</sub> by 7 in.) for Procedure A, and 102 by 152 mm (4 by 6 in.) and 95 by 38 mm (3<sup>3</sup>/<sub>4</sub> by 1<sup>1</sup>/<sub>2</sub> in.) for Procedure B.

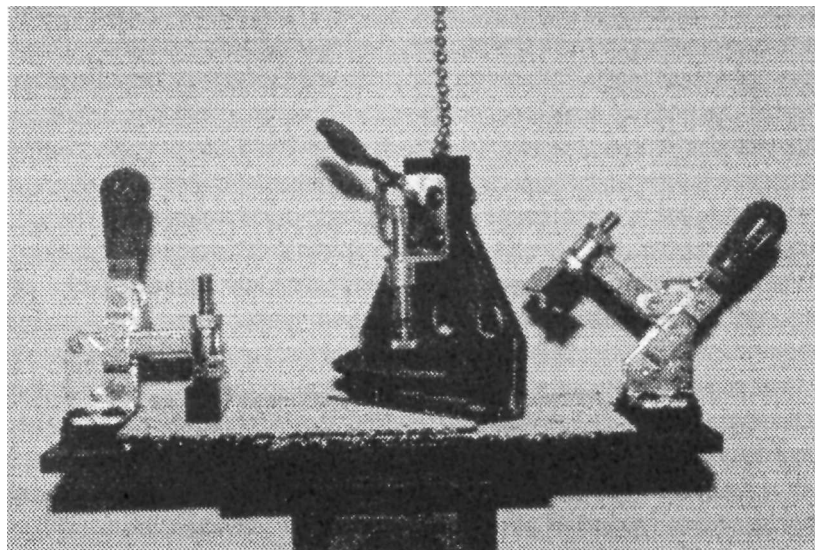

FIG. 1 Shingle Uplift Test Apparatus—Procedure A

6.3 *The Test Fixture for Procedure A* is a specially designed apparatus and drawings are on file at ASTM International Headquarters.<sup>3</sup> Fig. 1 is a photo of the apparatus in a typical tensile testing machine with a specimen in place.

6.4 *The Test Fixture for Procedure B* is identical to that used to determine Fastener Pull-Through Resistance in Specification D3462, except that a 3 mm ( $\frac{1}{8}$  in.)-thick aluminum mask 102 by 152 mm (4 by 6 in.) with a central opening 44 by 102 mm ( $1\frac{3}{4}$  by 4 in.) is used to restrain the specimen, and a 95 mm ( $3\frac{3}{4}$  in.) length of 38 mm ( $1\frac{1}{2}$  in.) aluminum “T” section is used to apply the perpendicular uplift force to the specimen. Two 127 mm (5 in.) equal lengths of chain form a bridle that is hooked into holes drilled in the web of the “T” section. Fig. 2 is a photo of the apparatus in a typical tensile testing machine with a specimen in place.

6.4.1 The two chains are suspended from a common closed S-hook that is pinned, but free to rotate, in the upper fixture of the test machine. Open S-hooks attached to the end of each chain are inserted into holes drilled 6 mm ( $\frac{1}{4}$  in.) from each end, and 13 mm ( $\frac{1}{2}$  in.) from the top, of the web of the “T” section. This arrangement of hooks and chains forms a free-swinging bridle that ensures perpendicular force application, and minimizes inducement of peeling forces, even when the test specimens are not uniformly sealed along their length.

6.5 *Temperature-Controlled Chamber*, to seal the specimens, capable of maintaining a temperature within  $\pm 1.5^\circ\text{C}$  ( $\pm 2.5^\circ\text{F}$ ) of the selected temperature. The sample tray shall be a rigid support large enough to hold specimens in the chamber.

6.6 *Temperature-Controlled Test Chamber*, capable of control within  $\pm 1.5^\circ\text{C}$  ( $\pm 2.5^\circ\text{F}$ ) which shall be used when testing the specimens at other than room temperature.

## 7. Specimen Preparation

7.1 Samples for testing shall be selected in accordance with the method specified in the sampling section of Test Methods D228. The test shall consist of ten specimens per test condition, as described in the following paragraphs.

<sup>3</sup> The sole source of supply of the apparatus known to the committee at this time is Ashcraft Machine and Supply Inc., 185 Wilson St., Newark, Ohio 43055. Specify Shingle Tab Uplift Tester, Model 102. If you are aware of alternative suppliers, please provide this information to ASTM International Headquarters. Your comments will receive careful consideration at a meeting of the responsible technical committee,<sup>1</sup> which you may attend.

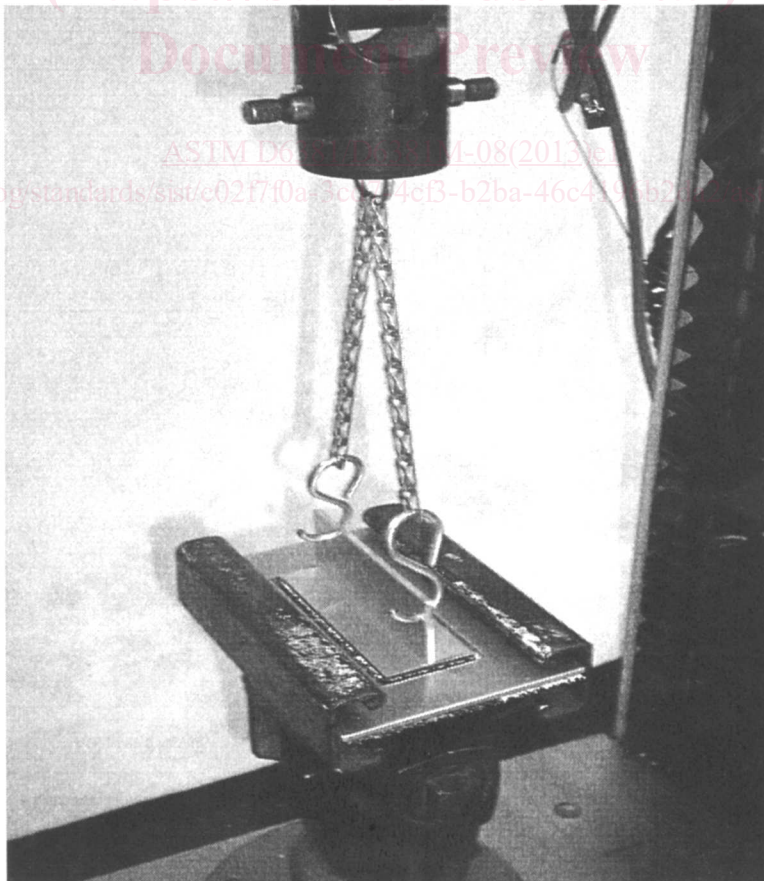

FIG. 2 Shingle Uplift Test Apparatus—Procedure B

7.2 Specimens taken from the sample of shingles shall be representative of the typical geometry (area), thickness (caliper), and contamination level (back surface particles, and so forth) of the adhesive in the lot of material being investigated.

7.3 When using Procedure A, insertion of the test apparatus can be a problem for cases where the sealant is brittle and weak or where it is applied close to the leading edge of the shingle. For these, and other such cases where normal insertion of the top clamp of the apparatus is a concern, an alternate technique of attaching to the top of the specimen is not prohibited (see 7.7.3).

7.4 The sealant present on the specimen to be tested shall be proportionally representative of the sealant present on the shingle when it is installed in the field. For example, if the linear coverage of the sealant geometry on a shingle using factory-applied sealant is 50 %, then the sealant shall cover 50 % of the width of the test specimen.

7.4.1 For a specimen representing field-applied sealant, for example, if the sealant is in a dot pattern then the same dot size and pattern shall be used on the laboratory-prepared specimen, following the manufacturer's application instructions.

7.5 In Procedure A, a specimen consists of a bottom piece 95 by 178 mm ( $3\frac{3}{4}$  by 7 in.) and a top piece 95 by 114 mm ( $3\frac{3}{4}$  by 4 $\frac{1}{2}$  in.); both cut from one shingle as shown in Fig. 3a for single-layer shingles or Fig. 3b for multi-layer shingles. For multi-layer shingles that do not have a single-layer area from which to cut the top piece, cut the top piece at the point of the fewest layers. Longer or shorter specimens are not prohibited provided both clamps secure the specimen when it is aligned in the test fixture. The length of the specimens shall be determined for proper alignment in the fixture. Dimensional tolerances are  $\pm 3$  mm ( $\pm \frac{1}{8}$  in.) on the width of the specimen.

7.6 In Procedure B, a specimen consists of a bottom piece 102 by 152 mm (4 by 6 in.) and a top piece 38 by 95 mm (1 $\frac{1}{2}$  by 3 $\frac{3}{4}$  in.) both cut from one shingle as shown in Fig. 3a for single-layer shingles, or Fig. 3b for multi-layer shingles. For multi-layer shingles that do not have a single-layer top piece, cut the top piece at the point of the fewest layers. Dimensional tolerances are  $\pm 3$  mm ( $\pm \frac{1}{8}$  in.) on the width and length of the specimen.

7.7 In Procedure A, lay the top piece over the bottom piece, as shown in Figs. 4a and 4b, and in a manner representative of the actual alignment as specified in the shingle manufacturer's application instructions.

7.7.1 Not all multi-layer shingles have the sealant in the same location on the shingle. Whether the sealant is on the top of the bottom piece, or on the bottom of the top piece, the "A" dimension in Procedure A is determined by measuring the distance from the leading edge of the sealant to the leading edge of the top piece when the sample pieces are correctly positioned (in accordance with 7.7). In the case where the sealant is on the back of the top piece, the bottom piece shall be cut so that when the top piece is correctly positioned on the bottom piece, the sealant is in contact with the lower shingle in the same area of the surface it would contact when correctly installed on a roof in accordance with the manufacturer's instructions. The critical dimension in Procedure A is the distance the top piece overlaps the sealant on the bottom piece (denoted A in Figs. 4a and 4b). This dimension shall be equal to the overlap in the specified application.

7.7.2 Position the specimens on the tray without overlapping or stacking of the individual specimens.

7.7.3 For cases when an alternate top attachment method is desired (see 7.3) a special metal connector<sup>4</sup> shall be epoxy-bonded to the top piece of the specimen following sealant bonding and prior to conditioning and testing. This metal connector shall be equal to the width of the specimen. It shall be positioned at the edge of the top piece and bonded to adequately attach to the top of the specimen to facilitate insertion of the test fixture. A photo of the connector, attached to a test specimen, is shown in Fig. 5. The top clamp assembly attached to this connector is shown in Fig. 6.

7.8 In Procedure B, lay the top piece centered over the bottom piece as shown in Fig. 7a. The pieces are cut such that the sealant material is centered on the long axis of the rectangular piece, and is either on the weather surface of the bottom piece or the bottom surface of the top piece depending on the shingle design.

7.8.1 It is not possible to anticipate all potential shingle variations such as shape, number of layers, position, geometry, and nature of sealant, and so forth. Provided that the principle of Procedure B, the geometry of the specimen pieces, and the central location of the sealant in the specimen in the test fixture is satisfied, it is not prohibited to use two pieces of shingle butted together to satisfy the requirements. When this is done, it shall be stated in the report (see 11.1.5).

## 8. Calibration and Standardization

### 8.1 CRE Tensile Tester:

8.1.1 Set up the testing machine with the test fixture in place with the following operating parameters:

8.1.1.1 *Crosshead Speed*—2 mm/s (5 in./min), [5 in./min], and

8.1.1.2 *Gage Length*—Set to accommodate the test fixture without putting any strain on the sealant joint.

8.1.2 In Procedure A, zero the tester with the top clamp assembly in place hanging freely.

8.1.3 In Procedure B, zero the tester with the chain bridle, the hooks, and the "T" section with a typical top piece of specimen glued in place, hanging freely to "tare" the apparatus (without bottom piece and mask).

<sup>4</sup> The sole source of supply of the apparatus known to the committee at this time is Ashcraft Machine and Supply, 185 Wilson St., Newark, Ohio 43055, and specified on the drawings for the apparatus. If you are aware of alternative suppliers, please provide this information to ASTM International Headquarters. Your comments will receive careful consideration at a meeting of the responsible technical committee<sup>1</sup>, which you may attend.

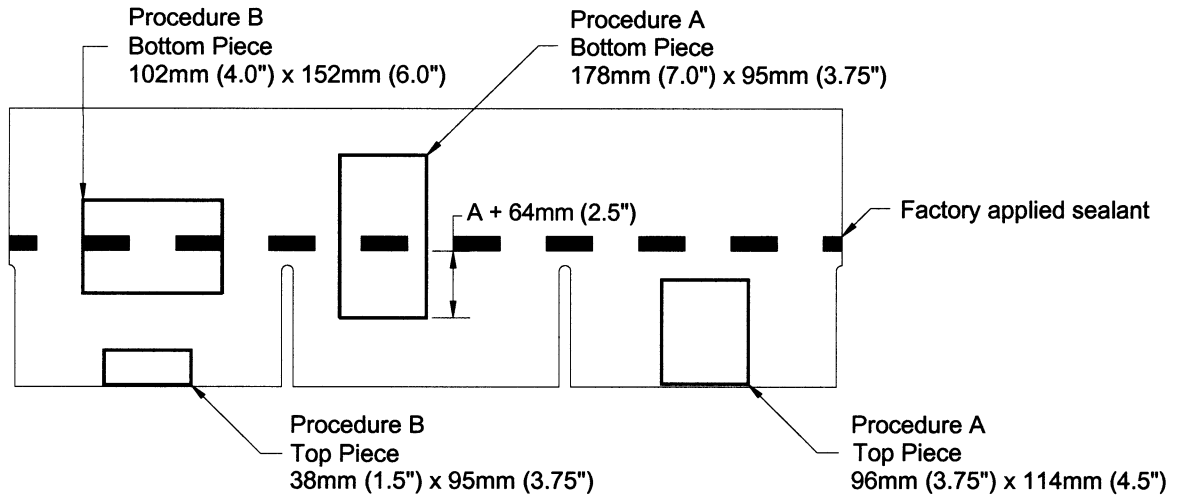

Dimensional Tolerances  $\pm 3\text{mm}$  (0.125")  
Not to scale

FIG. 3a Plan View of Shingle-Layer Shingle Showing Typical Specimen Locations

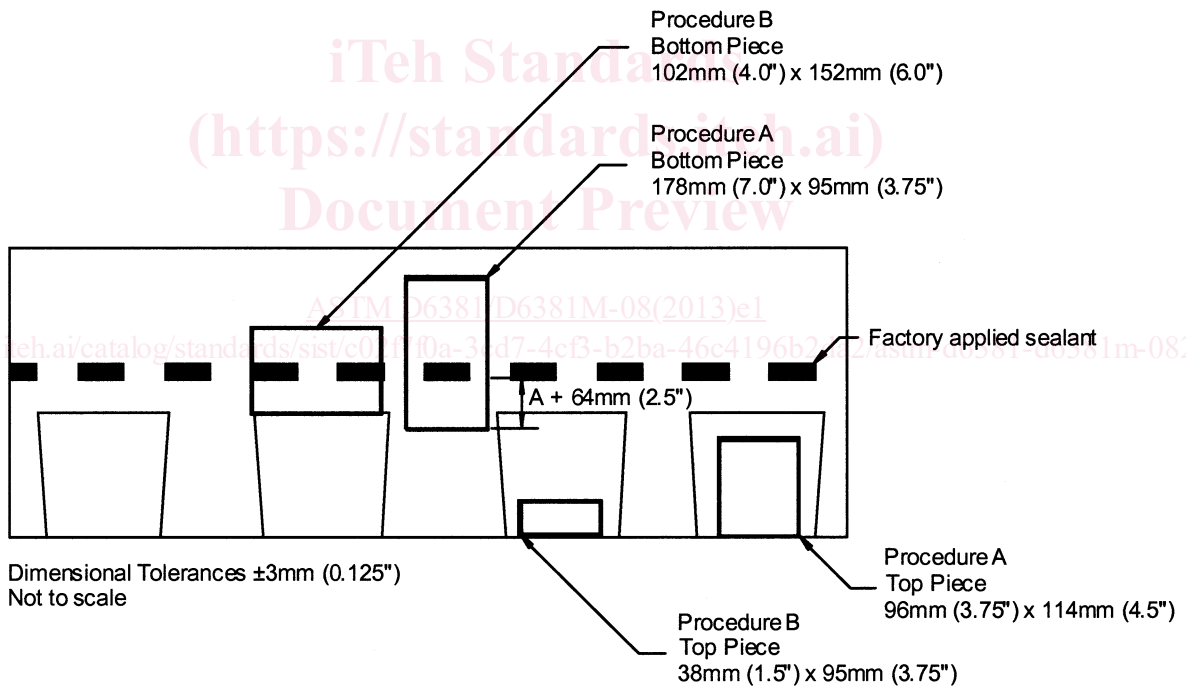

Dimensional Tolerances  $\pm 3\text{mm}$  (0.125")  
Not to scale

FIG. 3b Plan View of Multi-Layer Shingle Showing Typical Specimen Locations

FIG. 3 Plan View Showing Typical Specimen Locations

## 9. Sealing and Conditioning

9.1 Seal the specimens on a sample tray, oriented horizontally, at the designated temperature,  $\pm 1.5^\circ\text{C}$  ( $\pm 2.5^\circ\text{F}$ ) [ $\pm 2.5^\circ\text{F}$ ] for the desired time,  $\pm 2\%$ .

9.2 Without disturbing the specimen arrangement, after sealing, condition the specimens at the desired test temperature,  $\pm 1.5^\circ\text{C}$  ( $\pm 2.5^\circ\text{F}$ ); [ $\pm 2.5^\circ\text{F}$ ], for at least 1 h.

9.2.1 In Procedure B, the "T"-section is adhered after sealing the specimens and before conditioning.

## 10. Procedure

10.1 *Procedure A:*

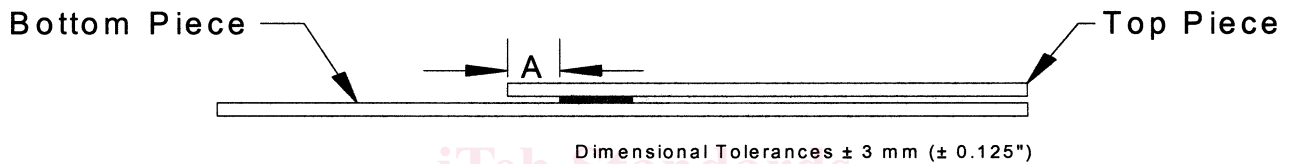
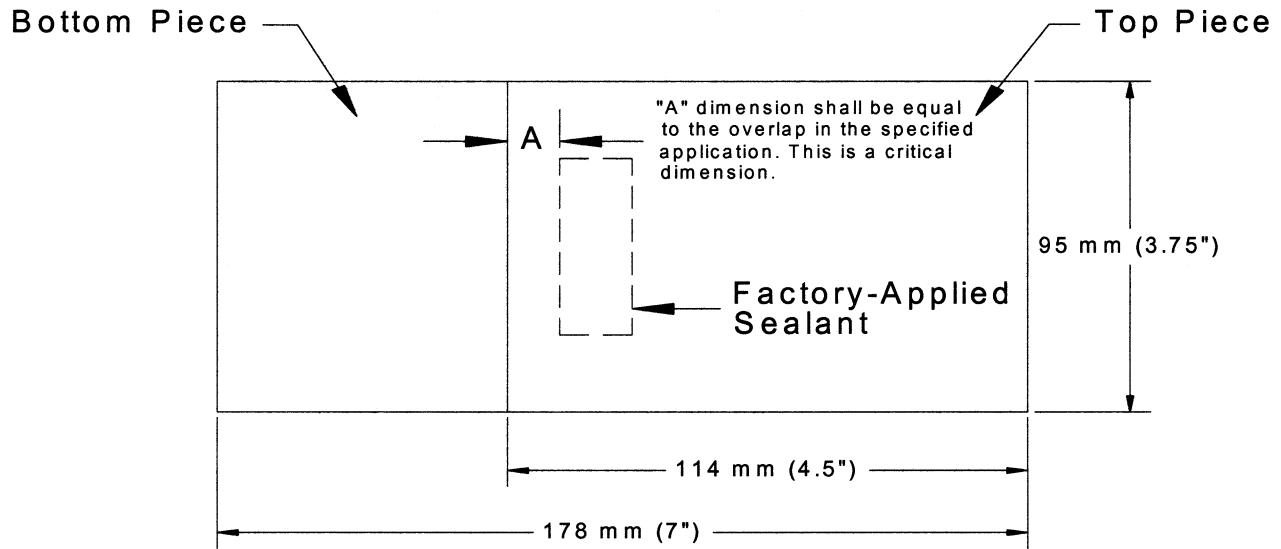

FIG. 4a Top and Side View of Test Specimen—Procedure A

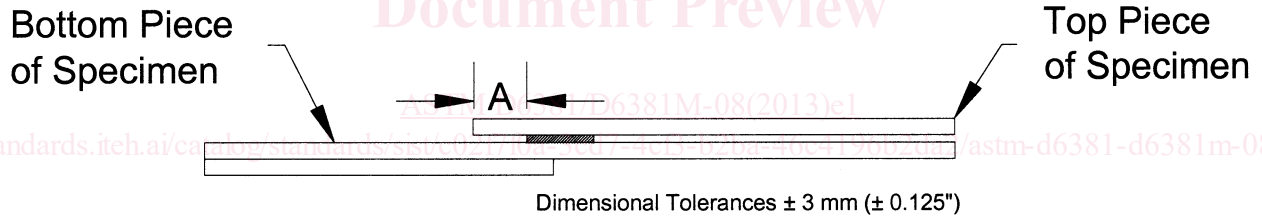

FIG. 4b Side View of Multi-Layer Test Specimen—Procedure A

FIG. 4 Top and Side Views of Test Specimen—Procedure A

10.1.1 Open both clamps and carefully slide the conditioned specimen into the test fixture. Align the specimens so that the sealant centerline corresponds to the vertical centerline of the test apparatus and centered in the fixture in both directions. Exercise care in positioning specimens in the test fixture to avoid disturbing the temperature of the specimens or the nature of the seal.

10.1.2 Position the top clamp assembly under the top overlap, using the thumb to operate the clamp. Close the clamps to secure the specimen. Operate the tensile tester and record maximum force to the nearest 1.0 N (0.2 lbf) [0.2 lbf].

10.1.3 Repeat 10.1.1 and 10.1.2 for the remaining specimens.

10.1.4 When the sealant bond breaks in the course of attaching the top clamp to the overlap piece, this specimen is counted and entered as a zero value. A specimen that is mishandled, such as being dropped or inadvertently twisted in handling, shall be replaced with another sealed and conditioned specimen.

10.2 Procedure B:

10.2.1 Attach the flat surface of the inverted aluminum “T” section to the top surface of the top piece using a suitable adhesive applied to the entire area of the flat surface of the “T” (epoxy and urethane adhesives have been found suitable). The flat surface of the “T” shall be coincident with the top surface of the top piece (the two surfaces are the same size). Take care not to disturb the sealed specimen by floating the “T” section on the fluid adhesive, and also to assure that the web of the “T” section is as close as possible to being perpendicular to the plane of the shingle.