



Designation: F711 – 02 (Reapproved 2013)

Standard Specification for Fiberglass-Reinforced Plastic (FRP) Rod and Tube Used in Live Line Tools¹

This standard is issued under the fixed designation F711; the number immediately following the designation indicates the year of original adoption or, in the case of revision, the year of last revision. A number in parentheses indicates the year of last reapproval. A superscript epsilon (ϵ) indicates an editorial change since the last revision or reapproval.

1. Scope

1.1 This specification covers insulating rods and foam-filled tubes made from fiberglass-reinforced plastic (FRP) that are intended for use in live line tools.

1.2 This specification does not include insulating foam-filled tubes and rods from other materials. Specifications for fittings and attachments to rods and foam-filled tubes for complete tools are not covered in this specification.

1.3 This specification establishes the technical characteristics that the tubes and rods must satisfy.

1.4 The following safety hazards caveat pertains only to the test method portion, Section 12, of this specification. *This standard does not purport to address all of the safety concerns, if any, associated with its use. It is the responsibility of the user of this standard to establish appropriate safety and health practices and determine the applicability of regulatory limitations prior to use.*

2. Referenced Documents

2.1 *ASTM Standards:*²

D149 Test Method for Dielectric Breakdown Voltage and Dielectric Strength of Solid Electrical Insulating Materials at Commercial Power Frequencies

D638 Test Method for Tensile Properties of Plastics

D695 Test Method for Compressive Properties of Rigid Plastics

3. Terminology

3.1 *Definitions of Terms Specific to This Standard:*

3.1.1 *acceptance test*—a type of test made at the option of the purchaser.

¹ This specification is under the jurisdiction of ASTM Committee F18 on Electrical Protective Equipment for Workers and is the direct responsibility of Subcommittee F18.35 on Tools & Equipment.

Current edition approved Nov. 1, 2013. Published December 2013. Originally approved in 1981. Last previous edition approved in 2007 as F711 – 02(2007). DOI: 10.1520/F0711-02R13.

² For referenced ASTM standards, visit the ASTM website, www.astm.org, or contact ASTM Customer Service at service@astm.org. For *Annual Book of ASTM Standards* volume information, refer to the standard's Document Summary page on the ASTM website.

3.1.2 *design test*—a type of test made on a sample treated as representative of an industrial product. These tests will not generally be repeated in quantity production.

3.1.3 *insulating tubes and rods*—fiberglass-reinforced plastic (FRP) products manufactured using processes so that the tubes and rods produced will meet the electrical and mechanical tests prescribed in this specification.

3.1.4 *interior foam-filled tube*—homogeneous unicellular thermosetting foam filling with closed cells blown with non-combustible gases. The foam filling shall be bonded to the interior tube wall. The foam filling should be free of voids, separations, holes, cracks, etc.

3.1.5 *routine test*—a type of test made regularly on production material.

3.1.6 *visual inspection*—a visual check made to detect constructional defects.

4. Ordering Information

4.1 *Outside Diameter Sizes*—Foam-filled FRP tube and solid FRP rod shall meet the outside diameter dimensions shown in Table 1. The tolerances shown will assist in ensuring interchangeability with interfacing equipment.

4.2 Inspection of the material shall be agreed upon between the purchaser and the seller as part of the purchase contract.

5. Materials and Manufacture

5.1 Except for those test methods leading to destruction, neither the FRP tube, foam, or the bond between them shall deteriorate during the prescribed mechanical and electrical tests of this specification.

6. Physical Requirements

6.1 The materials shall conform to the diameters prescribed in Table 1 for tube and rod.

6.2 The standard sizes listed by nominal diameter are recommended and do not preclude the manufacture of other sizes or shapes.

7. Weight

7.1 It has not been found necessary to specify the weight of the product produced under this specification in order for it to comply with performance requirements.

TABLE 1 Standard Tube and Rod Outside Diameters

TYPE	Nominal Diameter		Min Diameter		Max Diameter	
	in.	(mm)	in.	(mm)	in.	(mm)
Tube	1	(25.4)	0.98	(24.9)	1.02	(25.9)
	1¼	(31.8)	1.22	(31.0)	1.27	(32.3)
	1½	(38.1)	1.47	(37.3)	1.53	(38.9)
	1¾	(44.5)	1.73	(43.9)	1.78	(45.2)
	2	(50.8)	1.97	(50.0)	2.04	(51.8)
	2½	(63.5)	2.47	(62.7)	2.54	(64.5)
Rod	3	(76.2)	2.97	(75.3)	3.04	(77.2)
	¾	(9.5)	0.369	(9.4)	0.385	(9.8)
	½	(12.7)	0.490	(12.4)	0.510	(13.0)
	⅝	(15.9)	0.610	(15.5)	0.635	(16.1)
	¾	(19.1)	0.720	(18.3)	0.765	(19.4)

8. Workmanship, Finish, and Appearance

8.1 The external surface shall be uniform, symmetrical, and free of abrasions, scratches, blemishes, and surface defects.

8.2 Any defect that may capture an impurity or impair the dielectric integrity of the product shall be cause for rejection.

8.3 FRP rod or tube material after which a finish coating, such as paint, is applied must meet all physical, electrical, and mechanical requirements.

9. Sampling

9.1 Design Test—Perform the test on a minimum of three samples only when changes are made to a new or existing design of the product that may affect the mechanical and electrical characteristics.

9.1.1 The design test will be used to qualify a specific item and normally will not be repeated during production.

9.2 Sample Test—A test specimen shall consist of one or more items, dependent on 1 % of the lot being tested.

9.2.1 A lot is represented either by all items produced in one production run or in one shipment.

9.2.2 Lots of new, unused items shall have test specimens selected at random.

9.3 Routine Test—Perform the test on all pieces delivered to the purchaser.

9.4 Acceptance Test—A test made at the option of the purchaser.

10. Conduct of Tests on Samples

10.1 Mechanical:

Test	Type	Material
Wicking	design	tube
Bending deflection	design	tube
Horizontal crush	design	tube
Tension	acceptance	tube
	design	tube
Shear	design	rod
Compression	design	rod
Modulus of elasticity (tension)	design	rod
Mechanical aging (flexure)	design	tube
	design	rod
Visual	design	tube
	design	rod
Dimensional	acceptance	tube
	acceptance	rod
	acceptance	tube

routine
routine

tube
rod

10.2 Electrical:

Test	Type	Material
Dielectric current (leakage) (before moisture conditioning)	design	rod
Dielectric current (leakage) (after moisture conditioning)	design	tube
Withstand (either method 1 or 2)	design	rod
	routine	tube

11. Number of Tests and Samples (Three each)

11.1 Tubes:

11.1.1 Wicking Test—Three samples, each 1-in. (25-mm) long.

11.1.2 Bending Deflection Test—8 ft, 5 in. (2.6 m) or longer. See Fig. 13.

11.1.3 Horizontal Crush Test—Three diameters long. See Fig. 14.

11.1.4 Tension Test—12-in. (300-mm) long, prepared in accordance with Fig. 1 and Test Method D638.

11.1.5 Shear Test—4-in. (100-mm) long, prepared in accordance with Fig. 2.

11.1.6 Electrical Tests—12-in. (300-mm) long, prepared in accordance with Section 12.

11.2 Rod:

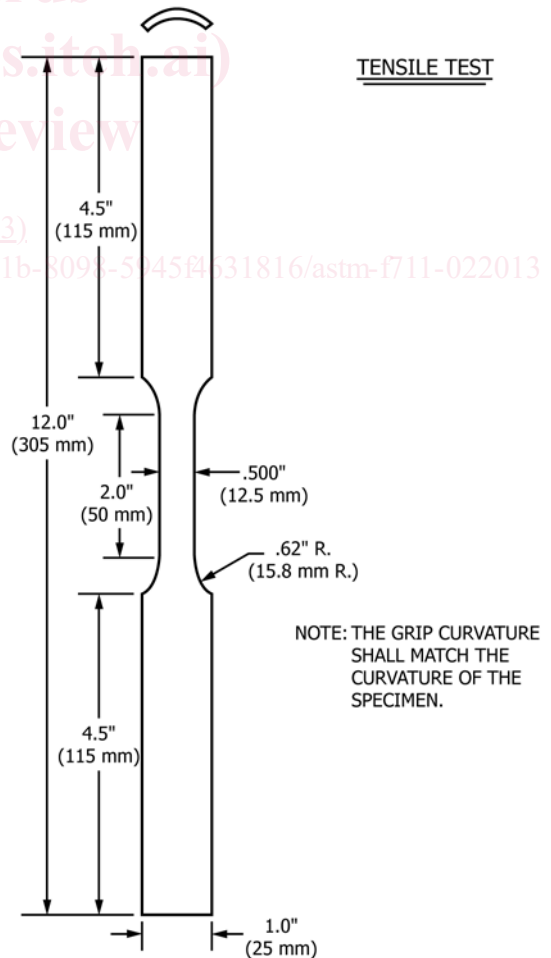

FIG. 1 Tension Test

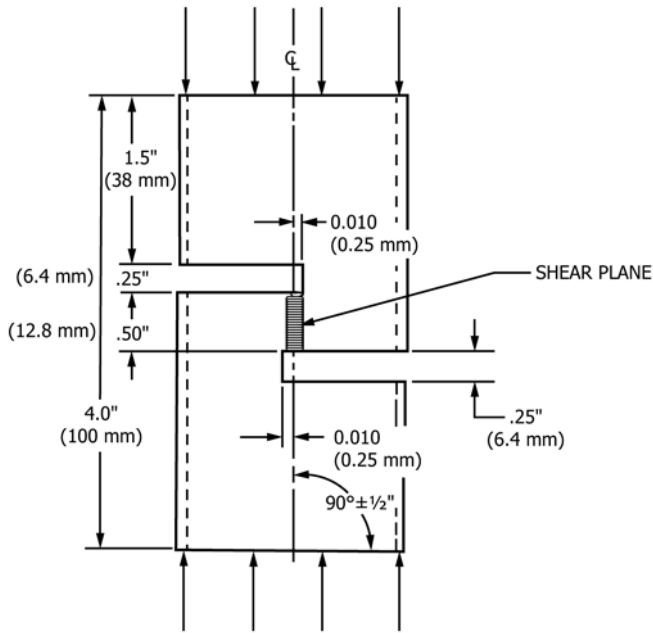

FIG. 2 Shear Test

12. Test Methods

12.1 *Visual Inspection*—Make a visual check to detect manufacturing defects (for example, evidence of faulty bonding between fibers and resin, air bubbles, foreign bodies, or particles).

12.2 *Electrical Tests*—The test apparatus shall be designed to provide the operator full protection in the performance of his duties and provide reliable means of de-energizing and grounding the high voltage circuit.

12.2.1 During the course of the testing, there shall be no sign of flashover or puncture on any of the samples.

12.2.2 The ambient temperature for the test location shall not be lower than 60°F (16°C).

12.2.3 Prior to the first or initial electrical test, the sample shall be cleaned with a suitable solvent as recommended by the manufacturer (specifically a solvent that neither destroys the materials from which the tube or rod is made nor leaves any residue on the surface of the sample).

12.2.3.1 After initial cleaning, the sample shall remain in the ambient atmosphere of the test premises for at least 24 h.

12.2.4 *Electrical Design Test*—The sample for the dielectric test shall be 12 in. (300 mm) in length.

12.2.4.1 The electrical design tests shall be made before and after exposure to moisture conditions, as specified, using 60-Hz voltage.

12.2.4.2 A typical test setup is shown in Fig. 3. Details are shown in Figs. 4-9. The measuring equipment should not be less than 6 ft (1.8 m) from the high-voltage electrode. Shield and ground the assembly for the measuring equipment. Vertically mount the test specimen at least 3 ft (0.9 m) above the floor on an insulating support. Apply the voltage of 100 kV rms at 60 Hz between the electrodes, in accordance with Test Method D149 at a maximum voltage rise of 3000 V/s. Measure

11.2.1 *Compression Test* (Applicable to solid rod only)—4-ft (1.2-m) long, prepared in accordance with Test Method D695.

11.2.2 *Modulus of Elasticity (Tension)* (Applicable to solid rod only)—4 ft (1.2 m) long, prepared in accordance with Test Method D638.

11.3 *Rod and Tube Mechanical Aging Tests:*

11.3.1 *Flexure*—Rod, 4 ft (1.2 m) or tube, 8 ft (2.4 m) in length.

ASTM F711-02

<https://standards.iteh.ai/catalog/standards/sist/b1d4f5ef-9141-411b-8098-5945f4631816/astm-f711-022013>

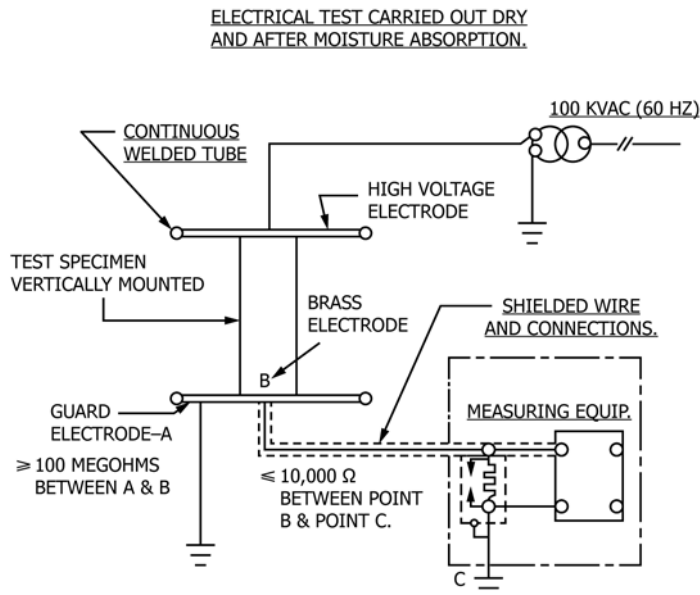

ELECTRICAL TEST CARRIED OUT DRY AND AFTER MOISTURE ABSORPTION.

NOTE 1—For details of Fig. 3 see Figs. 4-9.

FIG. 3 Typical AC Test Set Up

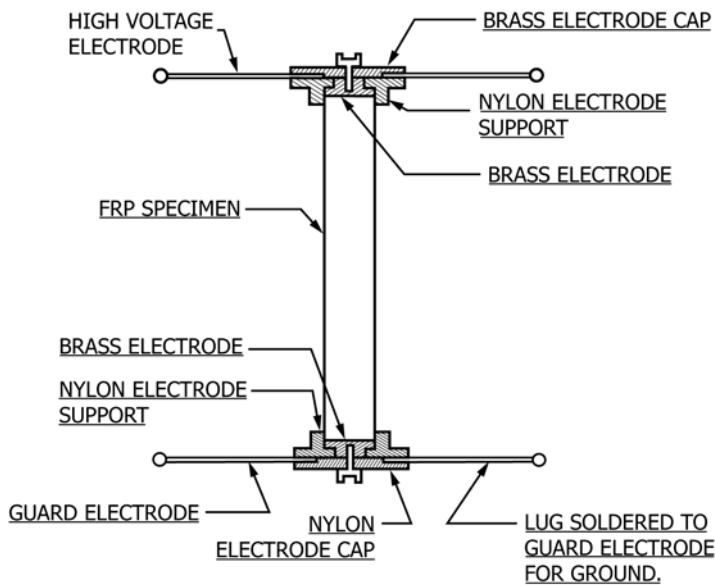
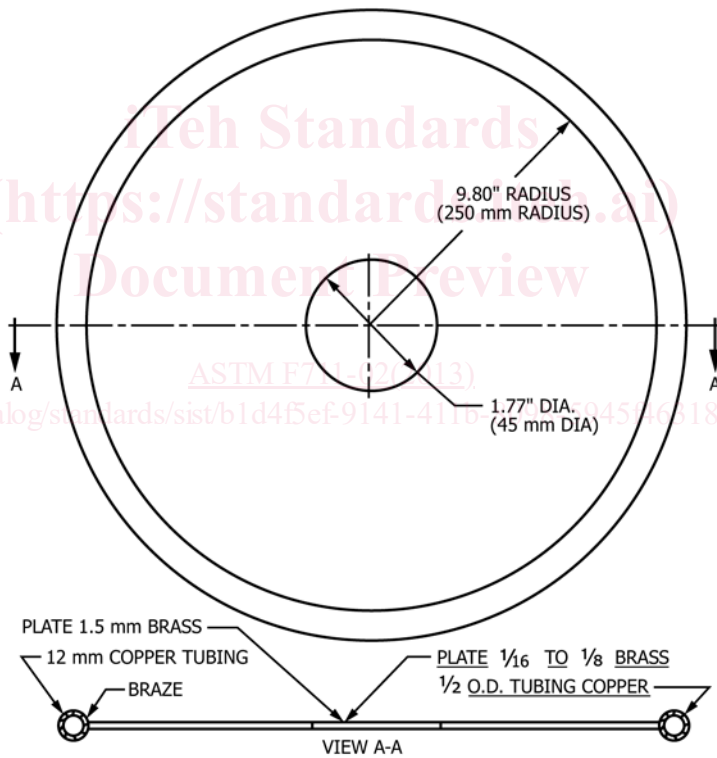

FIG. 4 Assembly Detail



2 REQUIRED

FIG. 5 Electrode Detail

the current passing over or through the test specimen in rms values by passing it through a known resistance.

(a) The current I_1 is the maximum dielectric current measured with an alternating voltage of 100 kV rms 60 Hz applied between the electrodes for 1 min.

(b) Upon completion of the before-moisture conditioning electrical test (I_1), the sample shall then be placed in a suitable chamber and undergo the following conditioning prior to the after-moisture conditioning electrical test, (I_2).