



Designation: G182 – 13

# Standard Test Method for Determination of the Breakaway Friction Characteristics of Rolling Element Bearings<sup>1</sup>

This standard is issued under the fixed designation G182; the number immediately following the designation indicates the year of original adoption or, in the case of revision, the year of last revision. A number in parentheses indicates the year of last reapproval. A superscript epsilon ( $\epsilon$ ) indicates an editorial change since the last revision or reapproval.

## 1. Scope

1.1 This test method is an extension of Test Method G164 and uses an inclined plane and a paperclip rider to detect the presence or absence of lubricants on the surfaces of flexible webs. A study to identify free spinning or low rolling friction bearings indicated that the paperclip friction test could be used for rolling friction by simply replacing the paperclip with a rolling element bearing on an axle. The angle of the inclined plane at initiation of rolling is the breakaway angle. This test method can be used to measure the angle at breakaway of small diameter (up to 100 mm outside diameter) rolling element bearings. The bearings that have been tested in the development of this method are conventional ball bearings with different separators, seals, and different conditions of lubrication (none, oil, greases, and so forth), but there is no technical reason why this test method would not work with bearings of other design, including plain bearings. Rolling element bearings like any sliding system can have friction characteristics at breakaway that are different than rolling continuously. As is the case with most inclined plane friction tests, the test only produces the friction characteristic at the onset of measurable rolling, using the angle ( $\theta$ ) when measurable rolling commences. The objective of this test is an assessment of breakaway rolling friction characteristics to assist machine designers in the selection of rolling element bearings for instrument pivots and the like where breakaway friction is a concern.

1.2 The values stated in SI units are to be regarded as standard. No other units of measurement are included in this standard.

1.3 *This standard does not purport to address all of the safety concerns, if any, associated with its use. It is the responsibility of the user of this standard to establish appropriate safety and health practices and determine the applicability of regulatory limitations prior to use.*

<sup>1</sup> This test method is under the jurisdiction of ASTM Committee G02 on Wear and Erosion and is the direct responsibility of Subcommittee G02.50 on Friction.

Current edition approved Nov. 15, 2013. Published December 2013. Originally approved in 2006. Last previous edition approved in 2006 as G182 – 06. DOI: 10.1520/G0182-13.

## 2. Referenced Documents

### 2.1 ASTM Standards:<sup>2</sup>

G40 Terminology Relating to Wear and Erosion

G117 Guide for Calculating and Reporting Measures of Precision Using Data from Interlaboratory Wear or Erosion Tests

G143 Test Method for Measurement of Web/Roller Friction Characteristics

G164 Test Method for Determination of Surface Lubrication on Flexible Webs

## 3. Terminology

3.1 *Definitions Relating to Wear and Erosion (taken from Terminology G40):*

3.1.1 *coefficient of friction,  $\mu$* —in tribology, the dimensionless ratio of the friction force ( $F$ ) between two bodies to the normal force ( $N$ ) pressing these bodies together.

3.1.2 *friction force*—the resisting force tangential to the interface between two bodies when, under the action of external force, one body moves or tends to move relative to the other.

3.1.3 *kinetic coefficient of friction*—the coefficient of friction under conditions of macroscopic relative motion between two bodies.

3.1.4 *lubricant*—any substance interposed between two surfaces for the purpose of reducing the friction and wear between them.

### 3.2 Definitions Not Covered by Terminology G40:

3.2.1 *breakaway coefficient of rolling friction*—the force in the direction of rolling ( $F$ ) required to produce rolling of a shape that is capable of rolling on a surface, divided by the normal force ( $N$ ) on the rolling shape:

$$\mu_{\text{rolling}} = \frac{F}{N} \quad (1)$$

3.2.2 *inclined plane*—a surface that can be raised at an angle to produce motion of an object on the plane.

<sup>2</sup> For referenced ASTM standards, visit the ASTM website, www.astm.org, or contact ASTM Customer Service at service@astm.org. For *Annual Book of ASTM Standards* volume information, refer to the standard's Document Summary page on the ASTM website.

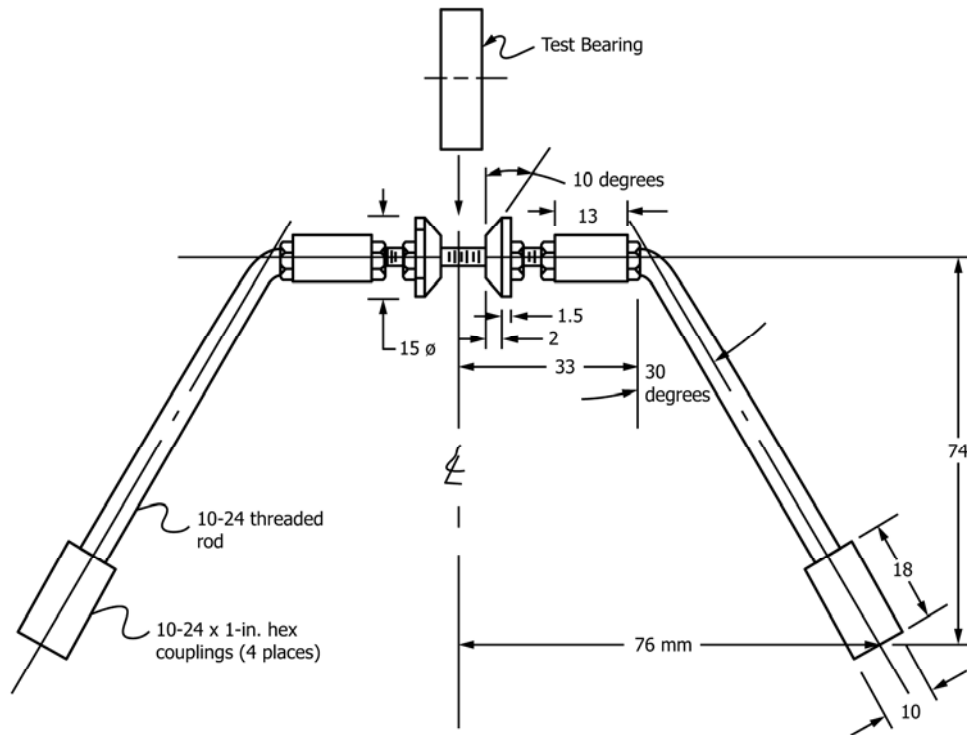

NOTE 1—User must determine weight and center of gravity. All components to be made from brass or steel.

FIG. 1 Suggested Balancing Arm

3.2.3 *plain bearings*—a cylindrical shape used to support a rotating shaft.

3.2.4 *rolling element bearing*—balls or rollers in raceways that support a shaft and allow rotation of the shaft or bearing outer race (OD).

#### 4. Summary of Test Method

4.1 This test method can be used to measure the breakaway rolling friction characteristics of rolling element bearings.

4.2 Small rolling element bearings (less than 100 mm outside diameter) are affixed to a balanced rider and placed on an incline. The rider is designed so that it becomes the axle about which the bearing rotates. The inclined plane is raised (by hand or mechanism) until the outer race (OD) of the bearing starts to roll on the inclined plane. The inclined plane surface is covered with a plasticized PVC tape to increase the static friction between the outside surface of the bearing and inclined plane. The test will not yield rolling friction characteristics if the bearing slides rather than rolls on the inclined plane.

4.3 The rolling friction characteristics measured by this test are the net result of the bearing design, materials and state of lubrication. Thus this test could also be used to evaluate bearing designs and bearing greases.

#### 5. Significance and Use

5.1 This test is a simple, effective way of determining the ability of bearings to roll freely. Most bearing manufacturers do not supply information on the breakaway friction coefficient of their products and if this is a design factor, users often buy

candidate bearings and try them until they find one that appears to operate freer than the others. This test allows quantification of the breakaway friction characteristics of bearings. This test assesses the friction of a bearing as a tribosystem which includes its construction and lubrication. It has shown to correlate with use. If a bearing has a low breakaway angle in this test, its breakaway friction will be lower in service than the same size bearings that displayed a higher breakaway angle in this test.

5.2 Breakaway friction of bearings is important in instruments where forces are light and the bearings are used as pivots rather than for continued rotation. Low friction is often imperative for proper device operation.

5.3 Bearings with low breakaway friction are often sought for web handling rollers. Many rollers are driven only by tangential web contact and slippage can often damage the web. Low friction bearings are required.

5.4 This test is useful for screening bearings for any applications where breakaway friction is a design concern.

#### 6. Apparatus

6.1 *Bearing Axle*—The test bearing is clamped between two tapered plugs assembled on the threaded-rod rider shown in Fig. 1. The tapered plugs are tightened such that the inner race of the bearing is fixed to and centered on the horizontal portion of the threaded rod.

6.2 *Weights*—The normal force of the bearing on the inclined plane is produced by the cumulative mass of the bearing and the rider assembly that holds the bearing. The weight of the