



Designation: F510/F510M – 13

## Standard Test Method for Resistance to Abrasion of Resilient Floor Coverings Using an Abrader with a Grit Feed Method<sup>1</sup>

This standard is issued under the fixed designation F510/F510M; the number immediately following the designation indicates the year of original adoption or, in the case of revision, the year of last revision. A number in parentheses indicates the year of last reapproval. A superscript epsilon ( $\epsilon$ ) indicates an editorial change since the last revision or reapproval.

*This standard has been approved for use by agencies of the Department of Defense.*

### 1. Scope

1.1 This test method<sup>2</sup> describes a laboratory procedure for determining the abrasion resistance of resilient flooring using an abrader with a grit feeder.<sup>3</sup>

1.2 The equipment used in this test method is a modification of the Taber abraser. The regular abrading wheels are replaced by leather clad brass wheels (rollers). As the specimen holder rotates, a grit-feeding device feeds 240-mesh aluminum oxide grit onto the specimen before it passes under the leather clad brass wheels. Using the vacuum system incorporated in the apparatus, the used grit and abraded material are removed after passing under both wheels.

1.3 This test method employs a rotary, rubbing action caused by loose abrasive grit and the two abrading wheels. One wheel rubs the specimen from the center outward and the other from the outside toward the center. The wheels traverse a complete circle and have an abrasive action on the rotating specimen at all angles. This action approaches the twisting action between shoe and floor that occurs when a person turns. The use of loose grit serves the function of an abradant and also aids in the rolling action characteristic of normal walking.

1.4 The values stated in either SI units or inch-pound units are to be regarded separately as standard. The values stated in each system may not be exact equivalents; therefore, each system shall be used independently of the other. Combining values from the two systems may result in non-conformance with the standard.

1.5 *This standard does not purport to address all of the safety concerns, if any, associated with its use. It is the*

*responsibility of the user of this standard to establish appropriate safety and health practices and determine the applicability of regulatory limitations prior to use.*

### 2. Referenced Documents

#### 2.1 ASTM Standards:<sup>4</sup>

D1860 Test Method for Moisture and Creosote-Type Preservative in Wood (Withdrawn 2006)<sup>5</sup>

D792 Test Methods for Density and Specific Gravity (Relative Density) of Plastics by Displacement

E122 Practice for Calculating Sample Size to Estimate, With Specified Precision, the Average for a Characteristic of a Lot or Process

G195 Guide for Conducting Wear Tests Using a Rotary Platform Abraser

#### 2.2 ANSI Standard:

B74.12 Checking the Size of Abrasive Grain for Grinding Wheels, Polishing, and General Industrial Uses<sup>6</sup>

### 3. Terminology

#### 3.1 Definitions:

3.1.1 *abrasion*—of resilient floor coverings, a form of wear, in which a gradual removing of a flooring surface is caused by the frictional action of relatively fine hard particles.

3.1.2 *resistance to abrasion*— of resilient floor coverings, the ability of a material to withstand mechanical actions of relatively fine hard particles, which by rubbing, scraping, and eroding remove material from a floor covering surface.

### 4. Significance and Use

4.1 When subjected to normal in-use traffic conditions, a flooring material is exposed to abrasion caused by the destructive action of fine hard particles. This situation occurs whenever loose debris, dirt and other particulate matter exists

<sup>1</sup> This test method is under the jurisdiction of ASTM Committee F06 on Resilient Floor Coverings and is the direct responsibility of Subcommittee F06.30 on Test Methods - Performance.

Current edition approved Nov. 1, 2013. Published December 2013. Originally approved in 1978. Last previous edition approved in 2008 as F510-93(2008). DOI: 10.1520/F0510\_F0510M-13.

<sup>2</sup> This test method is described by W. E. Irwin in "Development of a Method to Measure Wear on Resilient Flooring," *Journal of Testing and Evaluation*, Vol 4, No. 1, January 1976, pp. 15-20.

<sup>3</sup> This grit feed method is frequently referred to as the "Frick Grit Feed Method" because it is based on work done by Otto F. V. Frick as described in "Studies of Wear on Flooring Materials," *Wear*, Vol 14, 1969, pp. 119-131.

<sup>4</sup> For referenced ASTM standards, visit the ASTM website, [www.astm.org](http://www.astm.org), or contact ASTM Customer Service at [service@astm.org](mailto:service@astm.org). For *Annual Book of ASTM Standards* volume information, refer to the standard's Document Summary page on the ASTM website.

<sup>5</sup> The last approved version of this historical standard is referenced on [www.astm.org](http://www.astm.org).

<sup>6</sup> Available from American National Standards Institute, 25 West 43rd St., 4th Floor, New York, NY 10036.



FIG. 1 Taber Abraser with Grit Feeder

4.3 This test method is designed to simulate one kind of abrasive action and abradant that a flooring may encounter in the field. However, results should not be used as an absolute index of ultimate life because, as noted, there are too many factors and interactions to consider. Also involved are the many different types of service locations. Therefore, the data from this test method are of value chiefly in the development of materials and should not be used without qualifications as a basis for commercial comparisons.

5. Apparatus

5.1 Apparatus<sup>7</sup>, as shown in Fig. 1, shall consist of the following:

5.1.1 Abraser, as described in Guide G195.

5.1.2 S-39 Leather-covered brass wheels<sup>7</sup>, the brass hub shall have a diameter of 4.44 cm [1.75 in.], and the width shall be 1.27 cm [0.50 in.]; weight of the brass hub shall be 145 g [5.11 oz]. Width of the leather covering shall be 1.27 cm [0.50 in.], and the weight of the leather strip shall be 5 g [0.202 oz]. The minimum diameter of the leather covered brass wheel shall be 46 mm [1 13/16 in.].

5.1.3 Vacuum unit<sup>7</sup>, or equivalent, and an optional water trap as shown in Fig. 2. The purpose of the water trap is to protect the vacuum equipment motor, reduce the need to empty the vacuum bag frequently, and minimize readjustment of speed. The inlet pipe to the water trap should be far enough away from the water surface so that undue turbulence is avoided and water does not enter the exhaust line.

5.1.4 Grit Feeding Device<sup>7</sup>, consisting of a storage reservoir for the aluminum oxide grit, grit distribution nozzle, speed control for adjusting grit feed rate, and vacuum pick-up nozzle.

5.2 S-41 Aluminum Oxide Grit<sup>7</sup>, 240 aluminum oxide grit, ANSI B74.12.

5.3 Sieve, No. 80 [180 μm].

between traffic bodies (that is, shoes and a flooring surface). Under continuing exposure to an “abrasive action,” a flooring material may suffer a thickness loss sufficient to reduce its service life.

4.2 Abrasion resistance measurements of resilient floor coverings can be complicated since the resistance to abrasion is affected by many factors. These may include the physical properties of the material in the floor covering surface, particularly its hardness and resilience; type and degree of added substances, such as fillers and pigments; surface characteristics of the specimen, such as type, depth, and amount of embossing. It can also be affected by conditions of the test, including the type and characteristics of the abradant and how it acts on the area of the specimen being abraded; pressure between the specimen and leather clad brass wheels; and vacuum suction.

<sup>7</sup> The sole source of supply of the apparatus known to the committee at this time is Taber Industries, 455 Bryant St., North Tonawanda, NY 14120. If you are aware of alternative suppliers, please provide this information to ASTM Headquarters. Your comments will receive careful consideration at a meeting of the responsible technical committee, which you may attend.

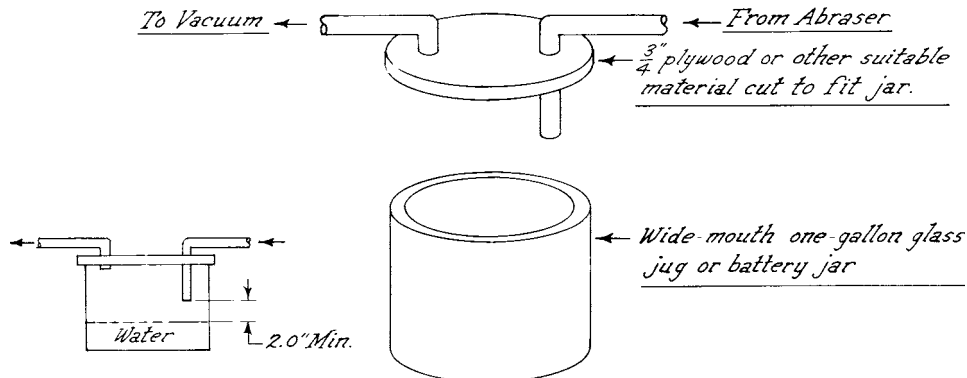

NOTE 1—A vacuum-tight seal between the cover and jar is not required.

FIG. 2 Water Trap

5.4 *Equipment*, for determining specific gravity.

5.5 *Analytical Balance*, for weighing specimens to a precision of 0.001 g.

5.6 *Die or Knife*, for cutting specimens to designated size.

5.7 *Oven*, to dry grit by heating at 82°C [180°F].

5.8 *Static Eliminator Brush*.

## 6. Test Specimens

6.1 *Specimen Thickness*—The standard material thickness that can be evaluated with the Taber abraser is 6.35 mm [0.25 in.] or less. For materials thicker than 6.35 mm [0.25 in.] but less than 12.7 mm [0.50 in.], an extension nut such as type S-21<sup>7</sup> or equivalent may be used.

6.2 *Specimen Size*—The width of the resulting wear path is 12.7 mm [0.50 in.] and is located 31.75 mm [1.25 in.] from the center of the specimen. For most rigid materials, a sample approximately 100 mm [4 in.] square is recommended. If the material is flexible and can be lifted by the vacuum nozzle, a round specimen approximately 100 mm [4 in.] in diameter is suggested to permit the use of the specimen table hold down ring. A 6.5 mm [0.25 in.] diameter hole is drilled through the precise center of the specimen to allow fastening to the specimen holder.

6.3 The required number of specimens for each test shall be indicated in the material specification. If no number is given, four samples shall be taken from the material and one determination made on each. The average of the four or otherwise specified measurements shall be taken as the abrasion loss for the material.

## 7. Calibration and Standardization

7.1 Adjust the abrader with the grit feeder for proper operation using cast acrylic sheet<sup>7</sup> such as S-38 standardization plates as the standard material. The equipment, when running properly, shall produce an average weight loss of  $127.5 \pm 10$  mg for four specimens and  $127.5 \pm 18$  mg for an individual test at 2000 revolutions (Note 2). Operation of the equipment for calibration shall be as described in Section 9, except that specific gravity will not need to be determined.

NOTE 1—Prior to use, the leather clad wheels must be broken in. To do this, subject the wheels to an initial test of 2000 cycles on an S-38 standardization plate with results to be discarded.

NOTE 2—If the desired weight loss is not obtained, check on the following: grit feed rate, path of the grit, removal of the grit, condition of the leather on the wheels, free rotation of wheel bearings, specimen slippage, static charge effects, humidity control, faulty revolution counter, and weighing errors.

## 8. Conditioning

8.1 For those tests where conditioning is required, condition the specimens at  $23 \pm 2^\circ\text{C}$  [ $73.4 \pm 3.6^\circ\text{F}$ ] and  $50 \pm 5\%$  relative humidity for not less than 40 h prior to test in accordance with Practice D1860.

8.2 *Test Conditions*—Conduct tests in the standard laboratory atmosphere of  $23 \pm 2^\circ\text{C}$  [ $73.4 \pm 3.6^\circ\text{F}$ ] and  $50 \pm 5\%$  relative humidity unless otherwise agreed upon by the interested parties.

## 9. Procedure

9.1 Determine the specific gravity of the material to be tested in accordance with standard analytical procedures, such as Method A-1 or A-2 in Test Methods D792. If the specimen as received is not homogeneous but possesses a surface that differs from the body or core, determine the specific gravity of the surface alone. If abrasion is to be carried beyond the surface of the body, also determine the specific gravity of the latter and calculate and report the abrasion resistance of the two components separately.

9.2 Screen the grit through a U.S. Standard Sieve No. 80 [180  $\mu\text{m}$ ] and dry for 1 h at 82°C [180°F]. Allow the grit to cool in a temperature and humidity controlled room prior to use.

9.3 Fill the grit reservoir with grit. Adjust the rate of feed to  $350 \pm 50$  mg per 100 specimen revolutions. The feed rate may be measured by holding a tared petri dish under the nozzle of the grit feeder for 100 specimen revolutions and weighing the amount of grit delivered. The feed rate may be controlled by adjusting the motor speed. The collected grit may be returned to the grit reservoir. It is suggested that the grit feed rate check be made after every third run.

9.4 When the specimens have been prepared and conditioned, brush with the static eliminator and record the initial values for weight to the nearest 0.001 g. Handle samples with care to eliminate contact with moisture from the hands or other environmental contact.

9.5 Place the specimen face up over the rubber mat on the turntable platform. Secure the specimen using the clamp plate and nut. The hold down ring may be used with circular specimens, to keep the specimen from lifting.

9.6 Adjust the feeder nozzle so that it is no higher than 6.5 mm [0.25 in.] above the specimen and so that the stream of grit delivered will evenly cover the wear path generated by the wheels. This should be done prior to the start of the test.

9.7 It is essential that the grit feeding device is positioned correctly such that the abrasive grit falls in the path of the wheels. The correct location of the feeder can be checked by collecting grit for one revolution on a calibration plate containing concentric circles of various radii. The location of the grit pattern can then be compared with the wear path recorded on a poly(methyl methacrylate) (PMMA) or other transparent plate.

9.8 Place the 1000-g weights provided with the apparatus on each of the abraser arms. Fasten the leather-covered wheels to each arm and lower to the specimen surface. The leather rollers should be replaced when one third of the original thickness of the leather clad is reached. This will occur in approximately 45 000 specimen revolutions.

NOTE 3—Accessory weight references are per arm (not combined), and include the mass of the pivoted arm.

9.9 Position the grit removal vacuum nozzle and adjust the settings so that all grit will be removed after passing under the wheels.

9.10 Adjust the counter to zero and start the machine.