INTERNATIONAL STANDARD



3365 / 1

INTERNATIONAL ORGANIZATION FOR STANDARDIZATION • МЕЖДУНАРОДНАЯ ОРГАНИЗАЦИЯ ПО СТАНДАРТИЗАЦИИ • ORGANISATION INTERNATIONALE DE NORMALISATION

**Indexable (throwaway) carbide inserts for milling cutters —
Dimensions —
Part I : Square inserts**

Plaquettes amovibles en carbures métalliques pour fraises — Dimensions — Partie I : Plaquettes carrées

iTeh STANDARD PREVIEW

First edition — 1977-07-01

(standards.iteh.ai)

[ISO 3365-1:1977](https://standards.iteh.ai/catalog/standards/sist/28540f6c-49c0-4f2d-85a1-75ad8a512557/iso-3365-1-1977)

<https://standards.iteh.ai/catalog/standards/sist/28540f6c-49c0-4f2d-85a1-75ad8a512557/iso-3365-1-1977>

UDC 621.914.025.7

Ref. No. ISO 3365/I-1977 (E)

Descriptors : tools, cutting tools, milling cutters, carbide tools, inserts, designation, marking, symbols, dimensions, dimensional tolerances.

Price based on 5 pages

Indexable (throwaway) carbide inserts for milling cutters — Dimensions — Part I : Square inserts

1 SCOPE AND FIELD OF APPLICATION

This International Standard specifies the dimensions of square indexable (throwaway) carbide inserts intended to be mounted mechanically, and not by brazing, on face milling cutters.

Triangular inserts are dealt with in ISO 3365/II.

2 REFERENCES

ISO 513, *Application of carbides for machining by chip removal — Designation of the main groups of chip removal and groups of application.*

ISO 1832, *Indexable (throwaway) inserts for cutting tools — Designation — Code of symbolization.*

ISO 3365/II, *Indexable (throwaway) carbide inserts for milling cutters — Dimensions — Part II : Triangular inserts.*¹⁾

3 INTERCHANGEABILITY

Dimension *m* specified in the tables refers to a theoretically perfect insert. In practice, as the points on which the inserts are located in both manufacture and measuring may be different, the nominal value of dimension *m* may vary from one manufacturer to another within a range of $\pm 0,05$ mm. Nevertheless, for inserts of the same manufacturer, dimension *m* shall comply with the tolerances according to ISO 1832 (see the annex).

4 TYPES OF INSERTS

The types of square indexable carbide inserts for milling cutters are the following :

- SN EN : Square inserts with chamfered corners, 75° cutting edge angle and 0° normal clearance.

- SP ED : Square inserts with chamfered corners, 75° cutting edge angle, 11° normal clearance and 15° wiper edge normal clearance.
- SP EP : Square inserts with chamfered corners, 75° cutting edge angle, 11° normal clearance and 11° wiper edge normal clearance.
- SN AN : Square inserts with 45° cutting edge angle and 0° normal clearance.

5 TOLERANCES

Indexable (throwaway) carbide inserts to this International Standard are provided in tolerance classes A, C or K, according to ISO 1832. The values of these tolerances are given in the annex.

6 DESIGNATION AND MARKING

6.1 Designation

The designation of the indexable (throwaway) carbide inserts for milling cutters complying with this International Standard shall conform to ISO 1832.

In addition to this designation, one or both of the following may be indicated :

- the symbol of the group of application, according to ISO 513;
- the commercial designation of the carbide grade.

6.2 Marking

The following symbol, at least, shall be marked on the insert itself :

- symbol of the group of application, or commercial designation of the carbide grade (or both, if possible, on large inserts).

1) At present at the stage of draft.

7.2 Square inserts with chamfered corners, 75° cutting edge angle, 11° normal clearance and 11° or 15° wiper edge normal clearance

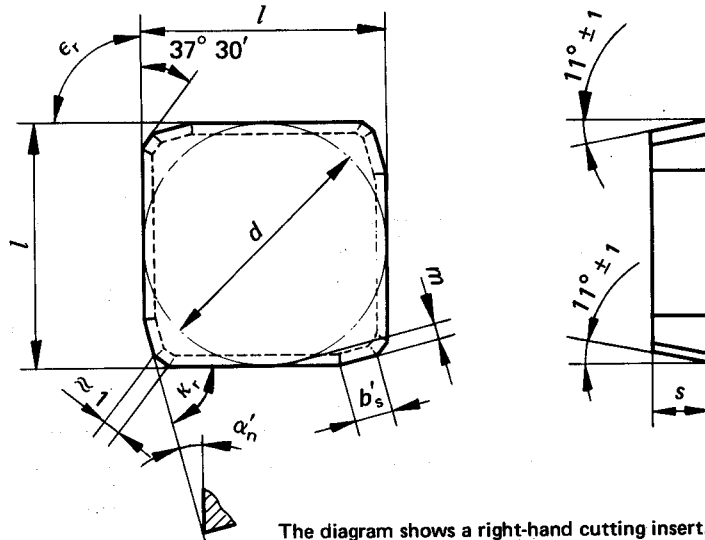

The diagram shows a right-hand cutting insert.

Designation		$l = d$	s	b'_s	m	ϵ_r	κ_r	α'_n		
metric	inch	1)	1)	≈	1)	tol.	tol.	± 1°		
SPAN1203EDR SPAN1203EDL	SPAN42EDR SPAN42EDL	12,700	3,175	1,4	0,90	90°	75°	15°		
SPCN1203EDR SPCN1203EDL	SPCN42EDR SPCN42EDL								± 8'	+ 15' 0
SPKN1203EDR SPKN1203EDL	SPKN42EDR SPKN42EDL								± 15'	+ 30' 0
SPAN1203EPR SPAN1203EPL	SPAN42EPR SPAN42EPL	12,700	3,175	1,4	0,90	90°	75°	11°		
SPCN1203EPR SPCN1203EPL	SPCN42EPR SPCN42EPL								± 8'	+ 15' 0
SPKN1203EPR SPKN1203EPL	SPKN42EPR SPKN42EPL								± 15'	+ 30' 0
SPAN1504EDR SPAN1504EDL	SPAN53EDR SPAN53EDL	15,875	4,76	1,4	1,25	90°	75°	15°		
SPCN1504EDR SPCN1504EDL	SPCN53EDR SPCN53EDL								± 8'	+ 15' 0
SPKN1504EDR SPKN1504EDL	SPKN53EDR SPKN53EDL								± 15'	+ 30' 0
SPAN1504EPR SPAN1504EPL	SPAN53EPR SPAN53EPL	15,875	4,76	1,4	1,25	90°	75°	11°		
SPCN1504EPR SPCN1504EPL	SPCN53EPR SPCN53EPL								± 8'	+ 15' 0
SPKN1504EPR SPKN1504EPL	SPKN53EPR SPKN53EPL								± 15'	+ 30' 0

1) Tolerances on d , m and s according to ISO 1832. See the annex.

ANNEX

EXTRACT FROM ISO 1832
Tolerances on d , m and s – Tolerance classes A, C and K.

d	Tolerance on d		Tolerance on m		Tolerance on s
	Tolerance classes		Tolerance classes		Tolerance classes
	A and C	K	A	C and K	A, C and K
12,700	± 0,025	± 0,08	± 0,005	± 0,013	± 0,025
15,875		± 0,10			
19,050					

iTeh STANDARD PREVIEW
(standards.iteh.ai)

ISO 3365-1-1977

<https://standards.iteh.ai/catalog/standards/sist/28540f6c-49c0-4f2d-85a1-75ad8a512557/iso-3365-1-1977>