



# Standard Test Methods for Nonrigid Vinyl Chloride Polymer Tubing Used for Electrical Insulation<sup>1</sup>

This standard is issued under the fixed designation D876; the number immediately following the designation indicates the year of original adoption or, in the case of revision, the year of last revision. A number in parentheses indicates the year of last reapproval. A superscript epsilon ( $\epsilon$ ) indicates an editorial change since the last revision or reapproval.

*This standard has been approved for use by agencies of the U.S. Department of Defense.*

## 1. Scope\*

1.1 These test methods cover the testing of general-purpose (Grade A), low-temperature (Grade B), and high-temperature (Grade C)<sup>2</sup> nonrigid vinyl chloride polymer tubing, or its copolymers with other materials, for use as electrical insulation. For the purpose of these test methods nonrigid tubing shall be tubing having an initial elongation in excess of 100 % at break.

NOTE 1—These test methods are similar but not identical to those in IEC 60684–2.

1.2 The values stated in inch-pound units are to be regarded as standard, except for temperature, which shall be expressed in degrees Celsius. The values given in parentheses are mathematical conversions to SI units that are provided for information only and are not considered standard.

1.3 The procedures appear in the following sections:

Procedure	Section	ASTM Reference Standard
Brittleness Temperature	43 – 45	D746
Corrosion Tests	74 – 85	D1000
Dielectric Breakdown Voltage at High Humidity	65 – 73	E104
Dielectric Breakdown Voltage	58 – 64	D149
Dimensional Tests	8 – 14	D374
Effect of Elevated Temperatures	25 – 36	D412
Flammability Test	15 – 21	
Oil Resistance Test	35 – 42	D471
Penetration Test	46 – 51	
Sampling	6	
Strain Relief Test	68 – 73	
Tension Test	22 – 24	D412
Test Conditions	73 – 80	
Volume Resistivity	52 – 57	D257

1.4 *This standard does not purport to address all of the safety concerns, if any, associated with its use. It is the responsibility of the user of this standard to establish appropriate safety and health practices and determine the applicability of regulatory limitations prior to use.* For specific hazard statements, see Section 5.

1.5 *For fire test caveats, see Section 15.*

## 2. Referenced Documents

2.1 *ASTM Standards:*<sup>3</sup>

[D149 Test Method for Dielectric Breakdown Voltage and Dielectric Strength of Solid Electrical Insulating Materials at Commercial Power Frequencies](#)

[D257 Test Methods for DC Resistance or Conductance of Insulating Materials](#)

[D374 Test Methods for Thickness of Solid Electrical Insulation \(Withdrawn 2013\)](#)<sup>4</sup>

[D412 Test Methods for Vulcanized Rubber and Thermoplastic Elastomers—Tension](#)

<sup>1</sup> These test methods are under the jurisdiction of ASTM Committee D09 on Electrical and Electronic Insulating Materials and are the direct responsibility of Subcommittee D09.07 on Flexible and Rigid Insulating Materials.

Current edition approved Oct. 1, 2009; Nov. 1, 2013. Published November 2009; December 2013. Originally approved in 1946. Last previous edition approved in 2007 as ~~D876—00~~D876—09 (2007).<sup>1</sup> DOI: ~~10.1520/D0876-09~~10.1520/D0876-13.

<sup>2</sup> Test methods applicable to Grade B will be specified at a later date.

<sup>3</sup> For referenced ASTM standards, visit the ASTM website, [www.astm.org](http://www.astm.org), or contact ASTM Customer Service at [service@astm.org](mailto:service@astm.org). For *Annual Book of ASTM Standards* volume information, refer to the standard's Document Summary page on the ASTM website.

<sup>4</sup> The last approved version of this historical standard is referenced on [www.astm.org](http://www.astm.org).

\*A Summary of Changes section appears at the end of this standard

[D471 Test Method for Rubber Property—Effect of Liquids](#)  
[D746 Test Method for Brittleness Temperature of Plastics and Elastomers by Impact](#)  
[D1000 Test Methods for Pressure-Sensitive Adhesive-Coated Tapes Used for Electrical and Electronic Applications](#)  
[D1711 Terminology Relating to Electrical Insulation](#)  
[D5032 Practice for Maintaining Constant Relative Humidity by Means of Aqueous Glycerin Solutions](#)  
[E104 Practice for Maintaining Constant Relative Humidity by Means of Aqueous Solutions](#)  
[E176 Terminology of Fire Standards](#)

2.2 *IEC Standards:*

[60684–2 Flexible insulating sleeving, Part 2, Methods of test](#)<sup>5</sup>

### 3. Terminology

3.1 *Definitions:*

3.1.1 For definitions pertaining to electrical insulation, refer to Terminology [D1711](#).

3.1.2 For definitions pertaining to fire standards, refer to Terminology [E176](#).

3.2 *Definitions of Terms Specific to This Standard:*

3.2.1 *brittleness temperature, n*—that temperature at which 50 % of the specimens fail when the specified number are tested, using the apparatus and conditions specified.

3.2.2 *corrosive effect, n*—under the prescribed conditions, the percentage change in electrical resistance of a fine copper wire in contact with the tubing.

3.2.3 *resistance to penetration, n*—that property of tubing indicated by its resistance to high local pressures, as determined by the temperature at which a steel ball punctures the tubing under the conditions of loading and temperature rise specified in these test methods.

3.2.4 *wall thickness, n*—an average value determined as one half of the difference between the inside and outside diameters of the tubing measured by the test method prescribed herein.

### 4. Significance and Use

4.1 These test methods include most of the test methods that are considered important to characterize nonrigid vinyl chloride polymer tubing. While they were developed initially for this type of extruded tubing, their use is not limited to this type of tubing.

4.2 Variations in these test methods or alternate contemporary methods ~~may be used to~~ are acceptable for use determine the values for the properties in this standard provided such methods ensure quality levels and measurement accuracy equal to or better than those prescribed herein. It is the responsibility of the organizations using alternate test methods to be able to demonstrate this condition. In cases of dispute, the test methods specified herein shall be used.

NOTE 2—Provision for alternate methods is necessary because of (1) the desire to simplify procedures for specific applications without altering the result, and (2) the desire to eliminate redundant testing and use data generated during manufacturing process control, including that generated under Statistical Process Control (SPC) conditions, using equipment and methods other than those specified herein. An example would be the use of laser micrometers or optical comparators to measure dimensions.

### 5. Hazards

5.1 *Lethal voltages are a potential hazard during the performance of this test. It is essential that the test apparatus, and all associated equipment electrically connected to it, be properly designed and installed for safe operation. Solidly ground all electrically conductive parts which it is possible for a person to contact during the test. Provide means for use at the completion of any test to ground any parts which were at high voltage during the test or have the potential for acquiring an induced charge during the test or retaining a charge even after disconnection of the voltage source. Thoroughly instruct all operators as to the correct procedures for performing tests safely. When making high voltage tests, particularly in compressed gas or in oil, it is possible for the energy released at breakdown to be sufficient to result in fire, explosion, or rupture of the test chamber. Design test equipment, test chambers, and test specimens so as to minimize the possibility of such occurrences, and to eliminate the possibility of personal injury. If the potential for fire exists, have fire suppression equipment available.*

### 6. Sampling

6.1 Select a sufficient number of pieces of tubing in such a manner as to be representative of the shipment.

6.2 Cut the number of specimens required for the purpose of tests from the pieces selected in accordance with [6.1](#), taking care to select material that is free from obvious defects.

### 7. Test Conditions

7.1 Unless otherwise specified in these test methods, conduct tests at atmospheric pressure and at a temperature of  $23 \pm 2$  °C ( $73 \pm 4$  °F). Room temperature, as stated in these test methods, shall be within this temperature range.

<sup>5</sup> Available from American National Standards Institute (ANSI), 25 W. 43rd St., 4th Floor, New York, NY 10036, <http://www.ansi.org>.

**DIMENSIONAL TESTS**
**8. Significance and Use**

8.1 The inside diameter and wall thickness are of importance as a measure of dimensional uniformity. They also provide important data for design purposes, and are used in the calculation of certain physical and electrical properties of the tubing.

**9. Apparatus**

9.1 *Tapered-Steel Gages*—Use chromium-plated gages suitable for covering the range of tubing sizes shown in **Table 1**. The gages shall have a uniform taper of 0.010 in./1 in. (0.010 mm/mm) of length, and shall be graduated with circular lathe-cut rings every 0.5 in. (13 mm) of length. The graduations shall then represent a uniform increase in diameter of 0.005 in./0.5 in. (0.010 mm/mm) of length.

9.2 *Micrometers*—Use machinist’s type micrometers suitable for covering the range of tubing sizes shown in **Table 1**.

9.3 *Steel Scale*—A steel scale graduated in 0.01 in. (0.25 mm).

**10. Test Specimens**

10.1 Cut a 1-in. (25-mm) specimen free of kinks from the sample. Perform this operation perpendicular to the longitudinal axis of the tubing specimen, giving a specimen 1 in. in length having cleanly cut square ends.

**11. Procedure for Measuring Inside Diameter**

11.1 Select a gage that will fit part way into the tubular specimen. Slip the specimen, without forcing (**Note 3**), over the gage until there is no visible air space between the end of the specimen and the gage anywhere on the circumference. Consider this point on the gage the inside diameter of the specimen.

**NOTE 3**—When the tubing specimen tends to stick, ~~the gage may be dipped~~ it is acceptable to dip the gage in water to facilitate slipping the specimen over the gage. However, when water is used as a lubricant on the gage, ~~great caution should be exercised to make certain~~ exercise sufficient caution to ensure that the specimen is not forced on the gage, thereby stretching the specimen.

**TABLE 1 Tubing Sizes**

Size	Inside Diameter, in. <sup>A</sup>		
	Max	Min	Nominal
2 in.	2.070	2.000	....
1¾ in.	1.812	1.750	....
1½ in.	1.550	1.500	....
1¼ in.	1.290	1.250	....
1 in.	1.036	1.000	....
¾ in.	0.911	0.875	....
½ in.	0.786	0.750	....
⅜ in.	0.655	0.625	....
¼ in.	0.524	0.500	....
⅓ in.	0.462	0.438	....
⅔ in.	0.399	0.375	....
⅞ in.	0.334	0.3125	....
No. 0	0.347	0.325	0.330
No. 1	0.311	0.289	0.294
No. 2	0.278	0.258	0.263
No. 3	0.249	0.229	0.234
No. 4	0.224	0.204	0.208
No. 5	0.198	0.182	0.186
No. 6	0.178	0.162	0.166
No. 7	0.158	0.144	0.148
No. 8	0.141	0.129	0.133
No. 9	0.124	0.114	0.118
No. 10	0.112	0.102	0.106
No. 11	0.101	0.091	0.095
No. 12	0.089	0.081	0.085
No. 14	0.072	0.064	0.066
No. 16	0.061	0.051	0.053
No. 18	0.049	0.040	0.042
No. 20	0.039	0.032	0.034

<sup>A</sup> NOTE—One inch equals 25.4 mm.

11.2 Determine the diameter at the point of contact between the specimen and gage by referring to the nearest visible graduation. With the steel scale, measure any distance between the edge of the specimen and the nearest graduation. Each 0.1 in. (2.5 mm) on the length of the gage represents an increase of 0.001 in. (0.025 mm) in diameter. Since the diameter at the nearest graduation is known, obtain the inside diameter of the specimen by interpolation and report to the nearest 0.001 in.

## 12. Procedure for Measuring Outside Diameter

12.1 With the specimen located on the tapered gage as described in 11.1, make three outside diameter measurements approximately 120° apart and adjacent to the edge of each specimen. Make the measurements in accordance with Test Methods D374 using Apparatus B, and observing the following additional details:

- 12.1.1 Support the micrometer to allow both hands to be free for manipulation.
- 12.1.2 Measure the outside diameter adjacent to, but not on or over the cut edge, and
- 12.1.3 Rotate the tubular specimen, which is on the tapered mandrel, so that the rotation is an oscillating motion with the outside surface of the tube just touching the fixed anvil of the micrometer. Slowly move the micrometer spindle onto the surface of the tube until the first definite increase in the resistance to rotation of the specimen is encountered. The micrometer reading at this time is the outside diameter of the specimen.

## 13. Report

13.1 Report the following information:

- 13.1.1 Inside diameter of the specimen to the nearest 0.001 in. (0.025 mm),
- 13.1.2 All readings on outside diameter of the specimen to the nearest 0.001 in.,
- 13.1.3 Average outside diameter, and
- 13.1.4 Average wall thickness.

## 14. Precision and Bias

14.1 The precision of this test method has not been determined due to inadequate voluntary participation and funding needed to conduct the round-robin testing. A statement of bias is unavailable in view of the lack of a standard reference material for this property.

(https://standards.iteh.ai)  
**FLAMMABILITY TEST**  
 Document Preview

## 15. Scope

15.1 This is a fire-test-response standard. The test procedure described measures the resistance of the tubing to ignition or the spread of flame after ignition when tested under the specified conditions.

15.2 *This standard is used to measure and describe the response of materials, products, or assemblies to heat and flame under controlled conditions, but does not by itself incorporate all factors required for fire hazard or fire risk assessment of the materials, products, or assemblies under actual fire conditions.*

15.3 *Fire testing is inherently hazardous. Adequate safeguards for personnel and property shall be employed in conducting these tests.*

## 16. Significance and Use

16.1 This test may be employed as an acceptable test for use to compare tubing made from different compounds provided that specimens with the same dimensions are used, but it is not necessarily a measure of the flammability of the compound.

## 17. Apparatus

17.1 *Sheet Metal Enclosure*—A three-walled sheet metal enclosure 12 in. (300 mm) wide by 14 in. (360 mm) deep by 29 in. (740 mm) high, open at the top. It shall be equipped with two parallel horizontal metal rods 16 in. (410 mm) apart, so situated that a wire stretched perpendicularly across each rod shall be at a 70° angle with the horizontal. The lower rod shall be approximately 2 in. (50 mm) from the rear wall.

17.2 *Bare Steel Wire*—A length of bare steel wire, approximately 0.029 in. (0.74 mm) in diameter, shall be used for supporting the specimens during the test.

17.3 *Burner*—A burner with a 3/8-in. (9.5-mm) nominal bore and suitable for the gas supplied. The tube of the burner shall be approximately 3 1/2 in. (90 mm) long above the primary inlet. It shall be mounted upon a positioning mechanism similar to that shown in Fig. 1. As shown in the figure, a pivoted positioner which forms an extension of the center line of the burner barrel is attached to the barrel of the burner so as to locate the exact point of impingement of the inner cone on the test specimen. The base of the burner shall be tilted 25° from the horizontal during the period that the flame is applied to the specimen, and the flame shall impinge upon the specimen at an angle of 45°. The system shall contain a gas regulating valve as well as a shutoff valve.

Note: Pivoted indicator to be turned down prior to ignition.

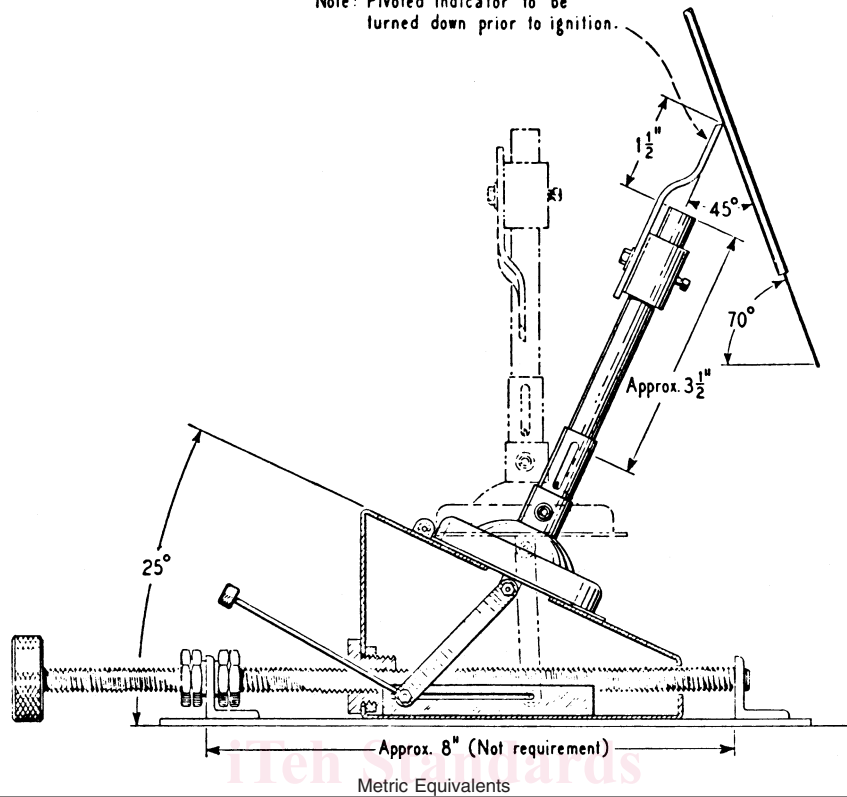

	1 1/2	3 1/2	8
in.	38.1	88.9	203.2
mm			

FIG. 1 Positioning Mechanism for Burner

17.4 *Gas Supply*—Public utility or propane gas may be used. are acceptable for use. For referee purposes, commercial grade propane gas having a nominal heating value of 2521 Btu/ft<sup>3</sup> and a specific gravity of 0.508 at 60 °F shall be used at a line pressure of 11 in. (279 mm) water column.

NOTE 4—Small tanks of this gas may be obtained where regular delivery lines are nonexistent. If no regular delivery lines are available for propane gas, the use of small tanks is an acceptable alternate.

17.5 *Timepiece*—A timepiece measuring seconds shall be provided to measure the duration of flame application and specimen burning time.

17.6 *Flame Indicators*—Strips of gummed paper shall be provided to be used in determining the length of specimen burned.

## 18. Test Specimens

18.1 Cut five test specimens approximately 22 in. (560 mm) in length from the sample.

## 19. Procedure

19.1 Conduct the test with the enclosure situated in a hood or cabinet free from drafts. Draw the specimen onto the wire. Attach the specimen and the wire at one end to the middle of the upper horizontal bar by kinking the tubing and clamping so as to provide a closed end to the specimen, thus preventing any chimney effects during the test. Pass the lower end of the wire protruding from the open end of the tubing over the middle of the lower horizontal bar, and hold it taut against the bar by a weight of at least 1 lb (500 g), attached to the free end of the wire. In the case of tubing having a cross section deviating from circular, position the edge having the smallest radius of curvature nearest the flame. Attach the paper indicator to the specimen so that the lower edge is 10 in. (250 mm) above the point of flame application.

19.2 With the burner in a vertical position adjust the height of the flame to 5 in. (130 mm) with the inner cone at 1 1/2 in. (40 mm). The distance between the end of the burner and the edge of the test specimen shall be 1 1/2 in. measured along the axis of the burner. After preliminary positioning of the burner and before lighting the burner preparatory to application of the flame to the tubing, pivot the positioner away from the flame area. The burner shall be in an upright position when ignited and shall be dropped into testing position at the instant that the timer is started. Apply the flame to the specimen for 15 s and then extinguish it by turning off the gas supply from outside the test cabinet.

19.3 Determine the duration of burning of the specimen from the time of extinction of the gas flame. Determine the length of specimen burned either by direct measurement or by subtracting the length of the unburned portion from 10 in. (25.4 cm).

## 20. Report

20.1 Report the following information:

20.1.1 Inside diameter and average wall thickness of the sample, in inches, from which the specimens were taken (Sections 11 and 12),

20.1.2 Maximum and minimum durations of burning, in seconds, for the five specimens; and the average duration of burning based on the remaining three tests, after the exclusion of one maximum and one minimum value, and

20.1.3 Maximum and minimum burned lengths, in inches, for the five specimens, and the average burned length based on the remaining three tests, after the exclusion of one maximum and one minimum value.

20.2 The results are the average duration of burning and the average burned length based on the remaining three tests after exclusion of one maximum and one minimum value.

## 21. Precision and Bias

21.1 The precision of this test method has not been determined due to inadequate voluntary participation and funding needed to conduct the round-robin testing. This test method has no bias because the results are expressed purely in terms of this test method.

## TENSION TEST

## 22. Procedure

22.1 Determine the tensile strength and ultimate elongation in accordance with Test Methods D412, with the following exceptions:

22.1.1 For sizes No. 20 to 0, inclusive, prepare six test specimens by cutting lengths from the sample and subjecting them to the tension test in tubing form.

22.1.2 For sizes  $\frac{5}{16}$  in. to 2 in. (7.9 to 50 mm), inclusive, in inside diameter prepare six test specimens taken from the sample in the form as represented by Die B of Test Methods D412. Do this by cutting one wall along a longitudinal axis, flattening the piece, and applying Die B parallel to this axis.

22.1.3 Measure the inside and outside diameters in accordance with Sections 9 – 13.

22.1.4 In determining the tensile strength use the average area of the specimens selected.

22.1.5 Mark two parallel gage lines for use in determining elongation on the tubing, perpendicular to the longitudinal axis, one on each side of the center and 1 in. (25 mm) therefrom.

22.1.6 Make the distance between grips of the testing machine 4 in. (100 mm).

22.1.7 Use a uniform rate of travel of the power actuated grip of 12 in. (305 mm)/min.

22.1.8 Discard results on specimens that break outside of the gage marks and retest.

## 23. Report

23.1 Report the following information:

23.1.1 Size of tubing from which the specimens were taken,

23.1.2 All observed and recorded data on which the calculations are based,

23.1.3 Average tensile strength determined on the best five out of six specimens, and

23.1.4 Average ultimate elongation determined on the best five out of six specimens.

## 24. Precision and Bias

24.1 The precision of this test method has not been determined due to inadequate voluntary participation and funding needed to conduct the round-robin testing. A statement of bias is unavailable in view of the lack of a standard reference material for this property.

## EFFECT OF ELEVATED TEMPERATURES

## 25. Scope

25.1 The effect of elevated temperature is indicated by the changes in ultimate elongation and weight caused by exposure of the tubing to elevated temperatures for a specified time under controlled conditions of air circulation.

## 26. Significance and Use

26.1 Loss of elongation or weight as caused by exposure of the tubing to elevated temperatures is indicative of factors such as volatile constituents or chemical changes in the tubing. The temperature used is higher than that recommended for continuous