



Designation: **D4180 – 03 (Reapproved 2008) D4180 – 13**

Standard Test Method for Vibratory Packing Density of Formed Catalyst Particles and Catalyst Carriers¹

This standard is issued under the fixed designation D4180; the number immediately following the designation indicates the year of original adoption or, in the case of revision, the year of last revision. A number in parentheses indicates the year of last reapproval. A superscript epsilon (ϵ) indicates an editorial change since the last revision or reapproval.

1. Scope

1.1 This test method covers the determination of the vibratory packing density of formed catalyst and catalyst carriers. For the purpose of this test, catalyst particles are defined as extrudates, spheres, or formed pellets of 0.8 to 4.8-mm ($1/32$ to $3/16$ -in.) nominal diameter.

1.2 The values stated in SI units are to be regarded as the standard. The values given in parentheses are for information only.

1.3 *This standard does not purport to address all of the safety concerns, if any, associated with its use. It is the responsibility of the user of this standard to establish appropriate safety and health practices and determine the applicability of regulatory limitations prior to use.*

2. Referenced Documents

2.1 *ASTM Standards:*²

[D3766 Terminology Relating to Catalysts and Catalysis](#)

[E177 Practice for Use of the Terms Precision and Bias in ASTM Test Methods](#)

[E456 Terminology Relating to Quality and Statistics](#)

[E691 Practice for Conducting an Interlaboratory Study to Determine the Precision of a Test Method](#)

[E1272 Specification for Laboratory Glass Graduated Cylinders](#)

3. Terminology

3.1 *Definitions*—See Terminology [D3766](#).

4. Summary of Test Method

4.1 A preconditioned sample of formed catalyst or catalyst carrier is vibrated in a cylinder. The vibratory packing density is determined from a known mass and vibrated volume.

5. Significance and Use

5.1 This test method is to be used for measuring the vibratory packing density of formed particles that will not break up during sampling, filling, or vibrating of the measuring cylinder under test conditions.

6. Apparatus

6.1 *Glass Cylinders*, capacity 250 mL, feed and measuring-measuring, conforming to Specification [E1272](#), Class A.

6.2 *Vibrator*,³ conventional handheld, with hard rubber or metal impactor.

6.3 *Feed Funnel*, plastic, glass, or metal as shown in [Fig. 1](#).

6.4 *Ring Stand, Vibrator Holder and Clamps* as shown in [Figs. 2 and 3](#).

¹ This test method is under the jurisdiction of ASTM Committee [D32](#) on Catalysts and is the direct responsibility of Subcommittee [D32.02](#) on Physical-Mechanical Properties.

Current edition approved April 1, 2008; Dec. 1, 2013. Published April 2008/December 2013. Originally approved in 1988. Last previous edition approved in 2003/2008 as [D4180-03 \(2008\)-03](#); DOI: [10.1520/D4180-03R08-10.1520/D4180-13](#).

² For referenced ASTM standards, visit the ASTM website, [www.astm.org](#), or contact ASTM Customer Service at [service@astm.org](#). For *Annual Book of ASTM Standards* volume information, refer to the standard's Document Summary page on the ASTM website.

³ The sole source of supply of the ~~Wahl Vibrator, Model 4180, 4 in 1, 120 V 60 Hz 11-W vibrator~~ known to the committee at this time is Wahl Clipper Corp., Sterling, IL. ~~Model 4120 used at low speed is recommended to replace Model 4180, which is discontinued.~~ If you are aware of alternative suppliers, please provide this information to ASTM International Headquarters. Your comments will receive careful consideration at a meeting of the responsible technical committee,¹ which you may attend.

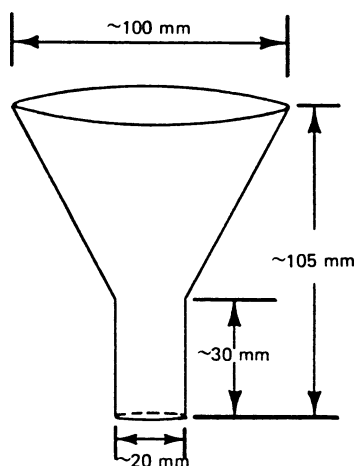

FIG. 1 Feed Funnel

6.5 *Desiccator*, with a desiccant grade molecular sieve such as a No. 4A.

6.6 *Balance* having sensitivity of 0.1 g.

6.7 *Drying Oven*.

7. Procedure

7.1 Heat an adequate sample(s) at $400 \pm 15^\circ\text{C}$ for not less than 3 h. Normally, this treatment can take place in air. However, in the case of materials that might react with air at elevated temperatures (such as prereduced catalysts) the heat treatment should take place in an inert atmosphere. Cool after heating the test sample(s) in a desiccator or other suitable container to eliminate the possibility of moisture adsorption prior to testing.

NOTE 1—These conditions may not be appropriate for all materials.

NOTE 2—Since many catalyst formulations are strong adsorbents, the use of a No. 4A indicating (cobalt-treated) molecular sieve as a desiccating medium is suggested. The desiccant should be regenerated at 220 to 260°C as required.

7.2 Fill a tared feed-glass cylinder with 250 mL of loosely packed, dried catalyst and weigh immediately to the nearest 0.1 g.

7.3 Turn on the vibrator and carefully add the sample(s) to the measuring cylinder through the feed funnel.

7.4 Transfer all the catalyst to the measuring cylinder at a uniform rate not less than 2 mL/s or exceeding 3 mL/s. The entire transfer time should be between 83 and 125 s.

7.5 After an additional 60 s turn off vibrator. Read the vibrated volume, V , to the nearest 1 mL by estimating the average level of the catalyst surface in the cylinder.

8. Calculation

8.1 Calculate the vibratory packing density VPD as follows:

$$VPD = W/V$$

where:

W = mass of catalyst particles, g, and

V = volume occupied by catalyst particles in measuring cylinder, mL.

8.2 Vibratory packing densities are typically reported to three significant figures.

9. Precision and Bias⁴

9.1 *Test Program*—An interlaboratory study was conducted in which the named property was measured in two separate test materials in five separate laboratories. Practice E691, modified for nonuniform data sets, was followed for the data reduction.

9.2 *Precision*—Pairs of test results obtained by a procedure similar to that described in the study are expected to differ in absolute value by less than 2.772 S, where 2.772 S is the 95 % probability interval limit on the difference between two test results, and S is the appropriate estimate of standard deviation. Definitions and usage are given in Terminology E456 and Practice E177, respectively.

⁴ Supporting data have been filed at ASTM International Headquarters and may be obtained by requesting Research Report RR:D32-1018.