



Designation: **C882/C882M—13** C882/C882M – 13a

# Standard Test Method for Bond Strength of Epoxy-Resin Systems Used With Concrete By Slant Shear<sup>1</sup>

This standard is issued under the fixed designation C882/C882M; the number immediately following the designation indicates the year of original adoption or, in the case of revision, the year of last revision. A number in parentheses indicates the year of last reapproval. A superscript epsilon ( $\epsilon$ ) indicates an editorial change since the last revision or reapproval.

## 1. Scope\*

1.1 This test method covers the determination of the bond strength of epoxy-resin-base bonding systems for use with portland-cement concrete. This test method covers bonding hardened concrete to hardened or freshly-mixed concrete.

1.2 The values stated in either SI units or inch-pound units are to be regarded separately as standard. The values stated in each system may not be exact equivalents; therefore, each system shall be used independently of the other. Combining values from the two systems may result in non-conformance with the standard.

1.3 *This standard does not purport to address all of the safety concerns, if any, associated with its use. It is the responsibility of the user of this standard to establish appropriate safety and health practices and determine the applicability of regulatory limitations prior to use.* A specific hazard statement is given in Section 8. (**Warning**—Fresh hydraulic cementitious mixtures are caustic and may cause chemical burns to exposed skin and tissue upon prolonged exposure.<sup>2</sup>)

## 2. Referenced Documents

### 2.1 ASTM Standards:<sup>3</sup>

[C39/C39M Test Method for Compressive Strength of Cylindrical Concrete Specimens](#)

[C109/C109M Test Method for Compressive Strength of Hydraulic Cement Mortars \(Using 2-in. or \[50-mm\] Cube Specimens\)](#)

[C125 Terminology Relating to Concrete and Concrete Aggregates](#)

[C150 Specification for Portland Cement](#)

[C192/C192M Practice for Making and Curing Concrete Test Specimens in the Laboratory](#)

[C470/C470M Specification for Molds for Forming Concrete Test Cylinders Vertically](#)

[C511 Specification for Mixing Rooms, Moist Cabinets, Moist Rooms, and Water Storage Tanks Used in the Testing of Hydraulic Cements and Concretes](#)

[C617 Practice for Capping Cylindrical Concrete Specimens](#)

[C881/C881M Specification for Epoxy-Resin-Base Bonding Systems for Concrete](#)

## 3. Terminology

### 3.1 Definitions:

3.1.1 For definitions of terms used in this specification, refer to Terminology [C125](#).

### 3.2 Definitions of Terms Specific to This Standard:

3.2.1 *bonding system, n*—the product resulting from the combination of all the components supplied for use as a bonding material.

3.2.2 *component, n*—a constituent that is intended to be combined with one or more other constituents to form a bonding system.

3.2.3 *contact strength, n*—bond strength measured by slant shear after a specified contact and cure time.

3.2.4 *contact time, n*—specified time between when the bonding system is applied and when the two segments are bonded together and still achieve a specified bond strength after a specified curing time and temperature.

<sup>1</sup> This test method is under the jurisdiction of ASTM Committee [C09](#) on Concrete and Concrete Aggregates and is the direct responsibility of Subcommittee [C09.25](#) on Organic Materials for Bonding.

Current edition approved June 15, 2013. Published August 2013. Originally approved in 1978. Last previous edition approved in 2012 as C882/C882M-12-13. DOI: 10.1520/C0882-C0882M-13-10.1520/C0882\_C0882M-13a.

<sup>2</sup> See Section on Safety Precautions, Manual of Aggregate and Concrete Testing, *Annual Book of ASTM Standards*, Vol. 04.02.

<sup>3</sup> For referenced ASTM standards, visit the ASTM website, [www.astm.org](http://www.astm.org), or contact ASTM Customer Service at [service@astm.org](mailto:service@astm.org). For *Annual Book of ASTM Standards* volume information, refer to the standard's Document Summary page on the ASTM website.

\*A Summary of Changes section appears at the end of this standard

3.2.5 *formulator, n*—the agency responsible for preparing the separate components and for recommending the proportions to be used in preparing the final bonding system.

#### 4. Summary of Test Method

4.1 The bond strength is determined by using the epoxy system to bond together two equal sections of a 75 by 150-mm [3 by 6-in.] portland-cement mortar cylinder, each section of which has a diagonally cast bonding area at a 30° angle from vertical. After suitable curing of the bonding agent, the test is performed by determining the compressive strength of the composite cylinder.

#### 5. Significance and Use

5.1 The strength developed by a bonding system that joins two regions of concrete is its most important property.

#### 6. Apparatus

6.1 *Apparatus to Mix Portland-Cement Mortar*—This apparatus shall be as described in Test Method C109/C109M, except for the sections on specimen molds, tamper, and testing machine.

6.2 *Specimen Molds*—The molds shall meet the requirements of Specification C470/C470M and be 75 ± 2 mm [3 ± 1/16 in.] in inside diameter and 150 ± 2 mm [6 ± 1/16 in.] in height.

6.3 *Dummy Section*—A dummy section (Fig. 1) shall be machined of a hard material that is not attacked by portland-cement mortar. It shall fit the mold and be equal to half the volume of the cylinder, but at an angle of 30° from the vertical. Additional dummy sections can be made by casting an epoxy-resin mortar against the machined dummy section contained in a specimen mold. Due precautions, such as waxing, shall be taken to prevent the bonding of the epoxy-resin mortar to the machined dummy section or the mold.

6.4 *Tamping Rod*—A 10-mm [3/8-in.] diameter tamping rod, as described in Practice C192/C192M.

6.5 *Apparatus for Mixing Epoxy-Resin Bonding System*—A glass, plastic, or metal container of approximately 0.1 L [3 oz.] capacity shall be used to hand-mix the bonding system. A tongue depressor or wooden stick of similar dimensions shall be used as a paddle.

6.6 *Testing Machine*—The testing machine shall be as described in Test Method C39/C39M.

6.7 *Moist Room*—The moist room shall conform to the requirements of Specification C511.

6.8 *Temperature-Conditioning Chambers*—Rooms or chambers in which the temperature is maintained appropriate to the class of the resin system being tested, in accordance with Specification C881/C881M.

#### 7. Materials

7.1 *Portland Cement Mortar Specimens* Laboratory conditions, materials, proportions, and procedures for mixing the portland-cement mortar shall be in accordance with Test Method C109/C109M. A Type III cement (Specification C150) shall be used.

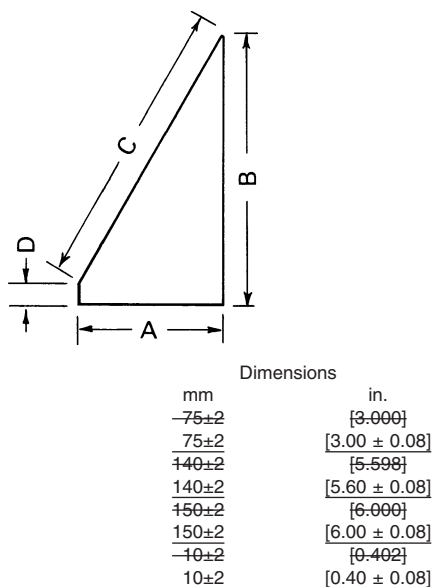

**FIG. 1 Dummy Section**