

**ISO/TC 17/SC 7**

**Date: 2023-03**

**ISO/FDIS 3887:2023(E)**

ISO/TC 17/SC 7

Secretariat: AFNOR

Date: 2023-05-10

## **Steels — Determination of the depth of decarburization**

*Aciers — Détermination de la profondeur de décarburation*

iTeh STANDARD PREVIEW  
(standards.iteh.ai)

<https://standards.iteh.ai/catalog/standards/iso/33079808-4cc8-4f6c-9a3b-ce048f9a62f8/iso-3887-2023>

**FDIS stage**

© ISO 2023

All rights reserved. Unless otherwise specified, or required in the context of its implementation, no part of this publication may be reproduced or utilized otherwise in any form or by any means, electronic or mechanical, including photocopying, or posting on the internet or an intranet, without prior written permission. Permission can be requested from either ISO at the address below or ISO's member body in the country of the requester.

ISO copyright office  
CP 401 • Ch. de Blandonnet 8  
CH-1214 Vernier, Geneva  
Phone: + 41 22 749 01 11  
~~Email~~**E-mail:** [copyright@iso.org](mailto:copyright@iso.org)  
Website: [www.iso.org](http://www.iso.org)~~www.iso.org~~

Published in Switzerland

## iTeh STANDARD PREVIEW (standards.iteh.ai)

ISO/FDIS 3887

<https://standards.iteh.ai/catalog/standards/sist/33079808-4cc8-4f6c-9a3b-ce048f9a62f8/iso-fdis-3887>

## Contents

Foreword .....	iv
1 Scope .....	1
2 Normative references.....	1
3 Terms and definitions .....	1
4 Sampling .....	2
5 Measuring methods.....	2
5.1 General .....	2
5.2 Metallographic method .....	3
5.2.1 General.....	3
5.2.2 Selection and preparation of the sample.....	3
5.2.3 Measurement .....	3
5.3 Methods for measuring the micro-indentation hardness .....	5
5.3.1 General.....	5
5.3.2 Selection and preparation of the sample.....	7
5.3.3 Measurement .....	7
5.4 Methods of determination of the carbon content.....	9
5.4.1 General.....	9
5.4.2 Chemical analysis .....	9
5.4.3 Spectrographic analysis.....	10
5.4.4 Interpretation of the results (chemical and spectrographic methods) .....	10
5.4.5 Electron probe microanalysis (EPMA) .....	10
5.4.6 Glow discharge optical emission spectrometry (GDOES) .....	10
6 Test report .....	11
Annex A (informative) Examples of typical decarburization microstructure.....	12

## Foreword

ISO (the International Organization for Standardization) is a worldwide federation of national standards bodies (ISO member bodies). The work of preparing International Standards is normally carried out through ISO technical committees. Each member body interested in a subject for which a technical committee has been established has the right to be represented on that committee. International organizations, governmental and non-governmental, in liaison with ISO, also take part in the work. ISO collaborates closely with the International Electrotechnical Commission (IEC) on all matters of electrotechnical standardization.

The procedures used to develop this document and those intended for its further maintenance are described in the ISO/IEC Directives, Part 1. In particular, the different approval criteria needed for the different types of ISO ~~documents~~document should be noted. This document was drafted in accordance with the editorial rules of the ISO/IEC Directives, Part 2 (see [www.iso.org/directives](http://www.iso.org/directives)).

~~Attention is drawn~~ISO draws attention to the possibility that ~~some of the~~ elementsimplementation of this document may ~~be~~involve the subjectuse of (a) patent(s). ISO takes no position concerning the evidence, validity or applicability of any claimed patent rights in respect thereof. As of the date of publication of this document, ISO had not received notice of (a) patent(s) which may be required to implement this document. However, implementers are cautioned that this may not represent the latest information, which may be obtained from the patent database available at [www.iso.org/patents](http://www.iso.org/patents). ISO shall not be held responsible for identifying any or all such patent rights. ~~Details of any patent rights identified during the development of the document will be in the Introduction and/or on the ISO list of patent declarations received (see -).~~

Any trade name used in this document is information given for the convenience of users and does not constitute an endorsement.

For an explanation ~~of~~ the voluntary nature of standards, the meaning of ISO specific terms and expressions related to conformity assessment, as well as information about ISO's adherence to the World Trade Organization (WTO) principles in the Technical Barriers to Trade (TBT), see [www.iso.org/iso/foreword.html](http://www.iso.org/iso/foreword.html) ~~the following URL:-~~.

This document was prepared by Technical Committee ISO/TC 17, *Steel*, Subcommittee SC 7, *Methods of testing (other than mechanical tests and chemical analysis)*, in collaboration with the European Committee for Standardization (CEN) Technical Committee CEN/TC 459, *Non-alloy carbon ferrous scrap categories and related specifications*, in accordance with the Agreement on technical cooperation between ISO and CEN (Vienna Agreement).

This fourth edition cancels and replaces the third edition (ISO 3887:2017), which has been revised. ~~The main change is as follows:~~

The main change is as follows:

- ~~—~~In [5.2.15.2.1](#) a ~~Note~~NOTE was added concerning the use of automatic image analysis.

Any feedback or questions on this document should be directed to the user's national standards body. A complete listing of these bodies can be found at [www.iso.org/members.html](http://www.iso.org/members.html).

# Steels — Determination of the depth of decarburization

## 1 Scope

This document defines the decarburization and specifies three methods of measuring the depth of decarburization of steel products.

## 2 Normative references

The following documents are referred to in the text in such a way that some or all of their content constitutes requirements of this document. For dated references, only the edition cited applies. For undated references, the latest edition of the referenced document (including any amendments) applies.

ISO 4545-1, *Metallic materials — Knoop hardness test — Part 1: Test method*

ISO 6507-1, *Metallic materials — Vickers hardness test — Part 1: Test method*

ISO 9556, *Steel and iron — Determination of total carbon content — Infrared absorption method after combustion in an induction furnace*

ISO 14594, *Microbeam analysis — Electron probe microanalysis — Guidelines for the determination of experimental parameters for wavelength dispersive spectroscopy*

ISO 14707, *Surface chemical analysis — Glow discharge optical emission spectrometry (GD-OES) — Introduction to use*

ISO 15349-2, *Unalloyed steel — Determination of low carbon content — Part 2: Infrared absorption method after combustion in an induction furnace (with preheating)*

## 3 Terms and definitions

For the purposes of this document, the following terms and definitions apply.

ISO and IEC maintain **terminological terminology** databases for use in standardization at the following addresses:

- ~~—~~ISO Online browsing platform: available at <https://www.iso.org/obp>
- ~~—~~IEC Electropedia: available at <https://www.electropedia.org/>

### 3.1 decarburization

reduction of carbon content from the surface zone of the steel

Note 1 to entry: A distinction is made between

- a) ~~a)~~ partial decarburization,  $d_3$ , measured as the distance from the point at which the carbon content exceeds the solubility limit in ferrite, becoming visible as, e.g. pearlite, to the point at which there is no more visible difference to the core carbon concentration, and
- b) ~~b)~~ complete decarburization, also called ferrite decarburization,  $d_1$ , measured as the distance between the surface of the product and the point up to which the carbon content is below the solubility limit of carbon in ferrite so that only ferrite is present.

Note 2 to entry: The depth of complete decarburization as described in b) is determined by examination of the microstructure.

## 3.2

### depth of functional decarburization

$d_2$

distance between the surface of the product and the point at which the carbon content or hardness is at the level where the performance of the product would be unaffected by a reduction in carbon content (i.e. at the minimum level specified in the product standard)

## 3.3

### depth of total decarburization

$d_4$

distance between the surface of the product and the point at which the carbon content is that of the unaffected core, the sum of the partial and the complete *decarburization* (3.1)  $d_3 + d_1$  being designated by the letters DD

EXAMPLE  $\pm DD = 0,08$  mm.

Note 1 to entry: Expressed in millimetres.

## 3.4

### depth profile of carbon content

curve indicating the relationship between the perpendicular distance from the surface of steel material and the carbon content

## 3.5

### depth profile of hardness

curve indicating the relationship between the perpendicular distance from the surface of steel material and the hardness

## 4 Sampling

ISO/FDIS 3887

<https://standards.iteh.ai/catalog/standards/sist/33079808-4cc8-4f6c-9a3b-ce048f9a62f8/iso-3887>

Samples should be taken at locations that are representative of the bulk specimen. The location and number of samples taken depend on the nature of the material to be tested and are defined by agreement between the parties concerned.

Specimens for the metallographic methods or micro-indentation hardness tests or electron probe microanalysis should be cut from the bulk specimen perpendicular to the longitudinal axis of the product so that measurements are made on a transverse plane. This procedure permits the determination of the variation of decarburization around the periphery of the specimen. Unless otherwise specified, the corner parts which can generate abnormal decarburization shall not be included. For specimens up to about 2,5 cm diameter, the entire cross-section is polished and examined. For larger cross-sections, one or more specimens shall be prepared to assess variations in surface decarburization. The sampling scheme for large sections should be determined by agreement between the parties concerned.

Specimens for chemical analytical methods shall be of sufficient length so that the weight of incremental turnings is adequate for chemical analysis or the size of milled surfaces is large enough for sparking yet small enough to fit in the specimen holder.

## 5 Measuring methods

### 5.1 General

The choice of the method and its accuracy depend on the degree of decarburization, the microstructure, the carbon content of the product examined and the shape of the component.

The usual methods employed on finished products are as follows:

- metallographic method (see 5.2.2);

- ~~—~~ method for measuring the micro-indentation hardness (Vickers or Knoop) for steels in the hardened or quenched and tempered condition (see [5.35.3](#));
- ~~—~~ method for the determination of the carbon content by chemical analysis (see [5.4.25.4.2](#)), spectrographic analysis (see [5.4.35.4.3](#)), electron probe microanalysis (EPMA) (see [5.4.55.4.5](#)), or glow discharge optical emission spectrometry (GDOES) (see [5.4.65.4.6](#)).

The sample shall be examined in the as-delivered condition. Nevertheless if, by agreement between the parties concerned, a supplementary heat treatment is applied, every precaution shall be taken to prevent changes in mass percentage and/or in the distribution of carbon, e.g. a small sample, a short austenitization time, a neutral atmosphere.

The measuring method shall be agreed upon in writing by the parties concerned, unless it is defined in the product standard. In the absence of any agreement or requirement in a product standard, the metallographic method should be used.

## 5.2 Metallographic method

### 5.2.1 General

Unless otherwise specified, this method shall only be applied in situations where changes in the carbon content are reflected by resulting variations in microstructure.

This method is especially valid for steels showing an annealed, normalized, as-rolled or as-forged structure. It may apply, with reservations, for products showing a hardened or tempered structure where the interpretation of the structural variations becomes difficult.

**Note** NOTE Automatic image analysis can be used to measure the depth of decarburization. Preferably, the accuracy of the methods is previously proven by an extensive cross correlation.

### 5.2.2 Selection and preparation of the sample

The metallographic polishing, carried out by applying the usual methods, shall not round the edges. In order to achieve this, the sample may be mounted or held in a clamp, and the surface of the product may, if necessary, be protected by a metallic deposit obtained by electroless or electrolytic plating. Automatic/semi-automatic preparation techniques should be used, where possible.

Etching in a solution of 1,5 % to 4 % nitric acid in ethanol (nital) or 2 % to 5 % picric acid in ethanol (picral) will reveal the structure of the steel.

### 5.2.3 Measurement

As a rule, the reduction in the carbon content can be determined for the following:

- a) ~~a)~~ ferrite and pearlite: from the decrease in the amount of pearlite;
- b) ~~b)~~ pearlite and hypereutectoidally developed carbides: from the decrease in the amount of hypereutectoidally developed carbides and/or of pearlite;
- c) ~~c)~~ ferrite matrix with dispersed carbides: from the decrease in the amount of carbides in the ferrite matrix.

This method can also be applied for assessing changes in the microstructure if the carbon content leads to clear changes in the microstructure, e.g. for hardened or quenched and tempered microstructures, but only if a distinct boundary which is decisive for the depth of decarburization exists within the characteristic structure. Examples of typical decarburization microstructure are given in [Annex A](#).

The distance from the surface to the point at which the structure does not differ from that of the core shall be measured (total decarburization). The measurement shall be conducted using suitably calibrated equipment.

The choice of magnification depends on the depth of decarburization and shall be chosen by the assessor unless otherwise agreed between the parties concerned. The maximum magnification that allows the full extent of decarburization to be viewed should be adopted. A magnification of  $\times 100$  is recommended as a useful magnification for the majority of instances.

A preliminary examination of the whole surface at low magnification ensures that any great variation in the depth of decarburization along the periphery will be observed for further evaluation.

The deepest uniform decarburization zone is selected from the preliminary examination of the surface of the section. One of two methods of measurement should be used. The choice of the measurement method shall be in accordance with the agreement between the parties concerned.

- — The worst field method is the simplest method and is adequate for many purposes. One measurement of the depth of decarburization is conducted and reported at the deepest uniform decarburization zone.
- — The average method is the alternative method. Beginning at the deepest uniform decarburization zone, the first measurement point, the surface is divided into parts of equal size, at the ends of which the depth of decarburization is also measured. Unless otherwise agreed, four individual measured values are determined. The depth of total decarburization of the sample is defined as the average of these measurements. Measuring points that are affected by surface defects are not taken into account when determining the average.

The various bands of decarburization are shown schematically in [Figure 1](#). The boundaries separating the various types of decarburization are shown as hatched bands with the width of the band illustrating the practical variability in measurements due to the uncertainty of interpretation.

If the product has undergone a process involving carburization, the definition of the “core” shall form the subject of an agreement between the parties concerned.

The permissible depth of decarburization shall be specified in the appropriate standard covering the product or shall be the subject of an agreement between the parties concerned.

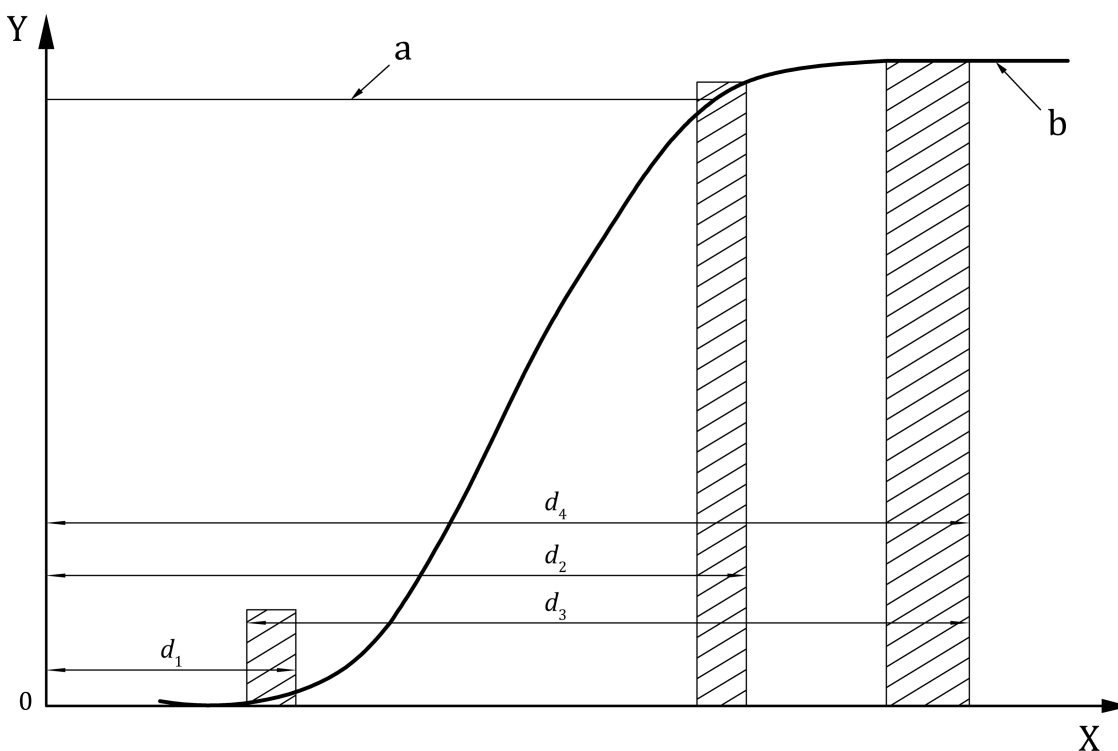



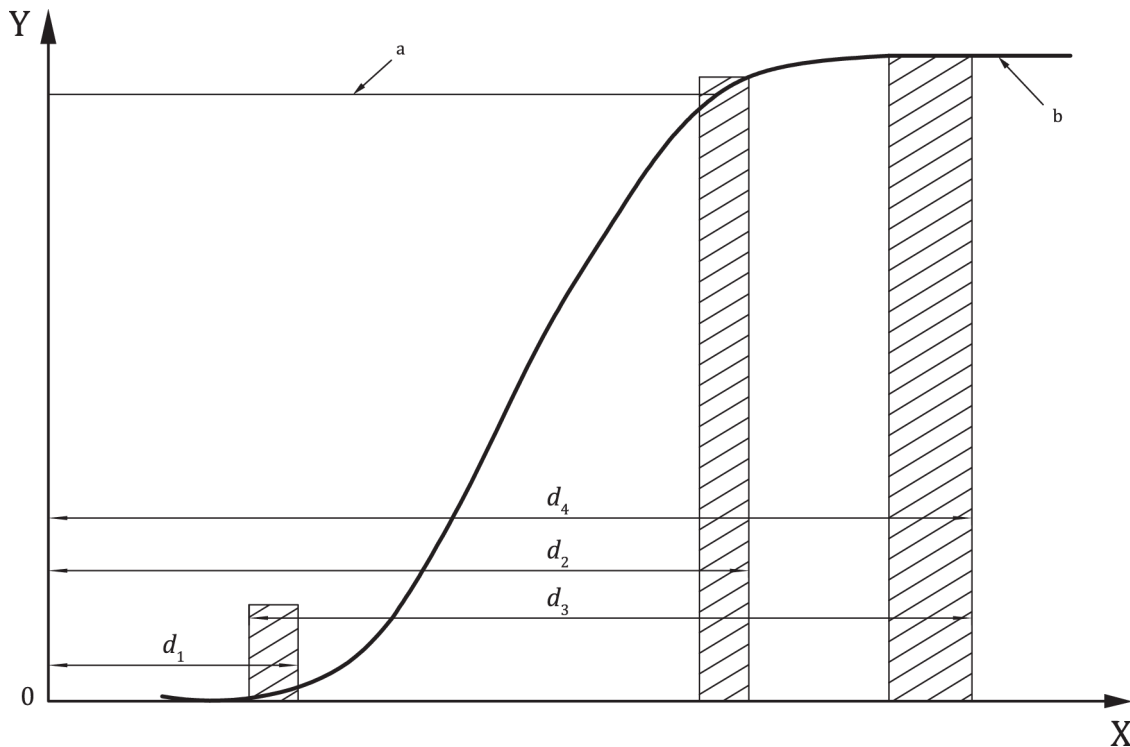

#### Key

$\overset{a}{X}$  distance from surface in the product standard. Minimum carbon content specified in the product standard.  $d_1$  complete decarburization

$\overset{b}{Y}$  Core carbon content.  $d_2$  functional decarburization

$\overset{X}{a}$  Minimum carbon content specified in the product standard. distance from surface.  $d_3$  partial decarburization

$\overset{Y}{b}$  Core carbon content.  $d_4$  total decarburization

NOTE  $\div$ —The depth of complete decarburization as described in  $d_1$  is determined by examination of the microstructure.

**Figure 1 — Depth profile of carbon content: schematic representation for a typical decarburized steel**

## 5.3 Methods for measuring the micro-indentation hardness

### 5.3.1 General

The methods under consideration are that of Vickers, in accordance with ISO 6507--1, and of Knoop, in accordance with ISO 4545--1.

Each method consists of determining the depth profile of the micro-indentation hardness on a cross-section of the product along a line perpendicular (see [Figure 2](#)) or oblique (see [Figure 3](#)) to the surface. The perpendicular line is convenient for the measurement of large and medium depths of decarburization and the oblique line for medium and small depths. In the case of the perpendicular line, finer measuring intervals can be obtained if a zigzag line is used.

This technique applies only to hypoeutectoid steels in the hardened, tempered or heat-treated condition, and to decarburized zones that are within a hardened zone, in order to avoid the occurrence of variations in hardness due to an imperfect penetration. The technique becomes inaccurate for low-carbon steels.

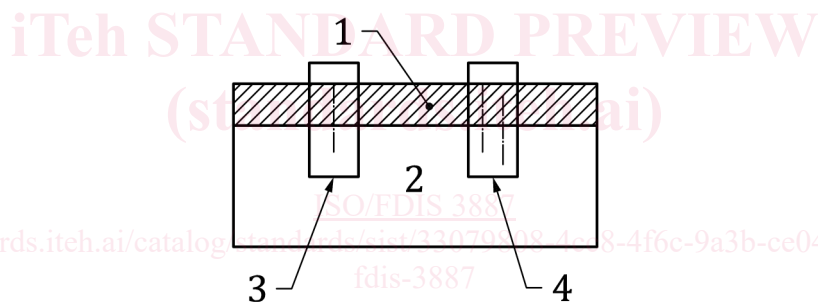
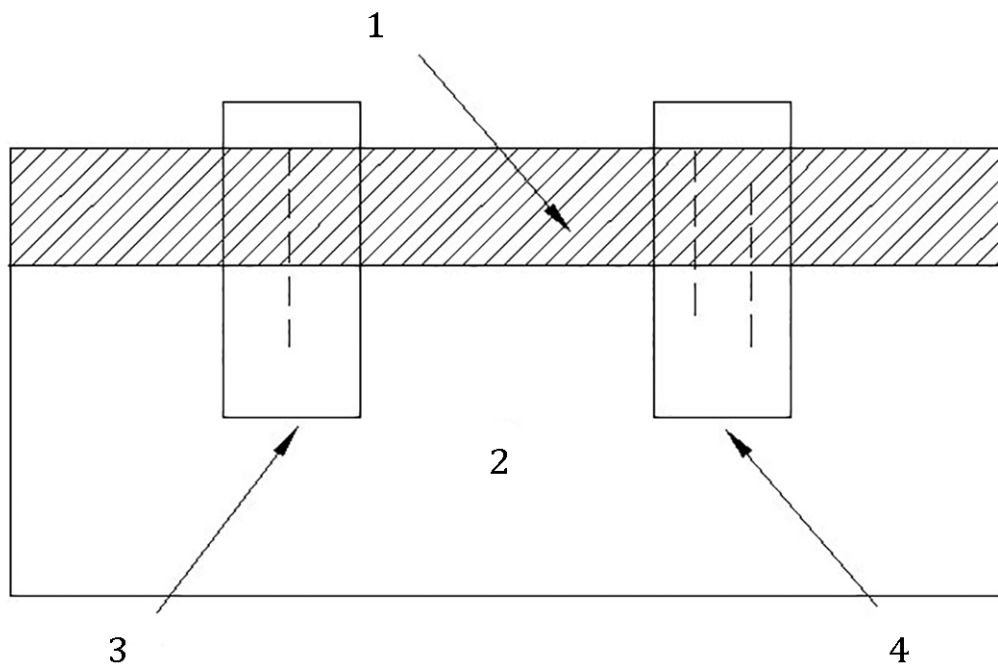

**Key**

- 1 decarburization
- 2 core material
- 3 one straight line
- 4 zigzag line

NOTE The dashed lines indicate the measurement lines.

**Figure 2 — Schema of measurement on a cross-section of the product along a line perpendicular to the surface**