



**SLOVENSKI STANDARD**  
**SIST ISO 3380:1998**

**01-april-1998**

---

I gb^Y!^I [ cHUj`^Ub^Y^hYa dYfUhi fY\_f Yb^U

Leather -- Determination of shrinkage temperature

Cuir -- Détermination de la température de rétraction

ITEH STANDARD PREVIEW  
(standards.iteh.ai)

**Ta slovenski standard je istoveten z: ISO 3380:1975**

[SIST ISO 3380:1998](https://standards.iteh.ai/catalog/standards/sist/f00391de-7ca9-41cd-86b2-1d5a105b1743/sist-iso-3380-1998)

<https://standards.iteh.ai/catalog/standards/sist/f00391de-7ca9-41cd-86b2-1d5a105b1743/sist-iso-3380-1998>

**ICS:**

59.140.30      Usnje in krzno      Leather and furs

**SIST ISO 3380:1998**

**en**

**iTeh STANDARD PREVIEW**  
**(standards.iteh.ai)**

SIST ISO 3380:1998

<https://standards.iteh.ai/catalog/standards/sist/f00391de-7ca9-41cd-86b2-1d5a105b1743/sist-iso-3380-1998>

---

**INTERNATIONAL STANDARD**



**3380**

---

INTERNATIONAL ORGANIZATION FOR STANDARDIZATION • МЕЖДУНАРОДНАЯ ОРГАНИЗАЦИЯ ПО СТАНДАРТИЗАЦИИ • ORGANISATION INTERNATIONALE DE NORMALISATION

---

## **Leather — Determination of shrinkage temperature**

*Cuir — Détermination de la température de rétraction*

First edition — 1975-12-15

**iTeh STANDARD PREVIEW**  
**(standards.iteh.ai)**

[SIST ISO 3380:1998](https://standards.iteh.ai/catalog/standards/sist/f00391de-7ca9-41cd-86b2-1d5a105b1743/sist-iso-3380-1998)

<https://standards.iteh.ai/catalog/standards/sist/f00391de-7ca9-41cd-86b2-1d5a105b1743/sist-iso-3380-1998>

---

UDC 675 : 620.172.23

Ref. No. ISO 3380-1975 (E)

**Descriptors** : leather, tests, physical tests, shrinkage temperature.

**FOREWORD**

ISO (the International Organization for Standardization) is a worldwide federation of national standards institutes (ISO Member Bodies). The work of developing International Standards is carried out through ISO Technical Committees. Every Member Body interested in a subject for which a Technical Committee has been set up has the right to be represented on that Committee. International organizations, governmental and non-governmental, in liaison with ISO, also take part in the work.

Draft International Standards adopted by the Technical Committees are circulated to the Member Bodies for approval before their acceptance as International Standards by the ISO Council.

International Standard ISO 3380 was drawn up by Technical Committee ISO/TC 120, *Leather*, and circulated to the Member Bodies in May 1974.

It has been approved by the Member Bodies of the following countries :

Australia	Germany	South Africa, Rep. of
Brazil	Hungary	Spain
Bulgaria	India	Thailand
Canada	Iran	Turkey
Chile	Ireland	United Kingdom
Czechoslovakia	Israel	U.S.S.R.
Egypt, Arab Rep. of	Poland	Yugoslavia
Ethiopia	Portugal	
France	Romania	

No Member Body expressed disapproval of the document.

This International Standard is based on method IUP/16 of the International Union of Leather Chemists' Societies.

# Leather – Determination of shrinkage temperature

## 1 SCOPE AND FIELD OF APPLICATION

This International Standard specifies a method for the determination of the shrinkage temperature of leather.

It is applicable to any type of leather with a shrinkage temperature below that of boiling water.

## 2 REFERENCE

ISO 2589, *Leather – Physical testing – Measurement of thickness.*

## 3 PRINCIPLE

Slow heating of a test piece in water. Measurement of the temperature at which a sudden shrinkage occurs.

NOTE – The shrinkage temperature is characteristic of the tannage.

## 4 APPARATUS

4.1 The apparatus used for wetting the specimen shall consist of the following :

4.1.1 **Desiccator** or other glass vessel which can be evacuated.

4.1.2 **Vacuum pump** capable of reducing the absolute pressure in the vessel to less than 4 kPa within 2 min.

4.1.3 **Test tube** in which the specimen can be immersed in 5 ml of water.

The test tube shall be supported approximately upright in the vessel (4.1.1) during its evacuation (see 8.1 and 8.2).

4.2 The apparatus used for the shrinkage temperature measurement shall consist of the following parts (see the figure) :

4.2.1 **Glass beaker**, capacity 500 ml and internal diameter  $70 \pm 2$  mm, standing on the platform of a magnetic stirrer.

4.2.2 **Brass tube**, internal diameter 4 mm, closed at the bottom, with a rod which keeps it in position in the beaker, and a 1,5 mm diameter pin which passes through the lower hole in the test piece and is  $30 \pm 5$  mm above the bottom of the beaker.

4.2.3 **Circular scale**, diameter 45 mm, marked at the rim with divisions of 1 mm, and having a light pointer, balanced in all positions, rigidly attached to a 10 mm diameter pulley.

iTeh STANDARD PREVIEW  
(standards.iteh.ai)

SIST ISO 3380:1998

<https://standards.iteh.ai/catalog/standards/sist/f00391e-7ca9-41cd-8662-1d5a105b1743/sist-iso-3380-1975>

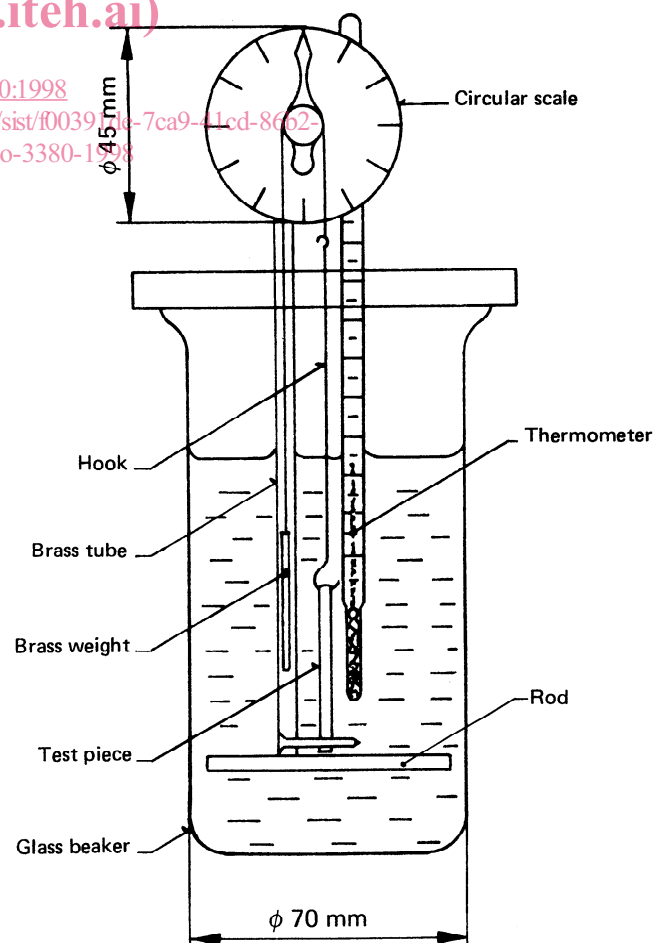

FIGURE – Apparatus for shrinkage temperature measurement

## ISO 3380-1975 (E)

**4.2.4 Hook**, made of copper wire; one end passes through the hole at the top of the test piece, the other is attached to a thread which passes over the pulley and supports a brass weight in the brass tube (4.2.2).

The pulley and circular scale shall be attached rigidly to the brass tube (4.2.2), so that changes of length of the test piece cause rotation of the pointer over the scale.

The pulley shall be free to move in its bearing with minimum friction, and the mass of the brass weight shall be 3 g more than that of the hook, so that the tension in the test piece is somewhat more than 0,03 N.

**4.2.5 Thermometer** graduated in degrees Celsius, supported by a disk which also supports the brass tube (4.2.2) and the parts attached to it. The bulb of the thermometer shall be close to the middle of the test piece. The hook shall move freely through a hole in the disk without touching it.

**4.2.6 Electric heater**, 80 to 100 W, preferably of the type having a glass or silica sheath (not shown in the figure).

The heater shall be supported in the beaker so that its lower end is not more than 30 mm from the bottom and shall be controllable to give a rate of heating of approximately 2 °C per minute when the beaker contains 350 ml of water.

NOTE – Patterns of apparatus other than that described in 4.2 and illustrated in the figure may be used, provided that the same essential features are present and that the results obtained are not significantly affected by the alternative design of apparatus.

## 5 TEST PIECES

**5.1** Measure the thickness of the leather in accordance with ISO 2589.

If the thickness is less than 3 mm, cut the test piece as a rectangle of length 50 mm and breadth 3 mm; if the thickness exceeds 3 mm, cut it as a rectangle 50 mm by 2 mm.

**5.2** To allow the test piece to be supported, punch a small hole 5 mm from each end and on a line parallel to, and equidistant from, the sides of the rectangle.

## 6 REQUIREMENTS FOR TEMPERATURE MEASUREMENTS

The thermometer used for temperature measurements shall be one that has been shown, by calibration against a standard thermometer, to have no error exceeding 0,5 °C at any point in the temperature range 50 to 105 °C.

Before using the apparatus, ensure that the stirring is adequate by testing as follows :

Put into the apparatus a piece of leather to act as a dummy test piece, and support two thermometers, A and B, which have been calibrated against one another, so that the mid-points of their bulbs are adjacent to, and at the same

level as, the top and bottom of the specimen. Put in 350 ± 10 ml of water and switch on the stirrer and heater, raising the temperature at approximately 2 °C per minute. Read both thermometers every 3 min and calculate at each of these times the temperature difference between the top and bottom of the specimen (making allowance for the differences between the thermometers as shown by their calibration).

The stirring is adequate if none of the calculated temperature differences exceeds 1,0 °C.

## 7 PROCEDURE

**7.1** Put 5 ml of distilled water at 20 ± 2 °C into the test tube (4.1.3), and immerse the test piece in it, with a glass bead or piece of glass rod on top of the test piece if this is necessary to keep it immersed.

**7.2** Stand the test tube in the vessel (4.1.1) which is to be evacuated. Evacuate the vessel, and maintain the absolute pressure in it below 4 kPa for 1 to 2 min.

**7.3** Allow air to enter the vessel. Stop the pump, and keep the test piece immersed for at least 1 h before using it for measurements of the shrinkage temperature.

**7.4** Attach the top end of the test piece to the hook (4.2.4) and its lower end to the pin (see 4.2.2 and figure).

**7.5** Put into the beaker (4.2.1) 350 ± 10 ml of warmed distilled water. For a test piece whose shrinkage temperature is known to be or suspected to be below 60 °C (see 8.5) use water of a temperature at least 10 °C below the expected shrinkage temperature. (For the procedure with leathers having lower shrinkage temperatures, see 7.7.) Heat the water and maintain the rate of rise of temperature as near as possible to 2 °C per minute.

**7.6** At intervals of 30 s, note the temperature and the corresponding reading of the pointer. Continue these observations until the test piece shrinks considerably or the water boils vigorously. If the water boils, record the temperature of boiling (see 8.4).

By inspection of the tabulated results, or by use of a graph of pointer readings versus temperature, find the temperature at which the test piece has shrunk to such an extent as to move the pointer half a division from the position corresponding to the maximum length of the test piece. Record this temperature as the shrinkage temperature of the test piece (see 8.3).

**7.7** If the shrinkage temperature measured as above is not at least 5 °C higher than the temperature at which the water was put into the beaker, discard the result, wet another test piece as described in 7.1 to 7.3 and repeat the procedure described in 7.4 to 7.7.

## 8 NOTES ON PROCEDURE

**8.1** If the leather fibres have hydrophobic surfaces, water uptake and wetting of the leather may be slow if the leather is merely immersed in water. Reduction of pressure removes air from the leather and restoration of pressure forces water into it; this results in rapid wetting.

**8.2** A test tube of internal diameter between 8 and 11 mm is suitable.

**8.3** Even the slight tension of 0,03 N is sufficient to cause some specimens to extend, and apparent slight changes of length of the specimen may be caused by changes of the dimensions of the apparatus, by flexing of the test piece due to currents in the water, etc. It is necessary to tabulate or plot pointer readings against temperature in order to be able to differentiate between movements of the pointer caused in these ways and the beginning of the larger and progressively increasing movement due to the shrinkage of the test piece.

The shrinkage temperature is taken as that temperature at which a small, but finite, shrinkage has occurred, because there is often difficulty in deciding when shrinkage begins. The pointer movement of half a division corresponds to a contraction of the test piece by about 0,3 % of its length.

**8.4** The method described above is not applicable to test pieces with shrinkage temperatures exceeding the temperature of boiling water. If it is necessary to measure the shrinkage temperatures of such leathers, it is

recommended that the apparatus used should contain water under pressure and not a mixture (for example of water and glycerol).

**8.5** Nearly all leathers have shrinkage temperatures above 60 °C but there are a few which shrink at lower temperatures.

## 9 EXPRESSION OF RESULTS

If the shrinkage temperature (7.6) is reached before the water boils, express the test result as the value of this temperature, to the nearest degree Celsius.

If the water boils before the shrinkage temperature is reached, state that the shrinkage temperature is above the boiling point of the water and report also the recorded boiling temperature.

## 10 TEST REPORT

The test report shall include the following particulars :

- a) a reference to this International Standard;
- b) the test result;
- c) any deviation from the prescribed method;
- d) whether the test piece came from a whole hide, bend, shoulder or belly;
- e) the reference of the lot.