



Designation: D5875/D5875M – 13

# Standard Guide for Use of Cable-Tool Drilling and Sampling Methods for Geoenvironmental Exploration and Installation of Subsurface Water-Quality Monitoring Devices<sup>1</sup>

This standard is issued under the fixed designation D5875/D5875M; the number immediately following the designation indicates the year of original adoption or, in the case of revision, the year of last revision. A number in parentheses indicates the year of last reapproval. A superscript epsilon ( $\epsilon$ ) indicates an editorial change since the last revision or reapproval.

## 1. Scope\*

1.1 This guide covers cable-tool drilling and sampling procedures used for geoenvironmental exploration and installation of subsurface water-quality monitoring devices.

1.2 Several sampling methods exist for obtaining samples from drill holes for geoenvironmental purposes and subsequent laboratory testing. Selection of a particular drilling procedure should be made on the basis of sample types needed and geohydrologic conditions observed at the study site.

1.3 Drilling procedures for geoenvironmental exploration often will involve safety planning, administration and documentation. This guide does not purport to specifically address exploration and site safety.

NOTE 1—This guide does not include considerations for geotechnical site characterizations.

1.4 The values stated in either SI units or inch-pound units are to be regarded separately as standard. The values stated in each system may not be exact equivalents; therefore, each system shall be used independently of the other. Combining values from the two systems may result in non-conformance with the standard.

1.5 *This standard does not purport to address all of the safety concerns, if any, associated with its use. It is the responsibility of the user of this standard to establish appropriate safety and health practices and determine the applicability of regulatory limitations prior to use.*

1.6 *This guide offers an organized collection of information or a series of options and does not recommend a specific course of action. This document cannot replace education or experience and should be used in conjunction with professional judgment. Not all aspects of this guide may be applicable in all circumstances. This ASTM standard is not intended to represent or replace the standard of care by which the adequacy of*

*a given professional service must be judged, nor should this document be applied without consideration of a project's many unique aspects. The word "Standard" in the title of this document means only that the document has been approved through the ASTM consensus process.*

## 2. Referenced Documents

### 2.1 ASTM Standards:<sup>2</sup>

D653 Terminology Relating to Soil, Rock, and Contained Fluids

D1452 Practice for Soil Exploration and Sampling by Auger Borings

D1586 Test Method for Penetration Test (SPT) and Split-Barrel Sampling of Soils

D1587 Practice for Thin-Walled Tube Sampling of Soils for Geotechnical Purposes

D3550 Practice for Thick Wall, Ring-Lined, Split Barrel, Drive Sampling of Soils

D3740 Practice for Minimum Requirements for Agencies Engaged in Testing and/or Inspection of Soil and Rock as Used in Engineering Design and Construction

D4428/D4428M Test Methods for Crosshole Seismic Testing

D5088 Practice for Decontamination of Field Equipment Used at Waste Sites

## 3. Terminology

### 3.1 Definitions:

3.2 For definitions of general technical terms used within this guide, refer to Terminology D653.

### 3.3 Definitions of Terms Specific to This Standard:

3.3.1 *bailer*—a long, narrow bucket, made from a piece of large-diameter pipe with a dart valve in the bottom, used to remove cuttings from the borehole.

3.3.2  *bentonite*—the common name for drilling-fluid additives and well-construction products consisting mostly of

<sup>1</sup> This guide is under the jurisdiction of ASTM Committee D18 on Soil and Rock and is the direct responsibility of Subcommittee D18.21 on Groundwater and Vadose Zone Investigations.

Current edition approved Aug. 1, 2013. Published September 2013. Originally approved in 1995. Last previous edition approved in 2006 as D5875 – 95 (2006). DOI: 10.1520/D5875/D5875M-13.

<sup>2</sup> For referenced ASTM standards, visit the ASTM website, www.astm.org, or contact ASTM Customer Service at service@astm.org. For *Annual Book of ASTM Standards* volume information, refer to the standard's Document Summary page on the ASTM website.

\*A Summary of Changes section appears at the end of this standard

naturally occurring montmorillonite. Some bentonite products have chemical additives which may affect water-quality analyses.

3.3.3 *bentonite granules and chips*—irregularly-shaped particles of bentonite (free from additives) that have been dried and separated into a specific size range.

3.3.4 *bentonite pellets*—roughly spherical- or disc-shaped units of compressed bentonite powder (some pellet manufacturers coat the bentonite with chemicals that may affect the water-quality analysis).

3.3.5 *collar*—the section of a drill tool between the wrench square and the pin or box joint.

3.3.6 *dart valve*—a type of valve used on a bailer, that opens when the bailer drops through the cuttings at the bottom of the borehole.

3.3.7 *drill bit*—the steel tool on the lower end of the string of tools which does the actual drilling; shaped to perform the operations of penetration, reaming, crushing, and mixing.

3.3.8 *drill hole*—a cylindrical hole advanced into the subsurface by mechanical means. Also known as a borehole or boring.

3.3.9 *drill stem*—a steel tool composed of a round bar of steel with a pin joint at its upper end and a box joint at its lower end that is placed below the jars in a string of drilling tools to furnish the necessary weight to the tool string.

3.3.10 *drill string*—the complete cable-tool drilling assembly including bit, drill rods and connector assemblies (subs). The total length of this assembly is used to determine drilling depth by referencing the position of the top of the string to a datum near the ground surface.

3.3.11 *drive shoe*—a forged- or machined-steel collar either a threaded- or drop-type attached to the upper joint of casing to protect the casing threads during driving operations.

3.3.12 *filter pack*—also known as a gravel pack or primary filter pack in the practice of monitoring-well installations. The gravel pack is usually granular material, having specified grain-size characteristics, that is placed between a monitoring device and the borehole wall. The basic purpose of the filter pack or gravel envelope is to act as a non-clogging filter when the aquifer is not suited to natural development or a formation stabilizer when the aquifer is suitable for natural development.

3.3.12.1 *Discussion*—Under most circumstances a clean, quartz sand or gravel should be used. In some cases a pre-packed screen may be used.

3.3.13 *grout packer*—a reusable inflatable or expandable annular plug that is attached to a tremie pipe, usually positioned immediately above the discharge end of the pipe.

3.3.14 *intermittent sampling devices*—usually barrel-type samplers that are driven below the bottom of a borehole with drill rods or with a wireline system to lower, drive, and retrieve the sampler following completion of an increment of drilling. The user is referred to the following standards relating to suggested sampling methods and procedures: Practice **D1452**, Test Method **D1586**, Practice **D3550**, and Practice **D1587**.

3.3.15 *in-situ testing devices*—sensors or probes, used to obtain mechanical- or chemical-test data, that are typically pushed, rotated or driven below the bottom of a borehole following completion of an increment of drilling. However, some *in-situ testing devices* (such as electronic pressure transducers, gas-lift samplers, tensiometers, and so forth) may require lowering and setting of the device(s) in pre-existing boreholes by means of a suspension line or a string of lowering rods or pipes. Centralizers may be required to correctly position the device(s) in the borehole.

3.3.16 *jars*—a tool composed of two connected links or reins with vertical play between them (see **Fig. 1** and Ref **(1)**).<sup>3</sup> Drilling jars have a stroke of 230 to 460 mm [9 to 18 in.] whereas, fishing jars have a stroke of 460 to 900 mm [18 to 36 in.]. Jars permit a sudden upward load or shock to loosen a string of tools stuck in the borehole.

3.3.17 *sand pump*—bailer made of tubing with a hinge-flap valve and a plunger that works inside the barrel. It is used in sand and gravel where the dart-valve bailer will not pick up the materials adequately.

3.3.18 *spear*—a fishing tool used when the drilling line or sand line breaks leaving the drilling tools or bailer in the hole with the line on top of the lost tools.

3.3.19 *swivel socket*—a socket that permits the tool string to spin or turn during the drilling action (sometimes referred to as a rope socket).

3.3.20 *subsurface water-quality monitoring device*—an instrument placed below ground surface to obtain a sample for analysis of the chemical, biological or radiological characteristics of subsurface pore water or to make in-situ measurements.

3.3.21 *wrench square*—a square section on any drilling tool by which the joints are set up or broken.

## 4. Significance and Use

4.1 Cable-tool rigs (also referred to as churn rigs, water-well drilling rigs, spudders, or percussion rigs) are used in the oil fields and in the water-well industry. The Chinese developed the percussion method some 4000 years ago.

4.2 Cable-tool drilling and sampling methods may be used in support of geoenvironmental exploration and for installation of subsurface water-quality monitoring devices in both unconsolidated and consolidated materials. Cable-tool drilling and sampling may be selected over other methods based on its advantages, some of which are its high mobility, low water use, low operating cost, and low maintenance. Cable-tool drilling is the most widely available casing-advancement method that is restricted to the drilling of unconsolidated materials and softer rocks.

4.2.1 The application of cable-tool drilling and sampling to geoenvironmental exploration may involve sampling unconsolidated materials. Depth of drill holes may exceed 900 m [3000 ft] and may be limited by the length of cable attached to

<sup>3</sup> The boldface numbers given in parentheses refer to a list of references at the end of the text.



1. Drill Stem.
2. Regular pattern bit.
3. Star or four-wing bit.
4. Jars.
5. Wrench for tightening drive clamps.
6. Drive clamps.

FIG. 1 Drilling Tools

the bull reel. However, most drill holes for geoenvironmental exploration rarely are required to go that deep. Rates for cable-tool drilling and sampling can vary from a general average of as much as 7.5 to 9 m/h [25 to 30 ft/h] including setting 200 mm [8 in.] diameter casing to considerably less than that depending on the type(s) of material drilled, and the type and condition of the equipment and rig used.

NOTE 2—As a general rule, cable-tool rigs are used to sample the surficial materials, and to set surface casing in order that rotary-core rigs subsequently may be set up on the drill hole to core drill hard rock if coring is required.

NOTE 3—The quality of the result produced by this standard is dependent on the competence of the personnel performing it, and the suitability of the equipment and facilities used. Agencies that meet the criteria of Practice D3740 are generally considered capable of competent and objective testing/sampling/inspection/etc. Users of this standard are cautioned that compliance with Practice D3740 does not in itself assure

reliable results. Reliable results depend on many factors; Practice D3740 provides a means of evaluating some of those factors.

4.2.2 The cable-tool rig may be used to facilitate the installation of a subsurface water-quality monitoring device(s) including in-situ testing devices. The monitoring device(s) may be installed through the casing as the casing is removed from the borehole. The sand line can be used to raise, lower, or set in-situ testing device(s), or all of these. If necessary, the casing may also be left in the borehole as part of the device.

NOTE 4—The user may install a monitoring device within the same borehole wherein sampling, in-situ, or pore-fluid testing, or coring was performed.

## 5. Apparatus

5.1 Cable-tool rigs (see Fig. 2) have a string of drill tools with a drive clamp (see Fig. 1 and Ref (2)) on the drill string

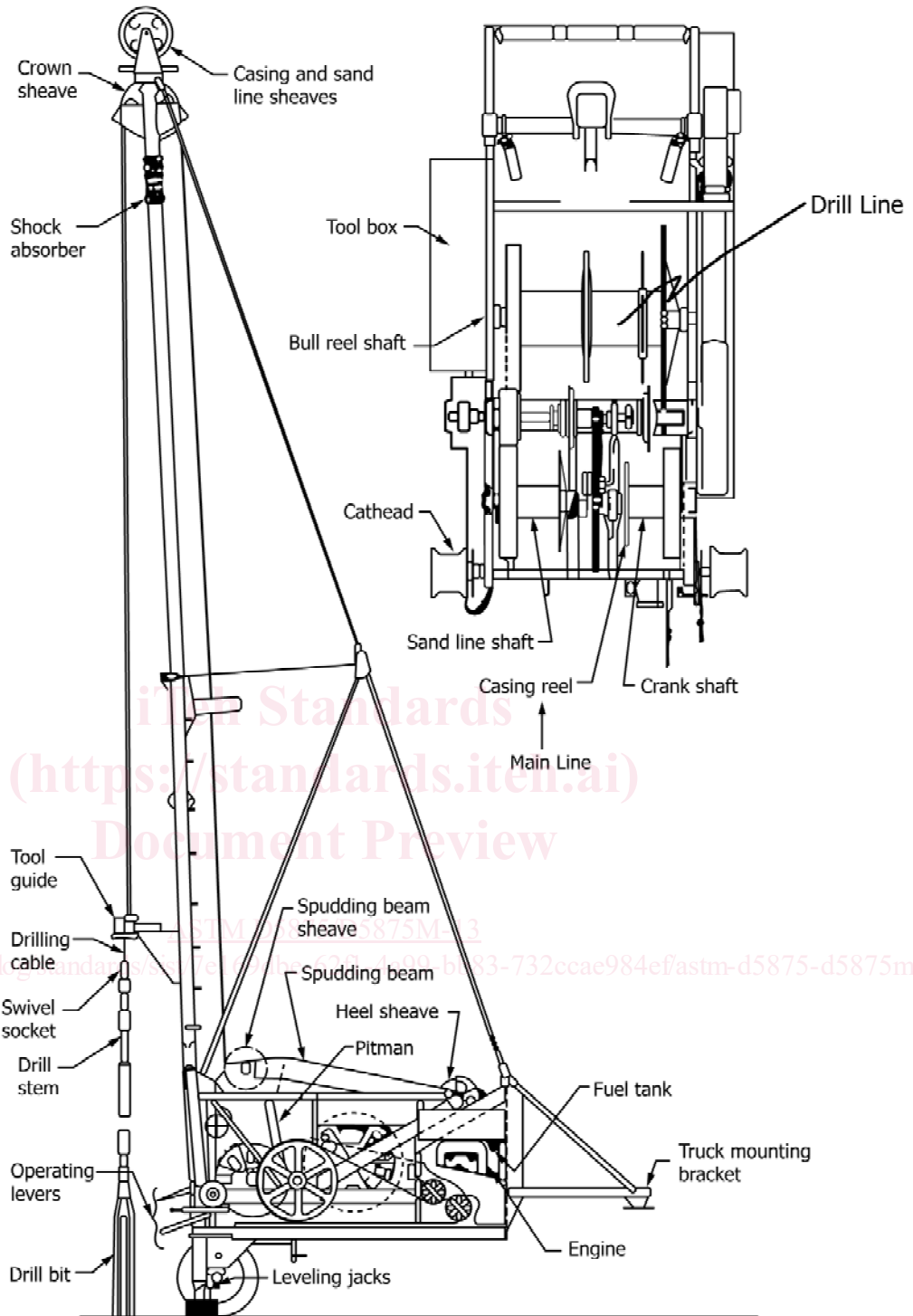

FIG. 2 Diagram of a Cable Tool Drilling System

connected by wire rope that periodically can be hoisted and allowed to “fall” for percussion drilling in unconsolidated and consolidated materials and for driving/retrieving casing. The full string of drilling equipment consists of drill bit (see Fig. 1 and Ref (3)—Regular bit used for all-around general drilling and, Ref (4)—Star bit used for chopping and breaking hard materials and rock), drilling jars (optional), and a drill stem

(see Fig. 1 and Ref (5)), with a swivel socket (see Fig. 2) connected by a wire rope fastened to a drum called a bull reel that raises and lowers the drilling tools and permits percussion drilling either by crushing the material or by drive sampling. The spudding beam, commonly referred to as the walking beam, that is driven by the pitman and crank, imparts a reciprocating motion to the drilling line.