

FINAL
DRAFT

INTERNATIONAL
STANDARD

ISO/FDIS
5211

ISO/TC 153

Secretariat: AFNOR

Voting begins on:
2023-05-16

Voting terminates on:
2023-08-08

Industrial valves — Part-turn actuator attachments

Robinetterie industrielle — Raccordement des actionneurs à fraction de tour

iTeh STANDARD PREVIEW
(standards.iteh.ai)

ISO/FDIS 5211

<https://standards.iteh.ai/catalog/standards/sist/254f808c-e149-421e-af2b-a70d9d51c8fe/iso-fdis-5211>

ISO/CEN PARALLEL PROCESSING

RECIPIENTS OF THIS DRAFT ARE INVITED TO SUBMIT, WITH THEIR COMMENTS, NOTIFICATION OF ANY RELEVANT PATENT RIGHTS OF WHICH THEY ARE AWARE AND TO PROVIDE SUPPORTING DOCUMENTATION.

IN ADDITION TO THEIR EVALUATION AS BEING ACCEPTABLE FOR INDUSTRIAL, TECHNOLOGICAL, COMMERCIAL AND USER PURPOSES, DRAFT INTERNATIONAL STANDARDS MAY ON OCCASION HAVE TO BE CONSIDERED IN THE LIGHT OF THEIR POTENTIAL TO BECOME STANDARDS TO WHICH REFERENCE MAY BE MADE IN NATIONAL REGULATIONS.



Reference number
ISO/FDIS 5211:2023(E)

© ISO 2023

iTeh STANDARD PREVIEW
(standards.iteh.ai)

ISO/FDIS 5211

<https://standards.iteh.ai/catalog/standards/sist/254f808c-e149-421e-af2b-a70d9d51c8fe/iso-fdis-5211>



COPYRIGHT PROTECTED DOCUMENT

© ISO 2023

All rights reserved. Unless otherwise specified, or required in the context of its implementation, no part of this publication may be reproduced or utilized otherwise in any form or by any means, electronic or mechanical, including photocopying, or posting on the internet or an intranet, without prior written permission. Permission can be requested from either ISO at the address below or ISO's member body in the country of the requester.

ISO copyright office
CP 401 • Ch. de Blandonnet 8
CH-1214 Vernier, Geneva
Phone: +41 22 749 01 11
Email: copyright@iso.org
Website: www.iso.org

Published in Switzerland

Contents

	Page
Foreword.....	iv
Introduction.....	v
1 Scope.....	1
2 Normative references.....	1
3 Terms and definitions.....	1
4 Maximum flange torques.....	2
5 Flange dimensions.....	3
6 Designation.....	5
7 Dimensions and torques.....	6
7.1 General.....	6
7.2 Drive by key(s).....	6
7.3 Drive by parallel or diagonal square head.....	9
7.4 Drive by flat head.....	10
7.5 Drive by improved flat head.....	12
7.6 Drive by involute spline.....	13
7.7 Drive by bi-square.....	14
8 Position of driven components at interface below part-turn actuator.....	15
8.1 Drive by key(s).....	15
8.2 Drive by parallel or diagonal square head or bi-square.....	17
8.3 Drive by flat head.....	18
9 Dowel pins.....	18
Annex A (informative) Explanation of calculations.....	20
Annex B (normative) Dimensions of keys and keyways.....	22
Bibliography.....	28

Foreword

ISO (the International Organization for Standardization) is a worldwide federation of national standards bodies (ISO member bodies). The work of preparing International Standards is normally carried out through ISO technical committees. Each member body interested in a subject for which a technical committee has been established has the right to be represented on that committee. International organizations, governmental and non-governmental, in liaison with ISO, also take part in the work. ISO collaborates closely with the International Electrotechnical Commission (IEC) on all matters of electrotechnical standardization.

The procedures used to develop this document and those intended for its further maintenance are described in the ISO/IEC Directives, Part 1. In particular, the different approval criteria needed for the different types of ISO documents should be noted. This document was drafted in accordance with the editorial rules of the ISO/IEC Directives, Part 2 (see www.iso.org/directives).

ISO draws attention to the possibility that the implementation of this document may involve the use of (a) patent(s). ISO takes no position concerning the evidence, validity or applicability of any claimed patent rights in respect thereof. As of the date of publication of this document, ISO had not received notice of (a) patent(s) which may be required to implement this document. However, implementers are cautioned that this may not represent the latest information, which may be obtained from the patent database available at www.iso.org/patents. ISO shall not be held responsible for identifying any or all such patent rights.

Any trade name used in this document is information given for the convenience of users and does not constitute an endorsement.

For an explanation of the voluntary nature of standards, the meaning of ISO specific terms and expressions related to conformity assessment, as well as information about ISO's adherence to the World Trade Organization (WTO) principles in the Technical Barriers to Trade (TBT), see www.iso.org/iso/foreword.html.

This document was prepared by Technical Committee ISO/TC 153, *Valves*, in collaboration with the European Committee for Standardization (CEN) Technical Committee CEN/TC 69, *Industrial valves*, in accordance with the Agreement on technical cooperation between ISO and CEN (Vienna Agreement).

This third edition cancels and replaces the second edition (ISO 5211:2017), which has been technically revised.

The main changes are as follows:

- dimensions and tolerances for keys and keyways were added in a new [Annex B](#);
- a reference to the new [Annex B](#) was added in [7.2](#);
- editorial changes were made.

Any feedback or questions on this document should be directed to the user's national standards body. A complete listing of these bodies can be found at www.iso.org/members.html.

Introduction

The purpose of this document is to establish certain basic requirements for the attachment of part-turn actuators, in order to define the interface between actuator and valve.

This document is, in general, considered in conjunction with the specific requirements which may be agreed between the parties concerned.

NOTE 1 In this document, the term “valve” can also be understood to include “valve with an intermediate support” [see [Figure 1 b](#)].

NOTE 2 When a combination of a multi-turn actuator and separate part-turn gearbox is coupled to form a part-turn actuator, the multi-turn attachment to the gearbox is in accordance with ISO 5210:2023, Figures 1 c) and 1 d). A combination of a multi-turn actuator with integral part-turn gearbox supplied as a part-turn actuator is in accordance with [Figures 1a](#)) and [1b](#)).

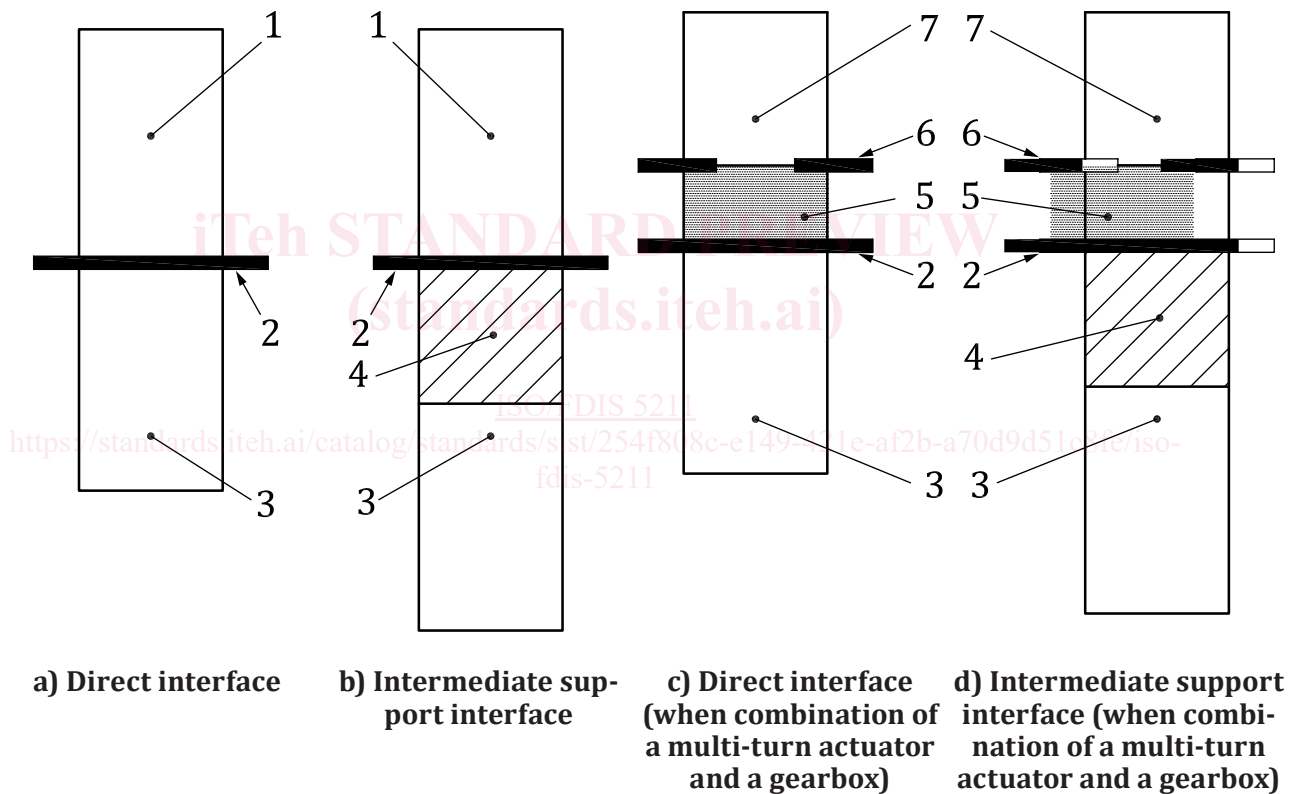

Key

- | | | | |
|---|-------------------------------|---|--------------------------|
| 1 | part-turn actuator | 5 | gearbox |
| 2 | interface (see this document) | 6 | interface (see ISO 5210) |
| 3 | valve | 7 | multi-turn actuator |
| 4 | intermediate support | | |

Figure 1 — Interface between part-turn actuator and valve

Industrial valves — Part-turn actuator attachments

1 Scope

This document specifies requirements for the attachment of part-turn actuators, with or without gearboxes, to industrial valves.

The attachment of part-turn actuators to control valves in accordance with the requirements of this document is subject to an agreement between the supplier and the purchaser.

This document specifies:

- flange dimensions necessary for the attachment of part-turn actuators to industrial valves [see [Figures 1 a\)](#) and [1 c\)](#)] or to intermediate supports [see [Figures 1 b\)](#) and [1 d\)](#)];
- driving component dimensions of part-turn actuators necessary to attach them to the driven components;
- reference values for torques for interfaces and for couplings having the dimensions specified in this document.

The attachment of the intermediate support to the valve is out of the scope of this document.

2 Normative references

The following documents are referred to in the text in such a way that some or all of their content constitutes requirements of this document. For dated references, only the edition cited applies. For undated references, the latest edition of the referenced document (including any amendments) applies.

ISO 273, *Fasteners — Clearance holes for bolts and screws*

ISO 4156-1, *Straight cylindrical involute splines — Metric module, side fit — Part 1: Generalities*

3 Terms and definitions

For the purposes of this document, the following terms and definitions apply.

ISO and IEC maintain terminology databases for use in standardization at the following addresses:

- ISO Online browsing platform: available at <https://www.iso.org/obp>
- IEC Electropedia: available at <https://www.electropedia.org/>

3.1 actuator

any device designed for attachment to a general-purpose industrial valve in order to provide for the operation of the valve

Note 1 to entry: The device is designed to operate using motive energy which may be electrical, pneumatic, hydraulic, manual, etc., or a combination of these. Movement is limited by travel, *torque* ([3.5](#)) and/or thrust.

**3.2
multi-turn actuator**

actuator (3.1) which transmits *torque* (3.5) to the valve for at least one revolution and may be capable of withstanding thrust

Note 1 to entry: An actuator may be a combination of a multi-turn actuator and multi-turn *gearbox* (3.4).

**3.3
part-turn actuator**

actuator (3.1) which transmits *torque* (3.5) to the valve for a rotation of one revolution or less and does not have to withstand axial thrust

Note 1 to entry: A part-turn actuator may be a combination of a *multi-turn actuator* (3.2) and part-turn *gearbox* (3.4).

**3.4
gearbox**

any mechanism designed to reduce the *torque* (3.5) required to operate a valve

**3.5
torque**

turning moment transmitted through the mounting flanges and connection components

Note 1 to entry: Torque is expressed in newton-metres.

4 Maximum flange torques

The flange torque shall comply with the values listed in [Table 1](#) which represent the maximum torques which can be transmitted through the mounting flange.

Table 1 — Maximum flange torque values

Flange type	Maximum flange torque [Nm]
F03	32
F04	63
F05	125
F07	250
F10	500
F12	1 000
F14	2 000
F16	4 000
F25	8 000
F30	16 000
F35	32 000
F40	63 000
F48	125 000
F60	250 000
F80	500 000
F100	1 000 000

The values specified in [Table 1](#) have been defined on the basis of bolts in tension only at a stress of 290 MPa and a coefficient of friction of 0,2 between the mounting interface. All variations in these defined parameters lead to variations of the transmittable torque values. See [Annex A](#) for more details on the calculation method.

The selection of flange types for a particular application should take into account the additional torques that may be generated because of inertia or other factors.

5 Flange dimensions

Flanges for part-turn actuator attachments shall comply with the dimensions shown in [Figure 2](#) and given in [Table 2](#). The method of attachment shall be by means of studs, screws or through bolting. When through bolting is used, the diameter of the clearance holes shall permit the use of bolts of a size given by the corresponding dimension d_4 in [Table 2](#).

Holes for the studs, screws or bolts shall be equi-spaced and positioned off-centre (see [Figure 3](#) and [Table 3](#)) and shall conform to the requirements of ISO 273.

The flange on the valve shall have a recess corresponding to the diameter d_2 . A spigot on the part-turn actuator is optional.

The minimum values for dimension h_2 shown in [Table 2](#) apply to flanges having material of proof stress $R_e \geq 200$ MPa. The minimum values for dimension h_2 applied to flanges having materials of proof stress $R_e \leq 200$ MPa shall be agreed between manufacturer and purchaser. The minimum values for dimension h_3 shall be at least $1 \times d_4$.

Dimension d_1 has been based on providing sufficient landing for the nuts and bolt heads where applicable. Such landing is defined as a radius from the bolt hole centre with the dimension $(d_1 - d_3) / 2$, and is a minimum. The flange shape of both valve and actuator outside these areas of landing is left to the option of the manufacturer.

The dimensions and bolting material are based on bolts in tension at a maximum stress of 290 MPa. On agreement, between the manufacturer/supplier and purchaser, bolting material with different tensile strength can be used, with no dimensional changes but with potential variation of the transmittable torque.

ISO/FDIS 5211

Above flange type F60 alternative dimensions and/or torque ratings may be used on agreement between manufacturer/supplier and purchaser.

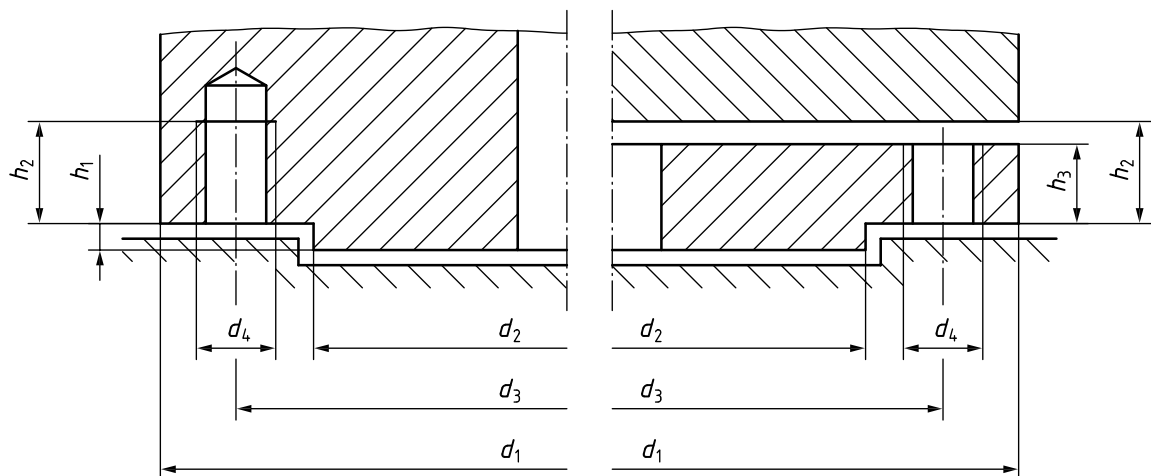

Figure 2 — Flange dimensions

Table 2 — Flange dimensions

Dimensions in millimetres

Flange type	Dimensions							Number of screws, studs or bolts <i>n</i>
	d_1 min.	d_2^a	d_3	d_4	h_1 max.	h_2 min.	h_3 min.	
F03	Ø46	Ø25	Ø36	M5	3	8	5	4
F04	Ø54	Ø30	Ø42	M5	3	8	5	4
F05	Ø65	Ø35	Ø50	M6	3	9	6	4
F07	Ø90	Ø55	Ø70	M8	3	12	8	4
F10	Ø125	Ø70	Ø102	M10	3	15	10	4
F12	Ø150	Ø85	Ø125	M12	3	18	12	4
F14	Ø175	Ø100	Ø140	M16	4	24	16	4
F16	Ø210	Ø130	Ø165	M20	5	30	20	4
F25	Ø300	Ø200	Ø254	M16	5	24	16	8
F30	Ø350	Ø230	Ø298	M20	5	30	20	8
F35	Ø415	Ø260	Ø356	M30	5	45	30	8
F40	Ø475	Ø300	Ø406	M36	8	54	36	8
F48	Ø560	Ø370	Ø483	M36	8	54	36	12
F60	Ø686	Ø470	Ø603	M36	8	54	36	20
F80	Ø900	Ø670	Ø813	M42	10	63	42	20
F100	Ø1 200	Ø870	Ø1 042	M42	10	63	42	32

^a d_2 shall be manufactured within the diameter tolerance f8.

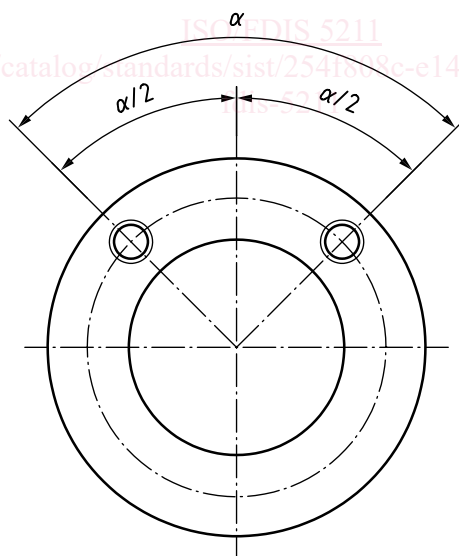

Figure 3 — Position of holes

Table 3 — Position of holes

Flange type	$\alpha/2$
F03 to F16	45°
F25 to F40	22,5°
F48	15°
F60 to F80	9°

Table 3 (continued)

Flange type	$\alpha/2$
F100	5,625°

6 Designation

Part-turn valve actuator attachments shall be designated as follows:

- flange designation:
 - flange type as per [Table 1](#);
 - a capital letter for spigot identification:
 - Y with spigot;
 - N without spigot;
- drive designation:
 - an additional capital letter for drive identification:
 - V for single-key drive;
 - W for 90° two-key drive;
 - X for 180° two-key drive;
 - L for parallel square drive;
 - D for diagonal square drive;
 - H for flat head drive;
 - G for improved flat head drive;
 - S for involute spline;
 - T for bi-square;
 - the actual dimensions of the drive (in millimetres):
 - dimension d_7 for key drives (see [Figure 4](#) and [Table 4](#));
 - dimension s for square or flat drives (see [Figures 5](#) or [6](#) and [Table 5](#) or [Figure 7](#) and [Table 6](#));
 - module m for involute spline (see [Figure 9](#) and [Table 8](#)).

EXAMPLE

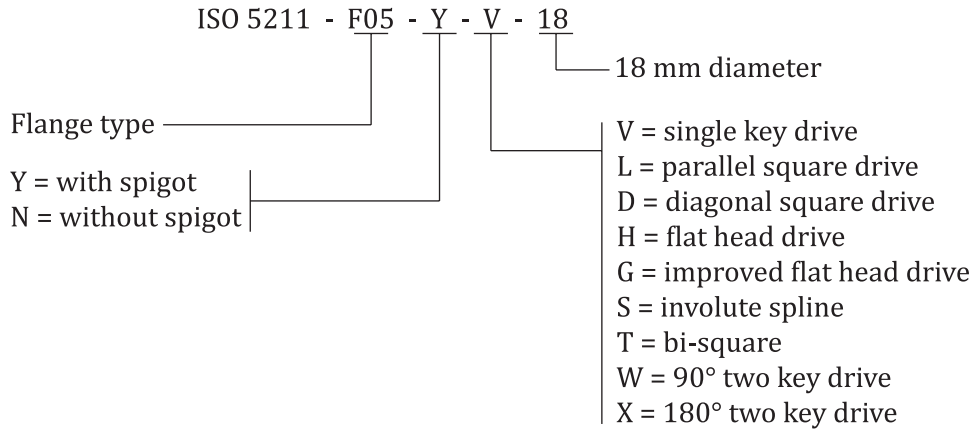

ISO 5211 – F05 Y – V – 18, identifies a part-turn valve actuator attachment in accordance with this document, with F05 flange type, spigot and single-key drive with 18 mm diameter.

NOTE The designation is not a marking requirement.

7 Dimensions and torques

7.1 General

To ensure that no interference can occur between the driving component and the driven component, the length of the driven component above the interface shall be limited so that there is a clearance between both parts.

The depth of engagement of the valve driven component into the actuator drive component and the surface area of contact between the faces of the actuator drive component and the faces of the valve driven component should be considered to ensure that the stresses caused by contact do not exceed the capability of the component materials. In some cases, it may be necessary to use materials with superior mechanical properties and/or to reduce the output torque of the actuator.

7.2 Drive by key(s)

Dimensions of the drive components for key drive shall meet the requirements of [Figure 4](#) and [Table 4](#).

The values of d_7 , h_4 and l_5 in [Table 4](#) are based on single-key design up to 98 mm shaft diameter.

Where more than one key is required to transmit the torque, the dimensions in [Table 4](#) shall still apply.

The key dimensions shall conform with those given in [Annex B](#).

The keyway(s) in the driving component shall correspond to the position of the key(s) supplied on the driven component as specified in [8.1](#), [Figures 11](#), [12](#) or [13](#).

The key(s) shall be secured in position by suitable means.