



Designation: D807 – 14

Standard Practice for Assessing the Tendency of Industrial Boiler Waters to Cause Embrittlement (USBM¹ Embrittlement Detector Method)²

This standard is issued under the fixed designation D807; the number immediately following the designation indicates the year of original adoption or, in the case of revision, the year of last revision. A number in parentheses indicates the year of last reapproval. A superscript epsilon (ϵ) indicates an editorial change since the last revision or reapproval.

1. Scope

1.1 This practice,³ known as the embrittlement-detector method, covers the apparatus and procedure for determining the embrittling or nonembrittling characteristics of the water in an operating boiler. The interpretation of the results shall be restricted to the limits set forth in 8.6.

NOTE 1—The embrittlement detector was designed to reproduce closely the conditions existing in an actual boiler seam. It is considered probable that the individual conditions of leakage, concentration, and stress in the boiler seam can equal those in the detector. The essential difference between the detector and the boiler is that the former is so constructed and operated that these three major factors act simultaneously, continuously, and under the most favorable circumstances to produce cracking; whereas, in the boiler the three factors are brought together only under unique circumstances. Furthermore, in the detector any cracking is produced in a small test surface that can be inspected thoroughly, while the susceptible areas in a boiler are large and can be inspected only with difficulty. In these respects the embrittlement detector provides an accelerated test of the fourth condition necessary for embrittlement, the embrittling nature of the boiler water.

NOTE 2—Cracks in a specimen after being subjected to this test indicate that the boiler water can cause embrittlement cracking, but not that the boiler in question necessarily has cracked or will crack.

1.2 The effectiveness of treatment to prevent cracking, as well as an indication of whether an unsafe condition exists, are shown by this practice. Such treatments are evaluated in terms of method specimen resistance to failure.

1.3 The practice may be applied to embrittlement resistance testing of steels other than boiler plate, provided that a

duplicate, unexposed specimen does not crack when bent 90° on a 2-in. (51-mm) radius.

1.4 The values stated in inch-pound units are to be regarded as standard. The values given in parentheses are mathematical conversions to SI units that are provided for information only and are not considered standard.

1.5 *This standard does not purport to address all of the safety concerns, if any, associated with its use. It is the responsibility of the user of this standard to establish appropriate safety, health, and environmental practices and determine the applicability of regulatory limitations prior to use.*

1.6 *This international standard was developed in accordance with internationally recognized principles on standardization established in the Decision on Principles for the Development of International Standards, Guides and Recommendations issued by the World Trade Organization Technical Barriers to Trade (TBT) Committee.*

2. Referenced Documents

- 2.1 *ASTM Standards*:⁵
- A108 Specification for Steel Bar, Carbon and Alloy, Cold-Finished
 - A515/A515M Specification for Pressure Vessel Plates, Carbon Steel, for Intermediate- and Higher-Temperature Service
 - D1129 Terminology Relating to Water
 - D1193 Specification for Reagent Water
 - E3 Guide for Preparation of Metallographic Specimens
 - E883 Guide for Reflected-Light Photomicrography
 - E1351 Practice for Production and Evaluation of Field Metallographic Replicas

3. Terminology

3.1 *Definitions*—For definitions of other terms used in this practice, refer to Terminology D1129.

⁵ For referenced ASTM standards, visit the ASTM website, www.astm.org, or contact ASTM Customer Service at service@astm.org. For *Annual Book of ASTM Standards* volume information, refer to the standard's Document Summary page on the ASTM website.

¹ United States Bureau of Mines.

² This test method is under the jurisdiction of ASTM Committee D19 on Water and is the direct responsibility of Subcommittee D19.03 on Sampling Water and Water-Formed Deposits, Analysis of Water for Power Generation and Process Use, On-Line Water Analysis, and Surveillance of Water.

Current edition approved Jan. 1, 2014. Published January 2014. Originally approved in 1944. Last previous edition approved in 2009 as D807 – 05 (2009). DOI: 10.1520/D0807-14.

³ This test method was developed during an investigation conducted under a cooperative agreement between the Joint Research Committee on Boiler Feedwater Studies and the United States Bureau of Mines. For information on the development of this test method reference may be made to the following: Schroeder and Berk, 1941 (1);⁴ Schroeder, Berk, and Stoddard, 1941 (2); *Transactions of the American Society of Mechanical Engineers*, 1942 (3); Whirl and Purcell, 1942 (4); and Berk and Schroeder, 1943 (5).

3.2 Definitions of Terms Specific to This Standard:

3.2.1 embrittlement cracking, *n*—a form of metal failure that occurs in steam boilers at riveted joints and at tube ends, the cracking being predominantly intercrystalline.

3.2.1.1 Discussion—This form of cracking, which has been known as “caustic embrittlement,” is believed to result from the action of certain constituents of concentrated boiler water upon steel under stress. For a detailed discussion as to what cracking should be considered significant for the purpose of this practice, see 8.6.

4. Summary of Practice

4.1 For embrittlement cracking of the boiler metal to be possible, the boiler water must concentrate a thousand times or more in contact with the metal under high residual or applied tensile stress. In a boiler such concentration may take place in riveted seams or in annular spaces at tube ends, and the steel at such locations may be highly stressed when the boiler is constructed or may become highly stressed when it is operated. If the chemicals in the boiler water concentrate in the seams to develop an embrittling solution, cracking may occur.

4.2 In the embrittlement detector (Fig. 1), the conditions of concentration and stress are provided by the design of the unit. Boiler water is permitted to seep slowly from the small hole through the restricted space between the contact surfaces of the test specimen and the groove in the block. As this extremely slow flow takes place toward atmospheric pressure, the heat in the metal and in the liquid causes progressive evaporation to produce an increasingly concentrated solution. When the detector is properly adjusted, concentrated boiler water is in contact with the stressed test surface of the specimen, thus providing the necessary factor to determine whether the boiler water can cause embrittlement cracking.

5. Significance and Use

5.1 Embrittlement is a form of intercrystalline cracking that is associated with the exposure of boiler steel to a combination of physical and chemical factors. For embrittlement of boiler metal to occur, the metal must be under stress, it must be at the site of a leak, and it must be exposed to the concentrated boiler water. In addition, the boiler water must be embrittling in nature. The precise chemical causes of the embrittling nature of some waters are not well understood. Experience has shown that certain waters exhibit an embrittling characteristic while others do not.

5.2 Because embrittlement is a form of cracking, it is nearly impossible to detect in an operating boiler until a failure has occurred. In general, cracking failures tend to be sudden, and often with serious consequences. This practice offers a way to determine whether a particular water is embrittling or not. It also makes it possible to determine if specific treatment actions have rendered the water nonembrittling.

6. Apparatus

6.1 Embrittlement Detector—The embrittlement detector shall consist of the unit, complete with steel specimen, as shown assembled in cross section in Fig. 1 and as the installed unit in Fig. 2. The principal parts consist of a rectangular block base through which the water circulates and in which a groove has been machined to receive the test specimen, a test specimen, and a clamping plate which fits over four stud bolts in the block. When the nuts on the stud bolts are tightened, the pressure of the clamping plate molds the test specimen to the contour of the groove, thus stressing in tension the surface of the specimen. Working drawings showing the dimensions of all the machined parts are shown in Figs. 3-5. Accurate machining of the groove with respect to the small hole through which the boiler water is brought to the test surface of the specimen is especially important.

6.2 Wrenches—An extra-heavy box-type wrench of 1 1/16-in. (27-mm) opening is recommended for assembling and adjusting the unit. A lighter box-type wrench of 3/4-in. (19-mm)

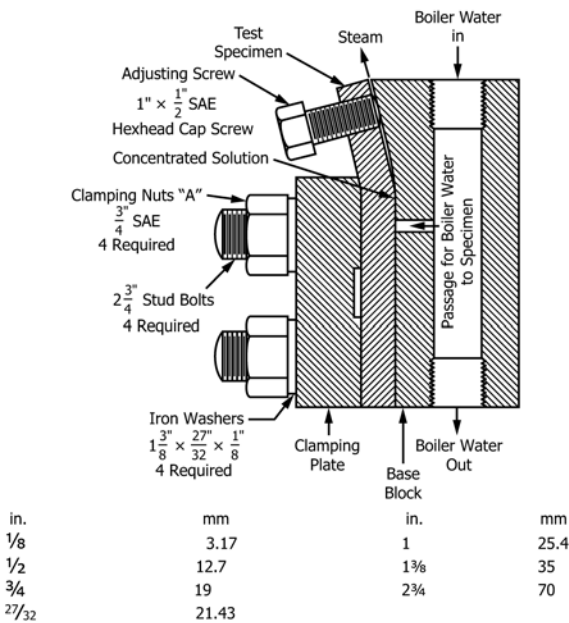

FIG. 1 Cross-Section of Embrittlement Detector

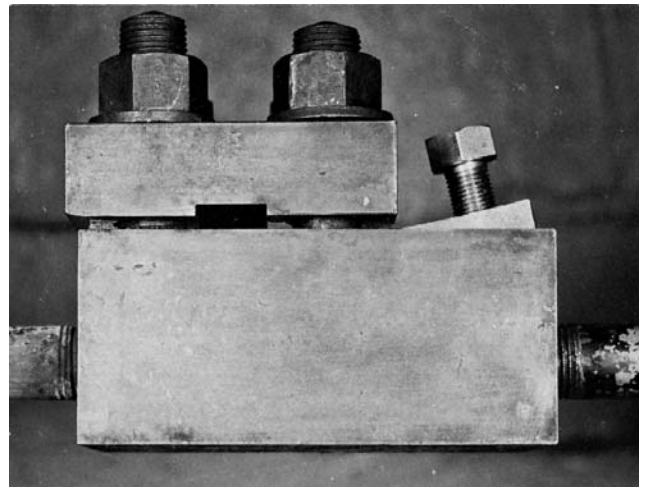
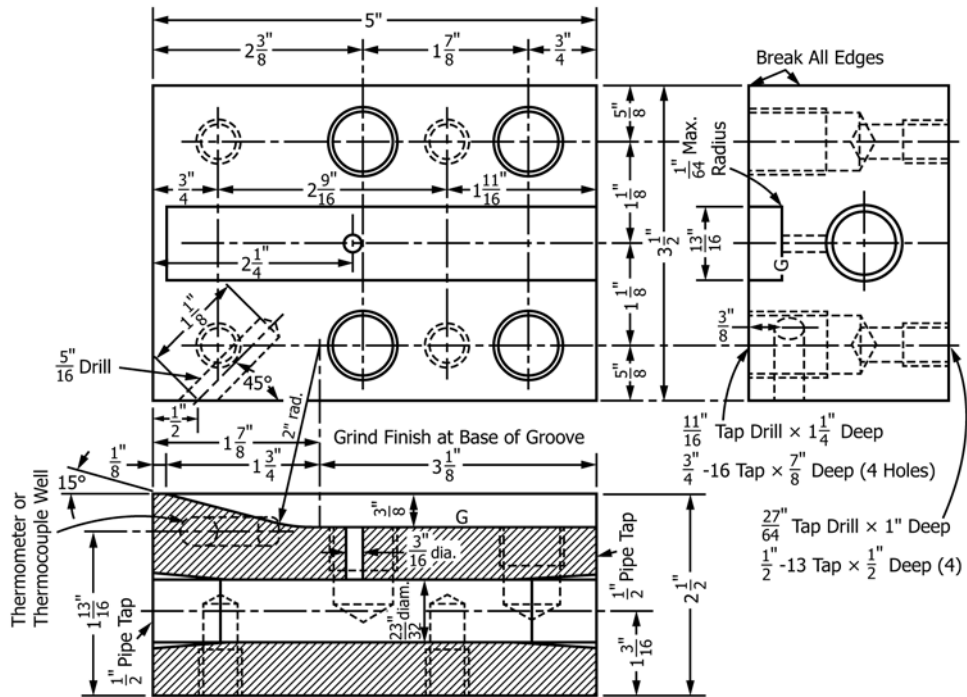
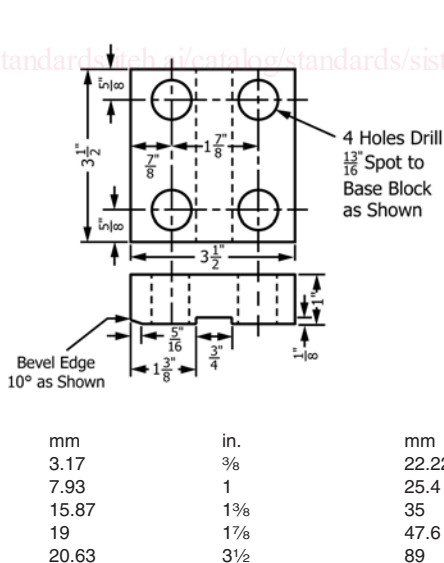

FIG. 2 Embrittlement Detector Installed



in.	mm	in.	mm	in.	mm	in.	mm
1/64	0.39	1 1/16	17.46	1 3/16	30	2 1/4	57
1/8	3.17	2 3/32	18.25	1 1/4	31.7	2 3/8	60
3/16	4.76	3/4	19	1 1/16	42.8	2 1/2	63.5
5/16	7.93	1 3/16	20.63	1 3/4	44.4	2 9/16	65
3/8	9.52	7/8	22.22	1 13/16	46	3 1/8	79
27/64	10.71	1	25.4	1 7/8	47.6	3 1/2	89
1/2	12.7	1 1/8	28.6	2	50.8	5	127
5/8	15.87						

FIG. 3 Dimensional Details of Base Block of Embrittlement Detector



in.	mm	in.	mm
1/8	3.17	3/8	22.22
5/16	7.93	1	25.4
5/8	15.87	1 3/8	35
3/4	19	1 7/8	47.6
13/16	20.63	3 1/2	89

FIG. 4 Dimensional Details of Clamping Plate of Embrittlement Detector

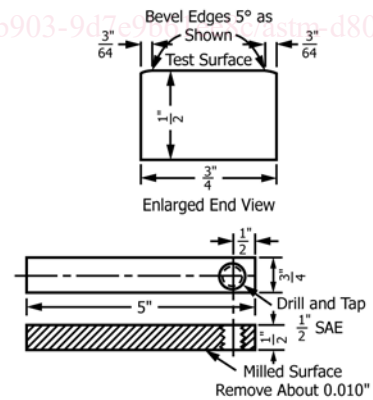

in.	mm	in.	mm
0.010	0.25	3/4	19
3/64	1.19	5	127
1/2	12.7		

FIG. 5 Dimensional Details of Test Specimen

opening is recommended for the hexagonal head of the adjusting screw in the end of the specimen.

6.3 Jig for Bending Specimen—A jig as shown in Fig. 6, or its equivalent, is recommended for bending the specimen with a hydraulic press at the end of the test to reveal cracks that may have been formed but are too fine to be visible without