



Designation: D7226 – 13

## Standard Test Method for Determining the Viscosity of Emulsified Asphalts Using a Rotational Paddle Viscometer<sup>1</sup>

This standard is issued under the fixed designation D7226; the number immediately following the designation indicates the year of original adoption or, in the case of revision, the year of last revision. A number in parentheses indicates the year of last reapproval. A superscript epsilon ( $\epsilon$ ) indicates an editorial change since the last revision or reapproval.

### 1. Scope

1.1 This test method utilizes the rotational paddle viscometer to measure the viscosity of emulsified asphalt. It is applicable to all the emulsified asphalts described in Specifications **D977** and **D2397**.

1.2 The values stated in SI units are to be regarded as standard. No other units of measurement are included in this standard.

1.3 *This standard does not purport to address all of the safety concerns, if any, associated with its use. It is the responsibility of the user of this standard to establish appropriate safety and health practices and determine the applicability of regulatory limitations prior to use.*

### 2. Referenced Documents

2.1 *ASTM Standards:*<sup>2</sup>

**D140** Practice for Sampling Bituminous Materials

**D977** Specification for Emulsified Asphalt

**D2397** Specification for Cationic Emulsified Asphalt

**E11** Specification for Woven Wire Test Sieve Cloth and Test Sieves

### 3. Terminology

3.1 *Definitions:*

3.1.1 *viscosity, n*—ratio of shear stress to shear rate.

3.1.1.1 *Discussion*—The SI unit of viscosity is the Pascal second (Pa·s).<sup>3</sup>

### 4. Summary of Test Method

4.1 The rotational paddle viscometer method is used to measure the apparent viscosity of emulsified asphalt at 50°C,

25°C, or other agreed-upon temperatures. A microprocessor circuitry system functioning in tandem with a temperature probe and equipped with internal electronic sensors detects and analyzes the preset temperature. A paddle is immersed in the emulsified asphalt sample and is rotated at 100 RPM. The apparent viscosity of the sample is obtained and read from the electronic display or an optional printer.

### 5. Significance and Use

5.1 The viscosity of emulsified asphalts characterizes their flow properties and affects their utility at 50°C or at other temperatures. The sprayability and workability of an emulsified asphalt are directly related to its viscosity for many applications. The material must be thin enough to be sprayed yet thick enough such that it will not flow from the crown or grade of the road. For mixing grade emulsified asphalts the viscosity will affect its workability and resulting film thickness on the aggregate. This test method is useful to measure the apparent viscosity of emulsified asphalt at a temperature of 50°C, 25°C, or another agreed-upon temperature. The preset temperature and rotational speed at 100 RPM allow for an automated and consistent determination of an emulsified asphalt viscosity within a short time.

### 6. Apparatus

6.1 The rotational paddle viscometer test system consists of a paddle, temperature probe, sample cup, the sample cup cover, a means of controlling the sample temperature to within  $\pm 0.1^\circ\text{C}$  and a readout system to display viscosity. The dimensions of the sample cup and paddle are shown in **Figs. 1-3**.

6.2 *Thermometer*—Any thermometric device can be used to monitor the temperature of the sample being conditioned for testing.

6.3 *Sieve*—An 850- $\mu\text{m}$  sieve or a 20-mesh strainer of wire cloth, framed or unframed, conforming to Specification **E11** is used.

6.4 *Oven/Water Bath*—An oven/water bath capable of maintaining the required testing temperature within the limit of  $\pm 3^\circ\text{C}$ .

<sup>1</sup> This test method is under the jurisdiction of ASTM Committee **D04** on Road and Paving Materials and is the direct responsibility of Subcommittee **D04.42** on Emulsified Asphalt Test.

Current edition approved Dec. 1, 2013. Published January 2014. Originally approved in 2006. Last previous edition approved in 2011 as D7226 – 11. DOI: 10.1520/D7226-13.

<sup>2</sup> For referenced ASTM standards, visit the ASTM website, www.astm.org, or contact ASTM Customer Service at service@astm.org. For *Annual Book of ASTM Standards* volume information, refer to the standard's Document Summary page on the ASTM website.

<sup>3</sup> The centimetre gram second (cgs) unit of viscosity is the poise (dynes/cm<sup>2</sup>) and is equivalent to 0.1 Pa·s. One centipoise (cP) is one millipascal second (mPa·s).

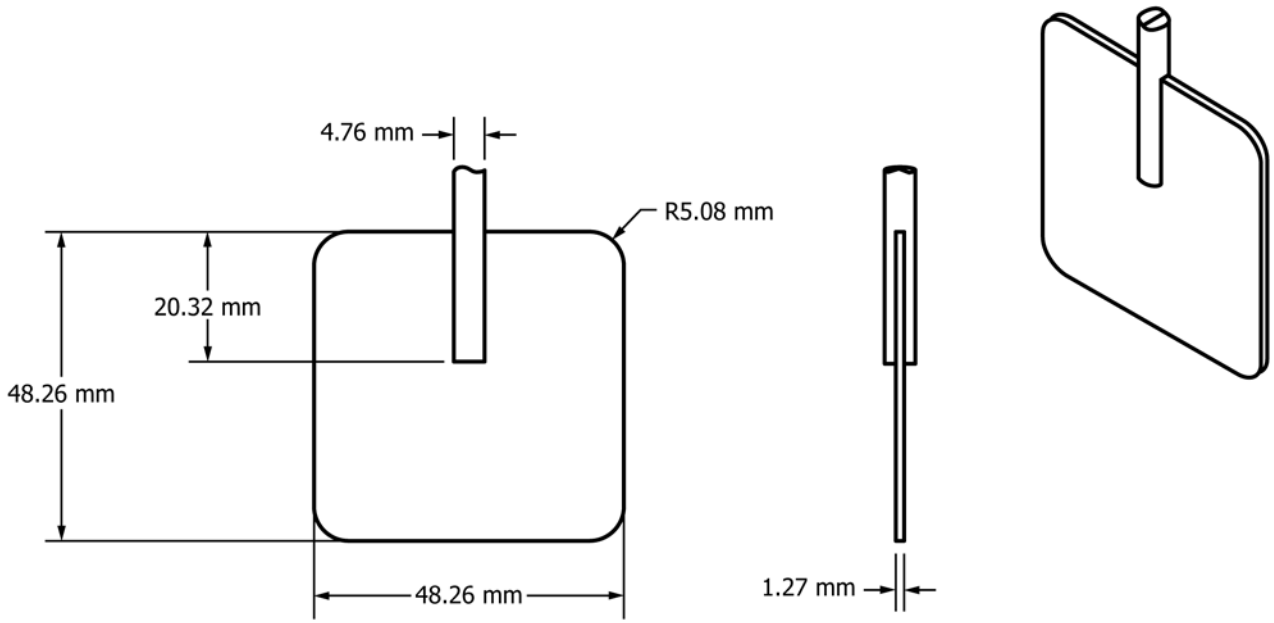

Tolerance  $\pm .127$  mm

FIG. 1 Paddle Dimensions

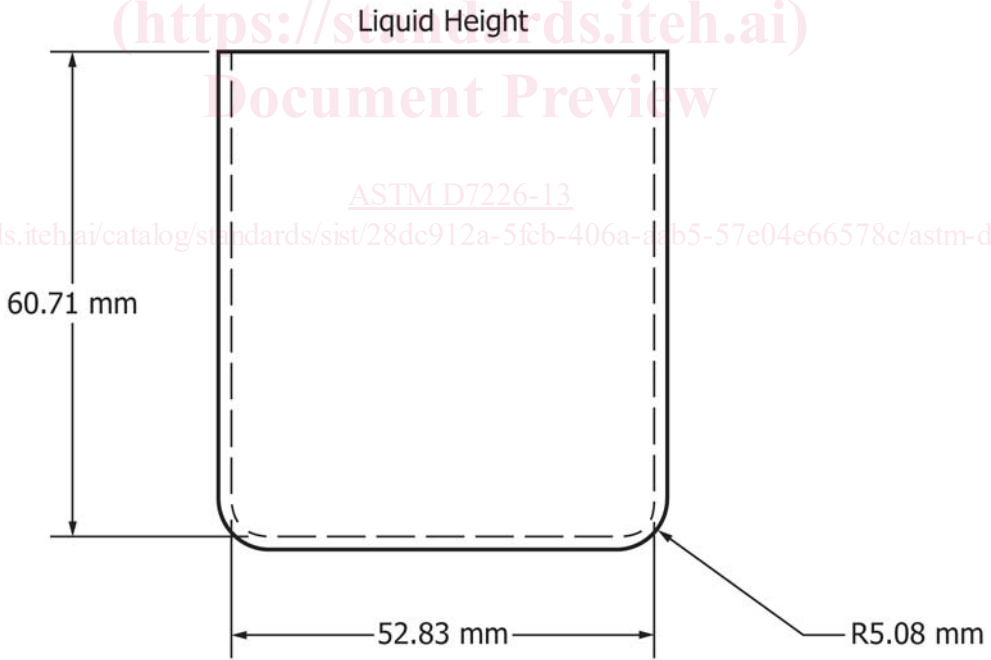

Tolerance  $\pm .127$  mm

FIG. 2 Sample Cup Dimensions