



Designation: **E2001—08 E2001 – 13**

Standard Guide for Resonant Ultrasound Spectroscopy for Defect Detection in Both Metallic and Non-metallic Parts¹

This standard is issued under the fixed designation E2001; the number immediately following the designation indicates the year of original adoption or, in the case of revision, the year of last revision. A number in parentheses indicates the year of last reapproval. A superscript epsilon (ϵ) indicates an editorial change since the last revision or reapproval.

1. Scope—Scope*

1.1 This guide describes a procedure for detecting defects in metallic and non-metallic parts using the resonant ultrasound spectroscopy method. The procedure is intended for use with instruments capable of exciting and recording whole body resonant states within parts which exhibit acoustical or ultrasonic ringing. It is used to distinguish acceptable parts from those containing defects, such as cracks, voids, chips, density defects, tempering changes, and dimensional variations that are closely correlated with the parts' mechanical system dynamic response.

1.2 The values stated in SI units are to be regarded as standard. No other units of measurement are included in this standard.

1.3 *This standard does not purport to address all of the safety concerns, if any, associated with its use. It is the responsibility of the user of this standard to establish appropriate safety and health practices and determine the applicability of regulatory limitations prior to use.*

2. Referenced Documents

2.1 *ASTM Standards:*²

[E1316 Terminology for Nondestructive Examinations](#)

[E1876 Test Method for Dynamic Young's Modulus, Shear Modulus, and Poisson's Ratio by Impulse Excitation of Vibration](#)

[E2534 Practice for Process Compensated Resonance Testing Via Swept Sine Input for Metallic and Non-Metallic Parts](#)

3. Terminology

3.1 *Definitions*—The definitions of terms relating to conventional ultrasonics can be found in Terminology [E1316](#).

3.2 *Definitions of Terms Specific to This Standard:*

3.2.1 *resonant ultrasonic spectroscopy (RUS), n*—a nondestructive examination method, which employs resonant ultrasound methodology for the detection and assessment of variations and mechanical properties of a test object. In this procedure, whereby a rigid part is caused to resonate, the resonances are compared to a previously defined resonance pattern. Based on this comparison the part is judged to be either acceptable or unacceptable.

3.2.2 *swept sine method, n*—the use of an excitation source to create a transient vibration in a test object over a range of frequencies. Specifically, the input frequency is swept over a range of frequencies and the output is characterized by a resonant amplitude response spectrum.

3.2.3 *impulse excitation method, n*—striking an object with a mechanical impact, or electromagnetic field (laser and/or EMAT) causing multiple resonances to be simultaneously stimulated.

3.2.4 *resonant inspection (RI), n*—any induced resonant nondestructive examination method employing an excitation force to create mechanical resonances for the purpose of identifying a test object's conformity to an established acceptable pattern.

4. Summary of the Technology (1)³

4.1 *Introduction:*

¹ This guide is under the jurisdiction of ASTM Committee [E07](#) on Nondestructive Testing and is the direct responsibility of Subcommittee [E07.06](#) on Ultrasonic Method. Current edition approved July 1, 2008 Dec. 1, 2013. Published July 2008 January 2014. Originally approved in 1998. Last previous edition approved in 2003 2008 as [E2001—98 E2001 - 08 \(2003\)](#). DOI: [10.1520/E2001-08-10.1520/E2001-13](#).

² For referenced ASTM standards, visit the ASTM website, [www.astm.org](#), or contact ASTM Customer Service at [service@astm.org](#). For *Annual Book of ASTM Standards* volume information, refer to the standard's Document Summary page on the ASTM website.

³ The boldface numbers in parentheses refer to the list of references at the end of this guide.

*A Summary of Changes section appears at the end of this standard

4.1.1 In addition to its basic research applications in physics, materials science, and geophysics, Resonant Ultrasound Spectroscopy (RUS) has been used successfully as an applied nondestructive testing tool. Resonant ultrasound spectroscopy in commercial, nondestructive testing has a few recognizable names including, RUS Nondestructive Testing, Acoustic Resonance Spectroscopy (ARS), and Resonant Inspection. Early references to this body of science often are termed the “swept sine method.” It was not until 1990 (2) that the name Resonant Ultrasound Spectroscopy appeared, but the two techniques are synonymous. Additionally, impulse methods, like the striking of a rail car wheel with a hammer, and listening for the responses, have been used for over 100 years to detect the existence of large cracks. RUS based techniques are becoming commonly used in the manufacture of steel, ceramic, and sintered metal parts. In these situations, a part is vibrated mechanically, and defects are detected based on changes in the pattern of resonances or variations from theoretically calculated or empirically acceptable spectra. RUS measures all resonances, in a defined range, of the part rather than scanning for individual defects. In a single measurement, RUS-based techniques potentially can test for numerous defects including cracks, chips, cold shuts, inclusions, voids, oxides, contaminants, missed processes or operations, and variations in dimension, hardness, porosity, nodularity, density, and heat treatment. Since the RUS measurement yields a whole body response, it is often difficult to discriminate between defect types. The technique is effective for detecting parts with structural anomalies, but less effective for diagnosing the exact location or cause of an anomaly within a part. Nevertheless, on certain types of parts, it can be accurate, fast, inexpensive and require no human judgment, making 100 % examination possible in selected circumstances. Many theoretical texts (3) discuss the relationship between resonances and elastic constants and include the specific application of RUS to the determination of elastic constants (4). The technology received a quantum increase in attention when Migliori published a review article, including the requisite inexpensive electronic designs and procedures from which materials properties could be measured quickly and accurately (5). The most recent applications include studies in ultrasonic attenuation, modulus determinations, thermodynamic properties, structural phase transitions, superconducting transitions, magnetic transitions, and the electronic properties of solids. A compendium of these applications may be found in the Migliori (1) text. Resonant ultrasound spectroscopy also found use in the study of the elastic properties of the Apollo moon rocks (6).

4.1.2 This guide is intended to provide a practical introduction to RUS-based nondestructive test (NDT), highlighting successful applications and outlining failures, limitations, and potential weaknesses. Vibrational resonances are considered from the perspective of defect detection in 4.2. In 4.3 and 4.4, a review of some of the types of RUS measurements are given and 4.6 examines the common practice of using the impulse excitation method. In 4.6, some example implementations and configurations of RUS systems and their applications are presented. Finally, the guide concludes with a discussion of constraints, which limit the effectiveness of RUS.

4.2 Mode Shapes and Defects:

4.2.1 Resonant ultrasound spectroscopy/NDT techniques, operate by driving a part at given frequencies and measuring its mechanical response (Fig. 1 contains a schematic one embodiment of a RUS apparatus). The process proceeds in small frequency steps over some previously determined region of interest. During such a sweep, the drive frequency typically brackets a resonance. When the excitation frequency is not matched to one of the part’s resonance frequencies, very little energy is coupled to the part; that is, there is little mechanical vibration. At resonance, however, the energy delivered to the part is coupled generating much larger mechanical vibrations. A part’s resonance frequencies are determined by the standard dynamic equations of motion, which include variables for mass, stiffness, and damping. From a materials perspective, this is affected by its dimensions (to include the shape and geometry) and by the density and the elastic constants of the material. The required frequency window for a scan depends on the size of the part, its mechanical rigidity, and the size of the defect being sought.

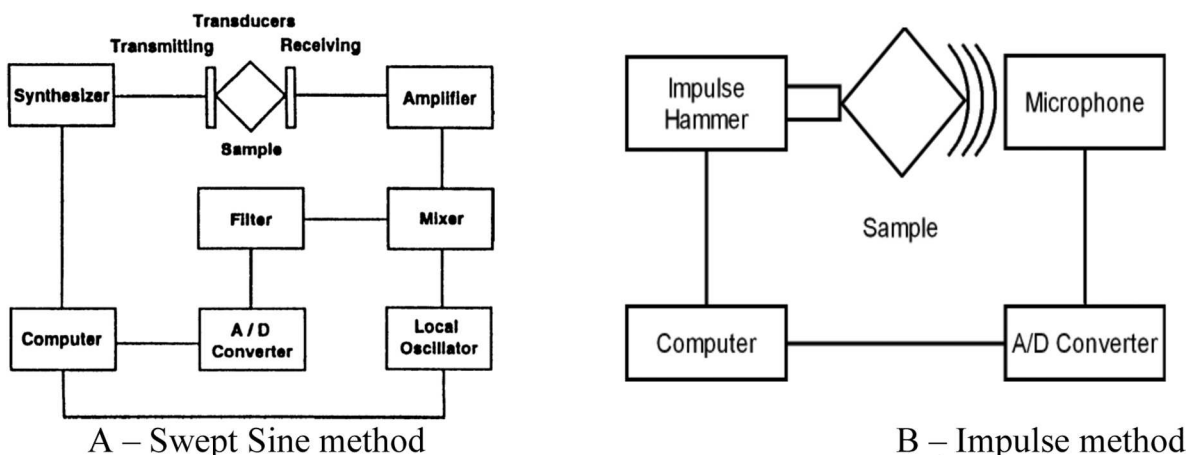

FIG. 1 Schematic of the Essential Electronic Building Blocks to Employ RUS in a Manufacturing Environment

4.2.2 Vibrational resonances produce a wide range of distortions. These distortions include shapes, which bend and twist. It is known that increasing the length of a cylinder will lower some resonant frequencies. Similarly, reducing the stiffness, that is, reducing the relevant elastic constant, lowers the associated resonant frequency for most modes; thus, for a given part, the resonant frequencies are measures of stiffness, and knowledge of the mode shape helps to determine what qualities of the part affect those frequencies. If a defect, such as a crack, is introduced into a region under strain, it will reduce the effective stiffness, that is, the part’s resistance to deformation, and will shift downward the frequency of resonant modes that introduce strain at the crack. This is one basis for detecting defects with RUS-based techniques.

4.2.3 The torsional modes represent a twisting of a cylinder about its axis. These resonances are easily identified because their frequencies remain constant for fixed length, independent of diameter. A crack will reduce the ability of the part to resist twisting, thereby reducing the effective stiffness, and thus, the frequency of a torsional mode. A large defect can be detected readily by its effect on the first few modes; however, smaller defects have much more subtle effects on stiffness, and therefore, require higher frequencies (high-order modes) to be detected. Detection of very small defects may require using the frequency corresponding to the fiftieth, or even higher, mode. Some modes do not produce strain in the end of the cylinder, therefore, they cannot detect end defects. To detect this type of defect, a more complex mode is required, the description of which is beyond the scope of this specification. A defect in the end will reduce the effective stiffness for this type of mode, and thus, will shift downward the frequency of the resonance. In general, it must be remembered that most modes will exhibit complex motions, and for highly symmetric objects, can be linear combinations of several degenerate modes, as discussed in 4.3.2.

4.3 General Approaches to RUS/NDT:

4.3.1 Test Evaluation Methods (1)—Once a fingerprint has been established, for conforming parts, numerous algorithms can be employed to either accept or reject the part. For example, if a frequency ± 50 Hz can be identified for all conforming parts, the detection of a peak outside of this boundary condition will cause the computer code to signal a “test reject” condition. The code, rather than the inspector, makes the accept/reject decision. The following sections will expand on some of these sorting criteria.

4.3.2 Frequency Shifts:

4.3.2.1 Resonant ultrasound spectroscopy measurements generally produce strains (even on resonance) that are well within the elastic limit of the materials under test, that is, the atomic displacements are small in keeping with the “nondestructive” aspect of the testing. If strains are applied above the elastic limit, a crack will tend to propagate, causing a mechanical failure. Note that certain important engineering properties, for example, the onset of plastic deformation, yield strength, etc., generally are not derivable from low-strain elastic properties. Sensitivity of the elastic properties of an object to the presence of a crack depends on the stiffness and geometry of the sample under test. This concept is expanded upon under 4.4.3.

4.3.2.2 Fig. 2 shows an example of the resonance spectrum for a conical ceramic part. Several specific types of modes are present in this scan, and their relative shifts could be used to detect defects as discussed above; however, the complexity is such that, for NDT purposes, some selections must be made so that only a portion of such a large amount of information is used. For

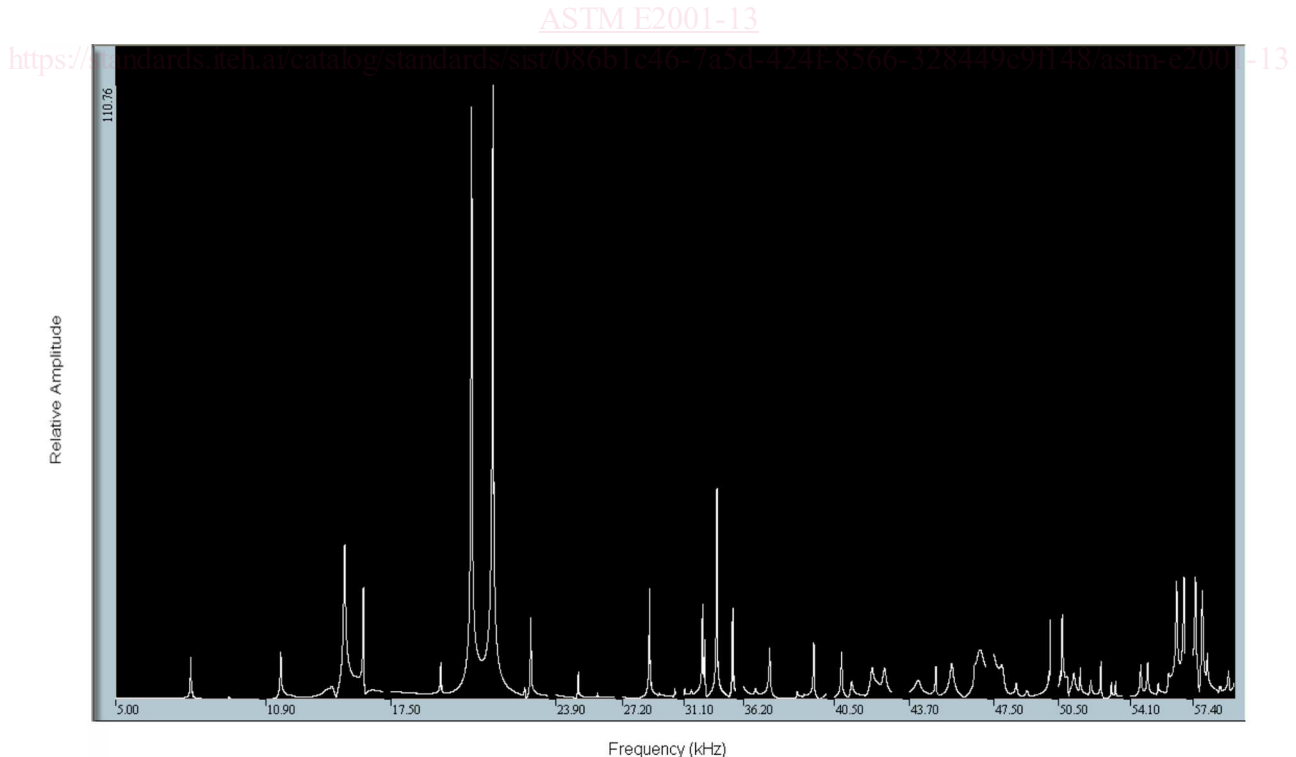

FIG. 2 Typical Broad-Spectrum Scan

simple part geometries, the mode type and frequency can be calculated, and selection of diagnostic modes can be based on these results. For complex geometries, empirical approaches have been developed to identify efficiently diagnostic modes for specific defects. In this process, a technician measures the spectra for a batch of known good and bad parts. The spectra are compared to identify diagnostic modes whose shift correlates with the presence of the defect. The key is to isolate a few resonances, which differ from one another, when known defects are present in the faulty parts.

4.3.3 *Peak Splitting*—One of the techniques employed for axially symmetric parts is identified in texts on basic wave physics (7). Some test procedures are based on simple frequency changes while others include the recognition that symmetry is broken when a defect is present in a homogeneous, isotropic symmetrical part. These techniques employ splitting of degeneracies or simply “splitting.” A cylinder actually has two degenerate bending modes, both orthogonal to its axis. The bending stiffness for both of these modes, and therefore their resonance frequency, is proportional to the diameter of the cylinder. Because the part is symmetric, both modes have the same stiffness, and therefore, the same frequency (the modes are said to be degenerate and appear to be a single resonance). When the symmetry is broken by a chip, however, the effective diameter is reduced for one of the orthogonal modes. This increases the frequency for that mode, so both modes are seen. In addition, a crack or inclusion affects the symmetry. This splitting of the resonances is illustrated in Fig. 3, which shows spectra for a good part and two defective parts. The part is a steel cylinder. Fig. 3 also demonstrates a useful feature of this particular technique, that is, the size of the splitting is proportional to the size of the defect. It is important to recognize that not all resonance peaks are degenerate. Pure torsional modes, for example, are not degenerate, so they cannot be used for splitting.

4.3.4 *Phase Information and Peak Splittings:*

4.3.4.1 In practice, the same empirical approach described for frequency shifts is used to identify diagnostic modes whose splittings correlate with the size of a defect of interest. The sensitivity of this type of measurement is enhanced by the interference, which occurs between closely-spaced peaks. The destructive interference develops into a visible spectral splitting which would not be noticeable with the amplitude spectrum (the real and quadrature components add to form the amplitude response). Most commercial systems function reasonably well without this attribute, but the problem can be exacerbated when the material exhibits resonance line widths which are greater than 1 % of the frequency. Under such circumstances, it may be impossible to detect splittings without phase information.

4.3.4.2 Degenerate modes all have the same phase at low-symmetry points; therefore, if one mode is shifted slightly destructive interference occurs between them, showing up as a splitting if the sample rigidity is sufficient. The frequency difference between the two resulting peaks increases in direct proportion to the defect size. This does not hold for accidental degeneracies, which are modes that by coincidence rather than by symmetry have the same frequency. The actual shift in frequency is no more than would be expected for an isolated mode, but the interference enhances the visibility.

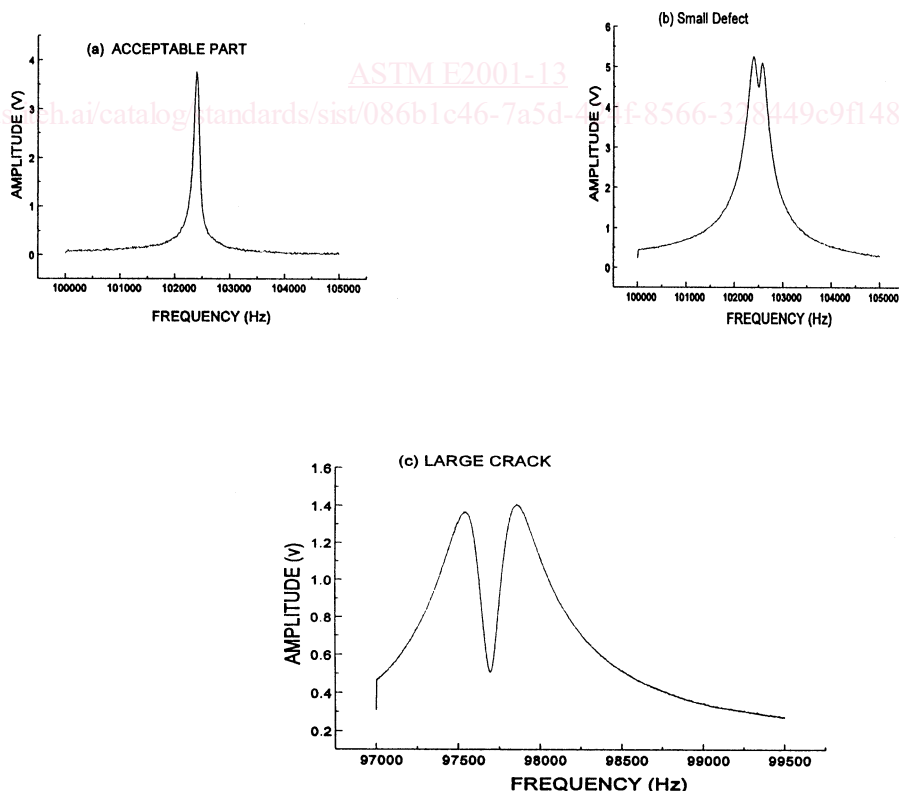

FIG. 3 Shown is a Bending Mode Within a Resonance Spectrum of an Acceptable Steel Cylinder (a), One With a Small Defect (b), and One With a Large Crack (c).