



Standard Specification for Air Performance Measurement Plenum Chamber for Vacuum Cleaners¹

This standard is issued under the fixed designation F 431; the number immediately following the designation indicates the year of original adoption or, in the case of revision, the year of last revision. A number in parentheses indicates the year of last reapproval. A superscript epsilon (ϵ) indicates an editorial change since the last revision or reapproval.

1. Scope

1.1 This specification covers the acceptable details and tolerances for the plenum chamber used in specified air performance measurement tests for vacuum cleaners.

1.2 The plenum chamber is designed for vacuum measurements only.

1.3 The foot-pound, inch system of units is used in this standard. The values in parentheses are given for information only.

2. Referenced Documents

2.1 ASTM Standards:

F 558 Test Method for Measuring Air Performance Characteristics of Vacuum Cleaners²

F 820 Test Method for Measuring Air Performance Characteristics of Central Vacuum Cleaning Systems²

2.2 ASTM Adjunct:

Orifice Plate Holder Details (F 431)³

3. Details

3.1 Plenum chambers conforming to this specification shall be fabricated in accordance with the dimensions, tolerances, and notes shown in the following figures:

3.1.1 Plenum chamber assembly, see Fig. 1.

3.1.2 Orifice plate detail, see Fig. 2.

3.1.3 Orifice plate holder and assembly, see Fig. 3.

3.2 Manometer connection detail, see Fig. 1(f), Note 17.

4. Orifice Plates

4.1 Orifice plates conforming to this specification shall be fabricated in accordance to the dimensions, tolerances, and notes shown in the following figure:

4.1.1 Orifice plate dimensional detail, see Fig. 2(a).

4.1.2 Acceptable machined edges for orifice plates, see Fig. 2(b).

5. Keywords

5.1 air performance; orifice plate; plenum chamber; vacuum cleaner

¹ This specification is under the jurisdiction of ASTM Committee F-11 on Vacuum Cleaners and is the direct responsibility of Subcommittee F11.22 on Air Performance.

Current edition approved Oct. 10, 1998. Published February 1999. Originally published as F 431 – 75. Last previous edition F 431 – 87 (1992) ^{ϵ 1}.

² *Annual Book of ASTM Standards*, Vol 15.07.

³ Available from ASTM Headquarters. Order PCN 12-604310-47.

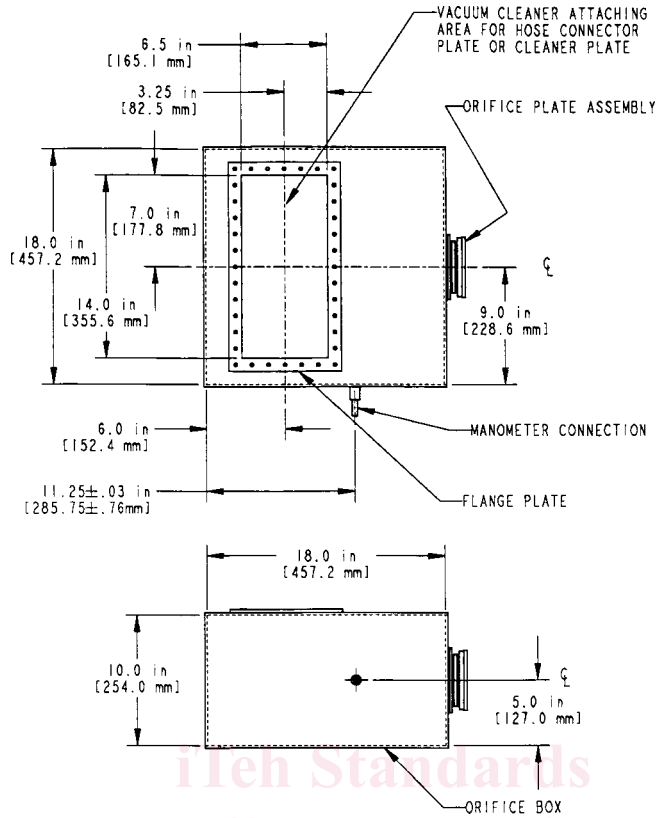

FIG. 1 (a) Plenum Chamber (Material: see Note 8)

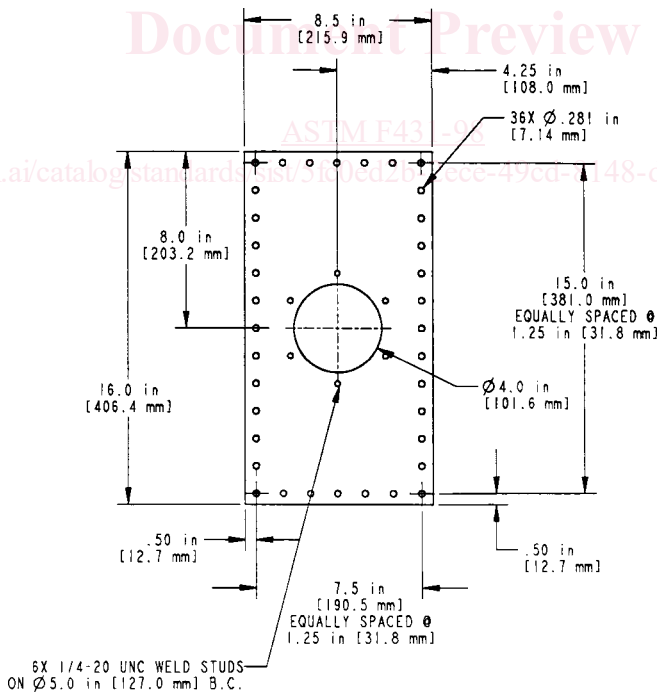

FIG. 1 (b) Hose Connector Plate (Material: 0.250-in. (6.35-mm) Steel) (continued)

ASTM F 431

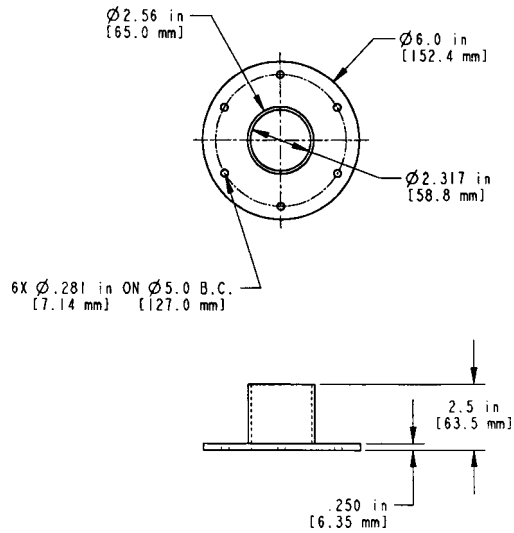

FIG. 1 (c) Hose Connector (Material: Aluminum or Steel—see Note 16) (continued)

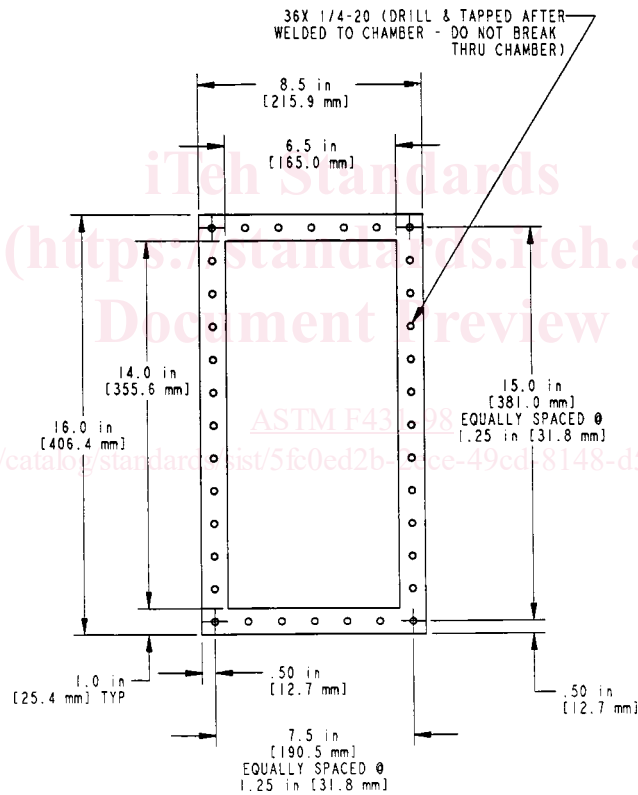

FIG. 1 (d) Flange Plate (Material: 0.250-in. (6.35-mm) Steel) (continued)

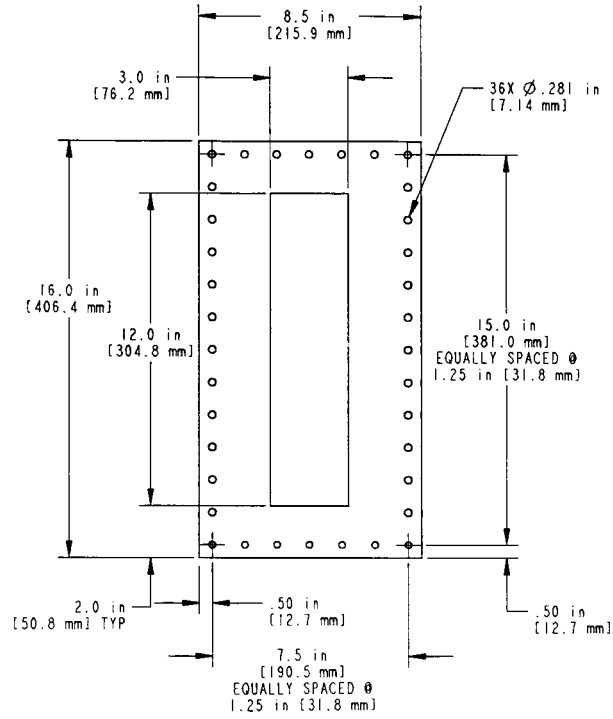

FIG. 1 (e) Cleaner Plate (Material: 0.250-in. (6.35-mm) Steel) (continued)

iteh Standards
(<https://standards.iteh.ai>)
Document Preview

ASTM F431-98

<https://standards.iteh.ai/catalog/standards/sist/5fc0ed2b-2ece-49cd-8148-d55e7696a5d6/astm-f431-98>

ASTM F 431

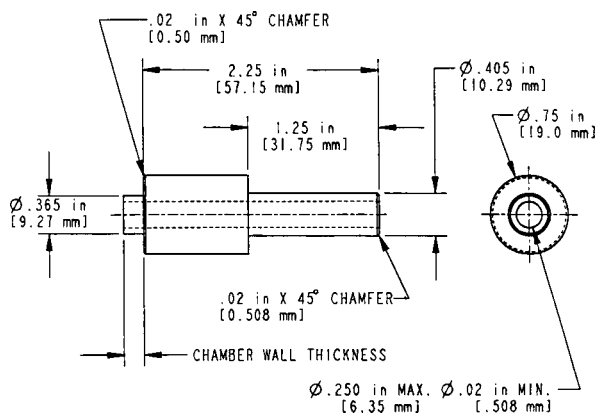

- NOTE 1—All dimensions are measured from inside surfaces.
- NOTE 2—Interior must be clean, smooth, and free of projections or recesses on walls or attachment openings. Internal bracing should not be used to support plenum chamber walls.
- NOTE 3—Attachment port edge to be smooth and well rounded.
- NOTE 4—Orifice box must withstand 180 in. of water (336 mm Hg) negative static pressure without significant distortion of walls or joints after chamber is completely fabricated and attachment made.
- NOTE 5—All joints and connections must be airtight.
- NOTE 6—Tolerances (unless otherwise specified): one-place decimal ± 0.031 in. (0.080 mm); two-place decimal ± 0.01 in. (0.25 mm); three-place decimal ± 0.005 in. (0.13 mm).
- NOTE 7—Flange plate and manometer connection to be welded to chamber completely around the sides.
- NOTE 8—Plenum chamber minimum material specification 0.187 in. (4.75 mm) thick low carbon steel.
- NOTE 9—0.060 in. (1.52 mm) thick rubber seal dimensioned similar to flange plate should be used to seal cleaner and hose connector plates.
- NOTE 10—Bore 0.375 in. (9.54 mm) through hole in plenum chamber for manometer connection and 3.000-in. (76.20-mm) diameter hole for orifice plate assembly.
- NOTE 11—All mating holes to be concentric to within 0.005 in. (0.13 mm) T.I.R. after assembly.
- NOTE 12—A 0.060-in. (1.52-mm) thick rubber seal dimensioned similar to hose connector should be used to seal the hose connector plate to hose connector.
- NOTE 13—Six 1/4-20 UNC-2B hex nuts or wing nuts should be used to fasten hose connector to hose connector plate.
- NOTE 14—Thirty-six 1/4-20 UNC-2A screws should be used to fasten either the cleaner plate or hose connector flange plate.
- NOTE 15—Alternative materials, thicknesses, and construction methods may be used; however, requirements of Notes 2 and 4 and all internal dimensions must be complied with.
- NOTE 16—Hose connector internal diameter and length may be changed to accommodate specific hose construction.
- NOTE 17—If a water column manometer or electronic pressure gauge without integration is used, it is recommended that the inner diameter of the manometer connection port be 0.020 in. or as small as possible to minimize manometer overshoot and bounce. As an alternative to fabricating this hole diameter, a hypodermic needle with an inner diameter of 0.020 in. may be placed in the line between the plenum box and the manometer.

FIG. 1 (f) Manometer Connection (Material: Steel) (continued)

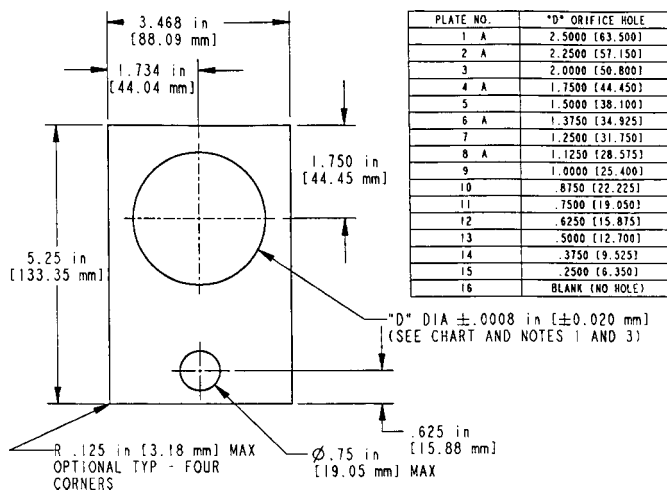
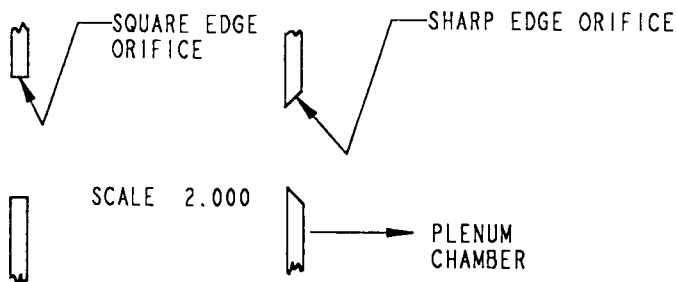

FIG. 2 (a) Orifice Plate



NOTE 1—Proper installation of the sharp orifice into the holder assembly of the plenum chamber is with the sharp edge away from the chamber. Installing the sharp edge orifice toward the chamber may produce incorrect results.

NOTE 2—The circular sharp edge orifice should have neither wire edges nor burrs and is considered sharp if, when viewed with the naked eye, the edge does not seem to reflect a beam of light. The maximum diameter used shall not exceed 2.500 in. (60.350 mm) in diameter.

NOTE 3—Tolerance (unless other specified): one-place decimal ± 0.031 in. (0.80 mm); two-place decimal ± 0.010 in. (0.25 mm); three-place decimal ± 0.005 in. (0.13 mm).

NOTE 4—The sizes of orifice plates required by Test Methods F 558 and F 820 are Plate Numbers 3, 5, 7, 9, 10, 11, 12, 13, 14, 15, and 16 (orifice plate nos. 1, 2, 4, 6, and 8 are optional).

NOTE 5—AISI 4130 steel hardened to RC 42 to 47, finish black oxide, or 316 stainless steel plate 0.0595 ± 0.0030 in. (1.511 ± 0.076 mm) thick.

FIG. 2 (b) Side View, Orifice Plate (continued)

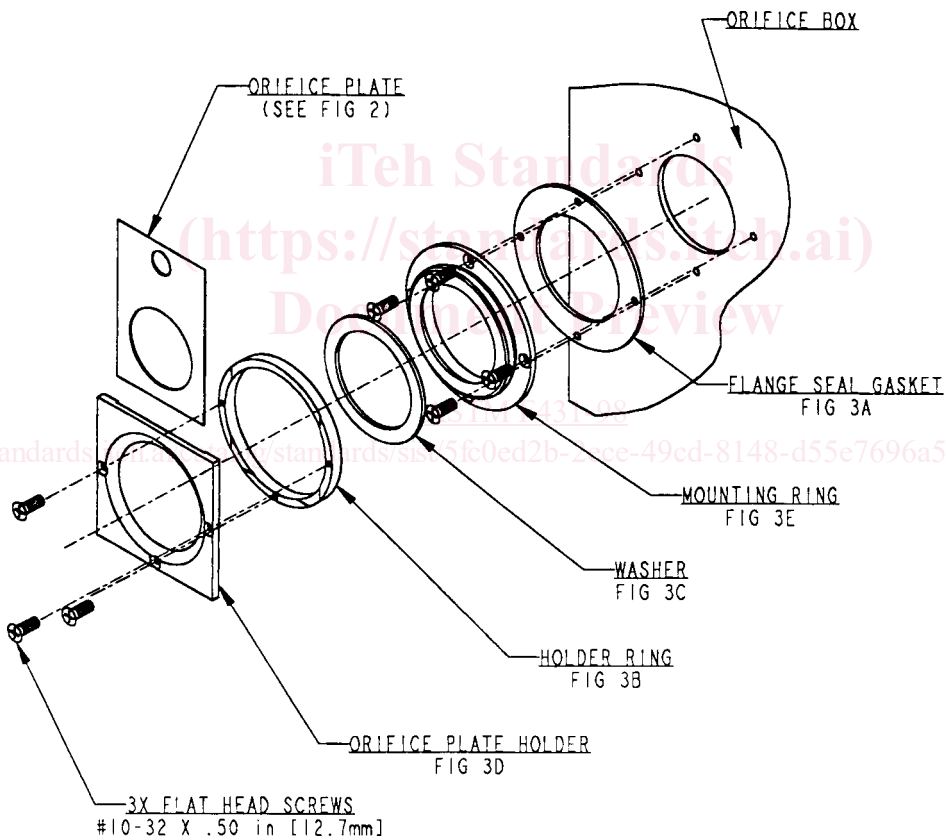

FIG. 3 Orifice Plate Holder Assembly