



Standard Specification for Roof and Rock Bolts and Accessories¹

This standard is issued under the fixed designation F 432; the number immediately following the designation indicates the year of original adoption or, in the case of revision, the year of last revision. A number in parentheses indicates the year of last approval. A superscript epsilon (ϵ) indicates an editorial change since the last revision or reapproval.

1. Scope

1.1 This specification covers the chemical, mechanical, and dimensional requirements for roof and rock bolts and accessories. Addressed in this specification are double-end threaded and slotted steel bars; fully grouted bolts and threaded bars; mechanical anchorage devices used for point anchorage applications; roof truss systems; partially grouted deformed bolts; formable anchorage devices; and other frictional anchorage devices. All of these products represent various designs used for ground support systems. This specification can be revised to address new technologies.

1.2 The values stated in inch-pound units are to be regarded as the standard. The values given in parentheses are for information only.

1.3 This hazard statement applies only to Section 10, Test Methods of this specification. *This standard does not purport to address the safety concerns, if any, associated with its use. It is the responsibility of the user of this standard to establish appropriate safety and health practices and determine the applicability of regulatory limitations prior to use.*

2. Referenced Documents

2.1 ASTM Standards:

- A 29/A 29M Specification for Steel Bars, Carbon and Alloy, Hot-Wrought and Cold-Finished, General Requirements for²
- A 47 Specification for Ferritic Malleable Iron Castings³
- A 194/A 194M Specification for Carbon and Alloy Steel Nuts for Bolts for High-Pressure and High-Temperature Service⁴
- A 220 Specification for Pearlitic Malleable Iron³
- A 370 Test Methods and Definitions for Mechanical Testing of Steel Products⁵
- A 536 Specification for Ductile Iron Castings³

- A 563 Specification for Carbon and Alloy Steel Nuts⁶
 - A 568/A 568M Specification for Steel, Sheet, Carbon, and High-Strength, Low-Alloy, Hot-Rolled and Cold-Rolled, General Requirements for⁵
 - A 615 Specification for Deformed and Plain Billet-Steel Bars for Concrete Reinforcement⁷
 - A 751 Test Methods, Practices, and Terminology for Chemical Analysis of Steel Products⁵
 - D 1248 Specification for Polyethylene Plastics Molding and Extrusion Material⁸
 - F 436 Specification for Hardened Steel Washers⁶
 - F 606 Test Methods for Determining the Mechanical Properties of Externally and Internally Threaded Fasteners, Washers, and Rivets⁶
- #### 2.2 ASME Standards:
- B 1.1 Unified Screw Threads⁹
 - B 1.3M Screw Thread Gaging Systems for Dimensional Acceptability—Inch and Metric Screw Threads⁹
 - B 18.2.2 Square and Hex Nuts⁹

3. Terminology

3.1 Definitions:

3.1.1 *bearing plates, plate washers, mine roof plates*—plates that serve to distribute the load from the exposed end of the bolt or threaded bar to the rock face or intermediate member.

3.1.1.1 *header plates*—large rectangular bearing plates, usually 6 in. (152 mm) wide by 16 to 18 in. (406.4 to 457.2 mm) long, or any other shape with an equivalent area, used in substitution for wooden header blocks for wider distribution of the bolt load than is possible with standard bearing plates.

3.1.2 *bendable bolts*—bolts furnished with an altered section at some location, to be specified by the customer, at which the bar will bend.

3.1.2.1 *Discussion*—Bending is necessary to permit installation of bars longer than the mine opening height. This altered section may be produced by hot or cold forging, or by shearing, sawing, trimming, machining, grinding, or a combination of these processes.

¹ This specification is under the jurisdiction of ASTM Committee F16 on Fasteners and is the direct responsibility of Subcommittee F16.02 on Steel Bolts, Nuts, Rivets, and Washers.

Current edition approved Jan. 13, 1995. Published March 1995. Originally published as E 53 – 75. Last previous edition F 432 – 94.

² *Annual Book of ASTM Standards*, Vol 01.05.

³ *Annual Book of ASTM Standards*, Vol 01.02.

⁴ *Annual Book of ASTM Standards*, Vol 01.01.

⁵ *Annual Book of ASTM Standards*, Vol 01.03.

⁶ *Annual Book of ASTM Standards*, Vol 01.08.

⁷ *Annual Book of ASTM Standards*, Vol 01.04.

⁸ *Annual Book of ASTM Standards*, Vol 08.01.

⁹ Available from ASME International, Information Central, 22 Law Dr., PO Box 2300, Fairfield, NJ 07007-2300.

3.1.3 *beveled washers*—washers whose faces are at an angle permitting a headed bolt or threaded bar to be installed at a slight angle to the rock face and yet maintained the face of the bolt head perpendicular to the bolt axis.

3.1.4 *chemical anchors*—chemical materials that provide anchorage between the bolt or bar and the drilled hole.

3.1.5 *expansion shells*—anchorage devices that expand to grip the sides of a drilled hole mechanically and transfer load from the location of the anchor to the bar or bolt.

3.1.6 *extensions*—threaded bars used to extend the length of threaded or threaded slotted bars.

3.1.7 *formable anchorage devices*— any roof support devices that provide anchorage through some means of physical interference and engagement of the surface of a bar or bolt with any formable material, other than chemical grout, in a bore-hole.

3.1.8 *frictional anchorage devices*— roof support devices that are designed so that the holding force acts over the full contact length.

3.1.9 *fully grouted bolts and threaded bars*—deformed bars or plain bars used with full-length grouting and having special deformations or other design features to provide interlocking between the steel and the grout.

3.1.10 *hardened washers*—washers that have been hardened by heat treatment to provide consistency to the torque tension relation necessary to control installation tension of bolts and threaded bars.

3.1.11 *minimum non-seizure load (MNSL)*—the load level in pounds through which bolt/plug thread seizure must not occur.

3.1.12 *minimum ultimate load (MUL)*—the load level in pounds through which bolt/plug thread failure must not occur.

3.1.13 *rollers, cams*—moving devices that, when used with internally threaded cylinders containing external tapered slots, provide expansion to grip the sides of a drilled hole mechanically and transfer load from the location of the anchor to the bar or bolt.

3.1.14 *roof and rock bolts*—headed hot-rolled bars with cold-rolled or machine-cut threads at the end, to be used with anchorage devices to hold up mine roofs, hold back walls, or hold down equipment or foundations.

3.1.15 *roof truss system*—a roof support system incorporating bolts that are joined together by crossmember(s) that is (are) tensioned by design.

3.1.16 *spherical washers or seats*—washers that are flat on one side and have a spherical face on the other side. The combination of spherical washer together with a depression in the bearing plate produces a ball-and-socket joint permitting bolts to be installed at a slight angle to the rock face while still maintaining the face of the bolt head perpendicular to the bolt axis.

3.1.17 *tapered wedges*—plain wedges that provide the expansion for threaded slotted bars.

3.1.18 *tension nuts*—nuts that are intended to induce and maintain tension in a bolt.

3.1.19 *threaded bars*—bars that are used with a nut on one end and an anchorage device on the other. They are used in a manner similar to the bolts described in 3.1.14.

3.1.20 *threaded couplings*—couplings used to permit the assembly of additional externally threaded items.

3.1.21 *threaded slotted bars*—bars threaded at one end each with a forged, burned, or sawed slot at the other, into which a tapered wedge can be inserted. When each assembly is driven into a bottomed hole, the wedge spreads the slot and an anchorage is produced.

3.1.22 *threaded tapered plugs*—threaded wedge that expands the expansion shell by the movement of the threaded plug within the shell as tightening progresses.

4. Ordering Information

4.1 Orders for material under this specification shall include at least the following information:

4.1.1 Quantity (number of pieces),

4.1.2 Name of product together with description of accessories,

4.1.3 Dimensions,

4.1.4 ASTM designation and year of issue, including strength grade,

4.1.5 Special requirements, if any, including packaging and thread protection instructions, and

4.1.6 Certifications, if required.

4.2 The products covered by this specification are currently produced by many manufacturers to a wide variety of designs. It is necessary for the user and the manufacturer to establish the requirements of the individual installation and to agree as to the type of assembly to be employed. See Annex A1 and Appendix X1 for additional information.

5. Manufacturing Processes

5.1 *Materials for Bolts, Extensions, and Threaded or Threaded Slotted Bars:*

5.1.1 Steel shall conform to the requirements shown in Table 1 and in Specification A 29 for plain bars or Specification A 615 for plain or deformed bars unless otherwise specified.

5.1.1.1 Threaded slotted bars may have the slot produced by forging, burning, or sawing. Burned slots of Grades 55 and 75 threaded slotted bars must have the slotted end normalized by

TABLE 1 Chemical Requirements

Product	Carbon, max, %		Sulfur, max, %		Phosphorus, max, %	
	Heat	Product	Heat	Product	Heat	Product
Bolts, threaded bars, and threaded slotted bars ^A	0.75	0.79	0.13	^B	0.050	0.058
Steel tapered wedges	0.80	0.84	0.13	^B	0.050	0.058
Hardened spherical, flat, or beveled washers	0.80	0.84	0.050	0.058	0.050	0.058
Spherical or beveled washers	0.80	0.84	0.050	0.058	0.050	0.058
Bearing and header plates	1.00	1.04	0.050	0.058	0.050	0.058
Steel threaded tapered plugs	0.60	0.64	0.13	^B	0.050	0.058
Steel expansion shells	0.30	0.33	0.050	0.058	0.050	0.058

^ABars furnished in accordance with Specification A 615 may be substituted for these requirements.

^BCheck analysis for sulfur if a resulfurized steel is not technically appropriate.

heating to a minimum of 1600°F (870°C) and air cooling subsequent to burning.

5.1.1.2 Threads on bolts or threaded bars may be cold rolled or machine cut on the hot-rolled bars.

5.2 *Materials for Tapered Wedges for Use With Threaded Slotted Bars:*

5.2.1 Malleable iron casting shall conform to Specification A 47.

5.2.2 Pearlitic malleable iron castings shall conform to Specification A 220, Grades 45006 or 50005.

5.2.3 Steel shall conform to the requirements shown in Table 1.

5.3 *Materials for Expansion Shells:*

5.3.1 Malleable iron castings shall conform to Specification A 47.

5.3.2 Steel shall conform to the requirements shown in Table 1.

5.3.3 Ductile iron castings shall conform to Specification A 536, Grades 60-40-18.

5.4 Materials for threaded tapered plugs used with expansion shells shall conform to the test specifications in 10.8.

5.5 *Materials for Bearing and Header Plates, Also Known As Plate Washers or Mine Roof Plates:*

5.5.1 Steel shall conform to the requirements shown in Table 1.

5.5.1.1 Bearing and header plates may be strengthened by cold forming or may be hardened by quenching in a liquid medium from above the austenitizing temperature and tempering at a temperature of not less than 650°F (345°C).

5.6 *Materials for Spherical, Flat, or Beveled Hardened Washers:*

5.6.1 Steel shall conform to the requirements shown in Table 1.

5.6.1.1 Hardened steel washers shall be through hardened by quenching in a liquid medium from above the austenitizing temperature and tempering at a temperature of not less than 650°F (345°C). Case-hardened washers are not permitted.

5.7 *Materials for Spherical or Beveled Washers:*

5.7.1 Malleable iron castings shall conform to Specification A 47.

5.7.2 Pearlitic malleable iron castings shall conform to Specification A 220, Grades 45006, 50005, or 60004.

5.7.3 Steel shall conform to the requirements shown in Table 1.

5.8 Nuts shall be in accordance with Specification A 194 or A 563. Appropriate nuts for each grade of threaded bar are shown in Table 2. Higher strength nuts conforming to Specifications A 194 or A 563 may be substituted. When specified on the order or contract, nuts with external dimensions of nominal 3/4-in. heavy hex or heavy square size may be supplied with 5/8-in. threads for use with 5/8-in. threaded bars.

5.9 Chemical grouting materials are covered in Annex A3 of this specification.

5.10 Materials for threaded couplings shall be selected by the manufacturer to ensure compliance with 7.6 and 8.7.

5.11 *Materials for Bolts and Threaded Bars for Use in Grouted Systems*—Plain or deformed steel bars shall conform to Table 1 or Specification A 615.

5.12 *Materials for Frictional Anchorage Devices*—Sheet steel shall conform to Specification A 568/A 568M.

5.13 Components of roof truss systems shall be manufactured in accordance with the appropriate paragraph(s) of Section 5 of this specification.

5.14 *Materials for Formable Anchors:*

5.14.1 Materials for formable anchor tubes are as follows:

5.14.1.1 Polyethylenes used for formable anchor tubes shall conform to ASTM D 1248 Classification Type III, Class A or B, Category 5.

NOTE 1—All shapes, compositions, and properties of formable anchor materials are not covered by this specification. Users must ensure that the formable anchor material offered is suitable for its intended use.

6. Chemical Composition

6.1 Materials used for bolts, threaded bars, threaded slotted bars, spherical, flat, or beveled washers, threaded tapered plugs, tapered wedges, expansion shells, bearing plates and roof truss components shall be as specified in Table 1 and Section 5.

6.2 Materials for all cast or wrought metallic items other than those covered in 6.1 shall conform to the requirements as specified in Section 5.

6.3 Individual heats of steel or cast iron are not identified in any of the finished products.

6.4 Chemical analyses for steel products shall be performed in accordance with Test Methods A 751.

6.5 Materials for formable anchors shall conform to the requirements, if applicable, specified in Section 5.

6.6 Chemical analyses shall be performed in accordance with Test Methods A 751.

7. Mechanical Properties

7.1 Mechanical properties of steel bars, for the manufacture of bolts, threaded bars, or threaded slotted bars shall be as specified in Table 3 for the required grade.

7.2 Mechanical properties of steel bolts, threaded bars, and threaded slotted bars whose slots have been produced without material removal shall be as specified in Table 4 for the required grade.

7.3 Expansion shells, threaded tapered plugs, tapered wedges, and spherical washers shall conform to the applicable specification of Section 5 and shall successfully perform the required purpose as described in Annex A1.

7.4 Bearing plates and header plates that are strengthened by quenching and tempering shall have a maximum hardness of 45 HRC.

7.4.1 Bearing plates and header plates shall be provided in 10 000-lbf (44.5-kN) grade increments. The minimum grade rating permitted shall be 20 000 lbf (89.0 kN).

7.5 Hardened washers shall have a hardness range from 35 to 45 HRC.

TABLE 2 Appropriate Nuts

Bolt, Threaded Bar, or Threaded Slotted Bar Grade	Nut Specification
30 (regular strength)	A 194, Grade 1; A 563, Grade B
55 (high strength)	A 194, Grade 1; A 563, Grade B
75 (extra high strength)	A 194, Grade 2; A 563, Grade C



TABLE 3 Mechanical Properties of Steel Bars for the Manufacture of Bolts, Threaded Bars, and Threaded Slotted Bars^{AB}

Grade	Nominal Diameter, in. ^C	Yield Point min, psi (MPa)	Tensile Strength min, psi (MPa)	Elongation in 8 in. or 200 mm Minimum, %
40 ^D	¾ – 1½	40 000 (276)	70 000 (483)	12
55	¾ – 1½	55 000 (379)	85 000 (586)	12
60 ^D	¾ – 1½	60 000 (414)	90 000 (621)	9
75	¾ – 1½	75 000 (517)	100 000 (688)	8
100	¾ – 1½	100 000 (689)	125 000 (862)	6

^ATest of bars shall be performed full size.

^BHigher grades would be produced in 20 000-psi increments. The minimum tensile strength shall be 25 000 psi above the minimum yield strength. The minimum elongation shall be 4 % for all grades above 100.

^CActual bar diameters are somewhat less than nominal, especially when roll threading methods are employed.

^DGrade 40 and 60 only apply to deformed bar.

7.6 Threaded couplings must be capable of developing the actual yield and tensile values of the bolt, threaded bar, or threaded slotted bar with which they are to be used.

7.7 Extensions must be in accordance with 7.1 and 7.2 for the grade of item specified.

7.8 Mechanical properties for bolts and threaded bars for use in grouted systems shall be as specified in Table 3 for plain bars; and Table 3 or Specification A 615 for deformed bars. Bolts and threaded bars made from plain material must contain some design feature to provide interlocking between the steel and the grout. These items can be supplied threaded or headed.

7.9 Threaded slotted bars whose slots have been produced by burning shall be heat treated by normalizing in accordance with 5.1.1. The normalizing heat treatment and the removal of material from the slot, whether it be by burning or sawing, will result in lower test values. When either the burning or sawing or other methods involving metal removal are used, the mechanical properties of threaded slotted bolts shall be as specified in Table 5.

7.10 Threaded tapered plugs for expansion anchors must be capable of withstanding the minimum nonseizure load (MNSL) and minimum ultimate load (MUL), in accordance with Table 6.

7.11 Tension nuts must be capable of withstanding the ultimate tensile strength of the bolt or rebar of the highest grade with which they are to be used.

7.12 The mechanical properties of components of roof truss systems shall be in accordance with the appropriate paragraph(s) of this section.

7.12.1 Truss brackets shall be provided in 10 000-lbf (44.5-kN) grade increments.

7.13 Formable anchor materials shall conform to the applicable specifications of Section 5.

8. Dimensions, Mass, and Permissible Variations

8.1 Threaded bolts shall conform to the dimensions shown in Fig. 1.

8.1.1 Deformed bar bolts are bars that have been forged to produce one of the standard heads described in Fig. 1.

8.2 Threaded and threaded slotted bars shall conform to the dimensions shown in Fig. 2.

8.3 *Thread Requirements:*

NOTE 2—Thread size variations can be expected due to bar diameter and out-of-round variations. These special requirements reflect practices for external and internal threads that have been found to provide adequate strength and interchangeability.

8.3.1 External threads shall be in accordance with AMSE B 1.1 UNC 1A except that the minimum pitch diameter has been reduced by 0.003 in. (0.08 mm) and the minimum major diameter has been reduced 0.010 in. (0.25 mm) to reflect the normal variations expected on hot-rolled bars due to the combined effect of bar diameter and out-of-round tolerances. Information on this increased tolerance is described in Note 3. The modified requirements are listed in Table 7.

NOTE 3—External threads that are to be used with threaded tapered plugs in expansion anchors are permitted to have somewhat increased pitch and major diameter tolerance. As bolt load is increased, the tendency for thread failure through nut diametrical expansion normally increases; however, in the case of threaded tapered plugs, increased load is accompanied by an increasing compression of the internal threads onto the external threads. This compensation for decreased major diameter is further augmented by the length of engagement which is longer than for standard nuts. Nuts to be used with threaded bars and threaded slotted bars shall be selected to provide adequate strength under these thread conditions.

8.3.2 Internal threads in threaded tapered plugs and threaded couplings shall be in accordance with ASME B 1.1 UNC 1B except that the threads shall be tapped oversize. This oversize is an increase in the pitch diameter of 0.003 in. (0.08 mm) to allow for handling damage on the external thread and dirt and long engagement in the internal thread. The maximum minor diameters are standard 1B for 1½ to 3 diameter length of engagement. The modified requirements are listed in Table 7.

8.3.3 Internal threads in nuts shall be tapped standard UNC 2B size in accordance with ASME .1 or may be tapped oversize in accordance with 8.3.2 with agreement of producer and purchaser.

8.3.4 Gaging of threads shall be performed in accordance with System 21, ASME B 1.3M. Pitch diameter and thread crest diameter limits are specified in Table 7.

8.3.5 Threaded tapered plugs shall have a tapped length at least equal to one times the nominal bolt diameter with which they are to be used.

8.3.6 Threaded couplings shall have a tapped length at least equal to two times the nominal bolt diameter with which they are to be used.

8.4 Round and square hardened washers shall be as shown in Fig. 3.

8.4.1 There are two types of hardened flat washers available. Type 1 is to be furnished unless otherwise specified.

8.4.1.1 Type 1 is either circular or square as shown in Fig. 3. It is designed for use with plate washers containing 1¾-in. (35-mm) holes, but may be used for all smaller hole sizes.

8.4.1.2 Type 2 is the hardened flat washer in accordance with Specification F 436. It may be used only when sufficient clearance is available between the threaded-bar or threaded-rolled-bar body diameter near the head and the washer hole. This washer is not suitable for use with plate washers that contain holes that are more than ¾ in. (9.5 mm) greater in diameter than the nominal bolt diameter.

TABLE 4 Load Support Requirements of Steel Bolts, Threaded Bars, (see Annex A2) Threaded Deformed Bars, and Threaded Slotted Bars Whose Slot Has Been Produced Without Metal Removal^A

N = Newton
kN = kiloNewton
1 lb = 4.448 N or 0.004448 kN

Nominal Diameter (in.)/Thread /in.	Thread Stress Area, in. ² (mm ²)	Grade									
		40 ^B		55		60 ^B		75		100	
		Yield lbs (kN) ^C	Ultimate lbs (kN) ^C	Yield lbs (kN) ^C	Ultimate lbs (kN) ^C	Yield lbs (kN) ^C	Ultimate lbs (kN) ^C	Yield lbs (kN) ^C	Ultimate lbs (kN) ^C	Yield lbs (kN) ^C	Ultimate lbs (kN) ^C
5/8 –11	0.226 (1.46)	<i>D</i>	<i>D</i>	12 400 (55.16)	19 200 (85.4)	13 600 (60.50)	20 300 (90.30)	17 000 (75.6)	22 600 (100.5)	22 600 (100.5)	26 300 (130.8)
3/4 –10	0.334 (2.65)	13 400 (59.60)	23 400 (104.08)	18 400 (81.8)	28 400 (126.3)	20 000 (89.0)	30 100 (133.9)	25 100 (111.6)	33 400 (148.6)	33 400 (148.6)	41 800 (193.5)
7/8 –9	0.462 (2.96)	18 500 (82.3)	32 300 (143.7)	25 400 (113.0)	39 300 (174.8)	27 700 (123.2)	41 600 (185.0)	34 700 (154.3)	46 200 (205.5)	46 200 (205.5)	57 800 (267.3)
1 –8	0.606 (3.91)	24 200 (107.6)	42 400 (188.6)	33 300 (148.1)	51 500 (229.0)	36 400 (161.9)	54 500 (242.4)	45 500 (202.4)	60 600 (269.5)	60 600 (269.5)	75 800 (350.5)
1 1/8 –7	0.763 (4.92)	30 500 (135.7)	53 400 (237.5)	42 000 (186.8)	64 900 (286.7)	45 800 (203.7)	68 700 (305.6)	57 200 (254.4)	76 300 (339.4)	76 300 (339.4)	95 400 (441.2)
1 1/4 –7	0.969 (6.25)	38 800 (172.6)	67 800 (301.6)	53 300 (237.1)	82 400 (366.5)	58 100 (258.4)	87 200 (387.9)	72 700 (323.4)	96 900 (431.0)	96 900 (431.0)	121 100 (560.4)
1 3/8 –6	1.155 (7.45)	46 200 (205.5)	80 900 (359.8)	63 500 (282.4)	96 200 (436.8)	69 300 (308.2)	104 000 (462.6)	86 600 (385.2)	115 500 (513.7)	115 500 (513.7)	144 400 (668.1)
1 1/2 –6	1.405 (9.06)	56 200 (250.0)	98 400 (437.7)	77 300 (343.8)	119 400 (531.1)	84 300 (375.0)	126 500 (562.7)	105 400 (468.8)	140 500 (624.9)	140 500 (624.9)	175 600 (814.6)

^ATests of bolts and threaded bars shall be performed using full-diameter products.

^BInformation for Gr 40 and 60 only applies to deformed bars.

^CRequired yield and tensile loads shown are calculated by multiplying thread stress areas times the yield point and tensile strength values shown in Table 3. Thread stress area is calculated from the mean root and pitch diameters of adrenal threads as follows:

$$A_s = 0.7854 \left(D - \frac{0.9743}{n} \right)^2$$

where:

A_s = stress area, in.²

D = nominal diameter, in., and

n = number of threads per inch.

^D5/8 in. Gr 40 products are not covered.

TABLE 5 Load Support Requirements for Threaded Slotted Bars Whose Slot Has Been Produced by Methods Involving Metal Removal^A

Nominal Diameter, in.	Thread Stress Area, min, in. ² (mm ²)	Grade 55	
		Yield Load, min, lbf (kN) ^B	Ultimate Tensile Load, min, lbf (kN) ^B
1	0.606 (3.91)	30 000 (133.3)	46 400 (206.2)
1 1/4	0.969 (6.25)	48 000 (213.4)	74 200 (329.9)
1 3/8	1.155 (7.45)	57 200 (254.2)	88 400 (393.1)
1 1/2	1.405 (9.06)	69 600 (309.4)	107 500 (478.0)

^ATests of bolts, threaded bars, and threaded slotted bars shall be performed using full-diameter products.

^BRequired yield and tensile loads shown are calculated by multiplying thread stress areas times the yield point and tensile strength values shown in Table 2. Thread stress area is calculated from the mean of the mean root and pitch diameters of Class 3 external threads as follows:

$$A_s = 0.7854 \left(D - \frac{0.9743}{n} \right)^2$$

where:

A_s = stress area, in.²

D = nominal diameter, in., and

n = number of threads per inch.

8.5 Bearing and header plates may be of any thickness that successfully meets the test requirements in accordance with 10.4. The maximum hole size for use with bolts up to 3/4-in. nominal diameter shall be 1 3/8 in. (35 mm) except that hole size may be 1 1/2 in. (38 mm) when spherical washers or seats are used. Tolerance on hole diameter shall be -0, 1/8 in. (-0, +3.2

TABLE 6 Plug Grade Rating System

Nominal Diameter, in.	Grade 1		Grade 2		Grade 3		Grade 4	
	MNSL ^A	MUL ^B	MNSL ^A	MUL ^B	MNSL ^A	MUL ^B	MNSL ^A	MUL ^B
1/2	7.0	14.2	10.7	17.0	13.5	19.9	16.3	22.7
5/8	12.4	22.6	17.0	27.1	21.5	31.6	26.0	36.1
3/4	18.4	33.4	25.1†	40.1	31.7	46.8†	38.4	53.4†
7/8	25.4†	46.2	34.7	55.4	40.0	64.7	40.0	73.9
1	33.3	60.6	40.0	72.7	40.0	84.8	40.0	96.9
1 1/8	40.0	76.3	40.0	91.6	40.0	106.8	40.0	122.0
1 1/4	40.0	96.9	40.0	116.3	40.0	135.7	40.0	155.0†
1 3/8	40.0	115.5†	40.0	138.6	40.0	161.7	40.0	184.8
1 1/2	40.0	140.5†	40.0	168.6	40.0	196.7	40.0	224.8

^AMNSL—Minimum Non-Seizure Load (1000 lb).

^BMUL—Minimum Ultimate Load (1000 lb).

† Editorially corrected.

mm). Bearing plates for direct bearing applications shall be 6 by 6 in. (152 by 152 mm) with tolerances for length and width of ±1/8 in. Larger bearing plates may be furnished, dimensions and tolerances to be by agreement between the producer and the purchaser. Smaller bearing plates may be used in conjunction with steel channels, with other accessories, or in hard rock areas by agreement between the producer and the purchaser. Header plates are typically 6 in. (152 mm) wide by 16 to 18 in. (406.4 to 457.2 mm) long, or any other shape with an equivalent area.

8.6 Bearing and header plates used with frictional anchorage devices shall meet the test requirements in 10.4. The hole

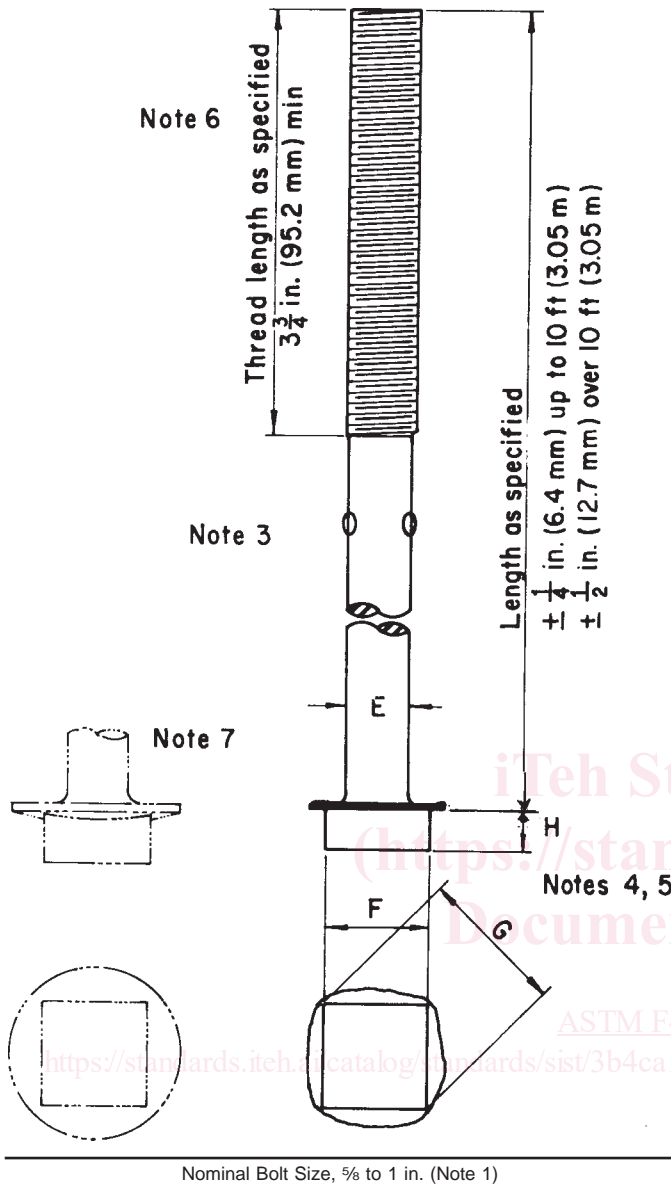

Nominal Bolt Size, 5/8 to 1 in. (Note 1)	
H Head Height, min., in. (mm)	0.476 (12.09)
F Head Across Flats, in. (mm)	1.088 to 1.125 (27.64 to 28.58)
G Head Across Corners, in. (mm)	1.425 to 1.591 (36.19 to 40.41)
E Body diameter is controlled by the roll threading operation.	

Note 1—When specified by the customer on the order or contract, the 5/8-in. diameter bolt may be supplied at:

- H—0.400 (10.16)
- F—0.906 to 0.938 (23.01 to 23.83)
- G—1.244 to 1.326 (31.60 to 33.68)

Note 2—When specified by the customer on the order or contract, a shoulder, collar, or swell equal to the body diameter of a 3/4-in. diameter bolt may be applied under the head of a 5/8-in. diameter bolt for a length of approximately 3/16 in.

Note 3—Pinched ears may be provided to support the expansion shell during installation.

Note 4—Bolt head may have depressed center.

Note 5—See Table 7 for head markings.

Note 6—See Paragraph 8.3.1 for threads.

Note 7—Forging flash is permitted.

FIG. 1 Roof and Rock Bolts

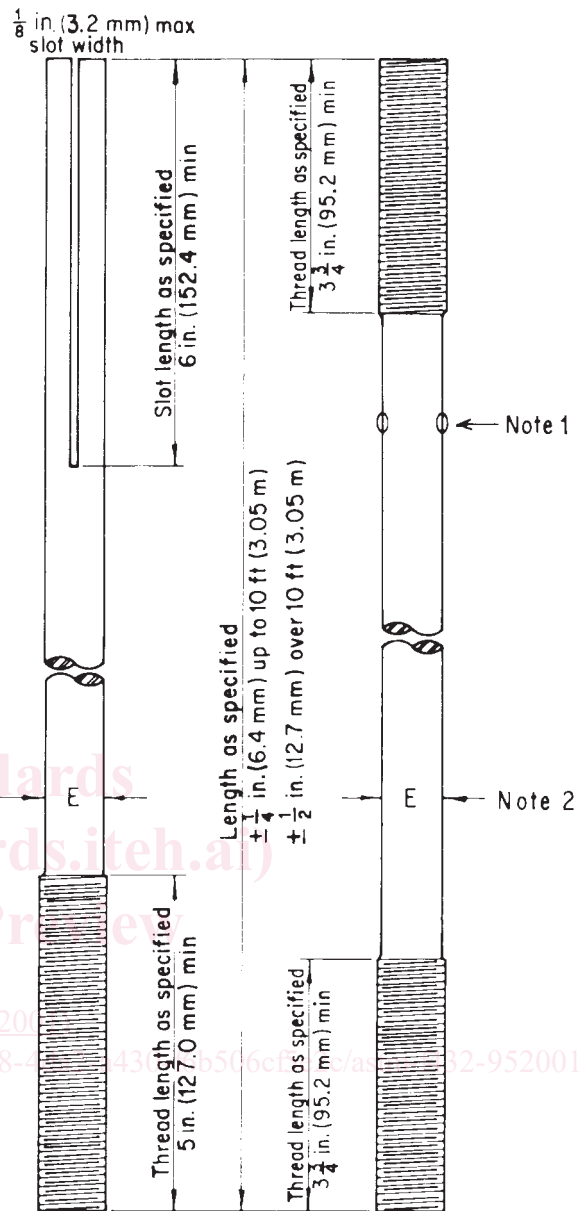

NOTE 1—Pinched ears may be provided to support the expansion shell during installation.

NOTE 2—See 8.3.1 for threads.

NOTE 3—E Body diameter is established by the method of threading.

NOTE 4—Body diameter is controlled by the roll threading operation.

FIG. 2 Threaded Bars and Slotted Threaded Bars

sizes and tolerances shall be set by the manufacturer of the frictional anchorage device.

8.7 Dimensions not otherwise specified for tapered wedges, expansion shells, threaded tapered plugs, beveled washers, spherical washers, threaded couplings, and extensions shall be by agreement between the producer and the purchaser.

8.8 Nuts shall be hex, heavy hex, square, or heavy square in accordance with ASME B 18.2.2. Unless otherwise specified, the heavy series shall be supplied.