



FINAL DRAFT International Standard

Rubber, vulcanized or thermoplastic — Determination of tensile stress-strain properties

*Caoutchouc vulcanisé ou thermoplastique — Détermination des
caractéristiques de contrainte-déformation en traction*

ISO/FDIS 37

ISO/TC 45/SC 2

Secretariat: JISC

Voting begins on:
2024-03-04

Voting terminates on:
2024-04-29

iteh Standards
(<https://standards.iteh.ai>)
Document Preview

<https://standards.iteh.ai>

<https://standards.iteh.ai/catalog/standards/iso/822350bf-13df-413e-97c7-2381578de839/iso-fdis-37>

RECIPIENTS OF THIS DRAFT ARE INVITED TO SUBMIT, WITH THEIR COMMENTS, NOTIFICATION OF ANY RELEVANT PATENT RIGHTS OF WHICH THEY ARE AWARE AND TO PROVIDE SUPPORTING DOCUMENTATION.

IN ADDITION TO THEIR EVALUATION AS BEING ACCEPTABLE FOR INDUSTRIAL, TECHNOLOGICAL, COMMERCIAL AND USER PURPOSES, DRAFT INTERNATIONAL STANDARDS MAY ON OCCASION HAVE TO BE CONSIDERED IN THE LIGHT OF THEIR POTENTIAL TO BECOME STANDARDS TO WHICH REFERENCE MAY BE MADE IN NATIONAL REGULATIONS.

iTeh Standards
(<https://standards.iteh.ai>)
Document Preview

ISO/FDIS 37

<https://standards.iteh.ai/catalog/standards/iso/822350bf-13df-413e-97c7-2381578de839/iso-fdis-37>



COPYRIGHT PROTECTED DOCUMENT

© ISO 2024

All rights reserved. Unless otherwise specified, or required in the context of its implementation, no part of this publication may be reproduced or utilized otherwise in any form or by any means, electronic or mechanical, including photocopying, or posting on the internet or an intranet, without prior written permission. Permission can be requested from either ISO at the address below or ISO's member body in the country of the requester.

ISO copyright office
CP 401 • Ch. de Blandonnet 8
CH-1214 Vernier, Geneva
Phone: +41 22 749 01 11
Email: copyright@iso.org
Website: www.iso.org

Published in Switzerland

Contents

	Page
Foreword.....	v
1 Scope	1
2 Normative references	1
3 Terms, definitions and abbreviated terms	1
4 Principle	4
5 General	4
6 Test pieces	4
6.1 General.....	4
6.2 Dumbbells.....	5
6.3 Rings.....	5
7 Apparatus	6
7.1 Dies and cutters.....	6
7.2 Thickness gauge.....	6
7.3 Cone gauge.....	6
7.4 Tensile-testing machine.....	7
7.5 Test rig for ring test pieces.....	8
8 Calibration	9
9 Number of test pieces	9
10 Preparation of test pieces	9
10.1 Dumbbells.....	9
10.2 Rings.....	9
11 Conditioning of sample and test pieces	10
11.1 Time between vulcanization and testing.....	10
11.2 Protection of samples and test pieces.....	10
11.3 Conditioning of samples.....	10
11.4 Conditioning of test pieces.....	10
12 Marking of dumbbell test pieces	10
13 Measurement of test pieces	10
13.1 Dumbbells.....	10
13.2 Rings.....	11
13.3 Comparison of groups of test pieces.....	11
14 Procedure	11
14.1 Dumbbell test pieces.....	11
14.2 Ring test pieces.....	11
15 Temperature of test	12
16 Calculation of results	12
16.1 Dumbbells.....	12
16.2 Ring test pieces.....	14
17 Expression of results	15
18 Precision	15
19 Test report	15
Annex A (informative) Preparation of type B ring test pieces	17
Annex B (informative) Precision	20
Annex C (informative) Analysis of ITP data and dumbbell shape	26
Annex D (Normative) Calibration schedule	30

iTeh Standards
(<https://standards.itih.ai>)
Document Preview

[ISO/FDIS 37](https://standards.itih.ai/catalog/standards/iso/822350bf-13df-413e-97c7-2381578de839/iso-fdis-37)

<https://standards.itih.ai/catalog/standards/iso/822350bf-13df-413e-97c7-2381578de839/iso-fdis-37>

Foreword

ISO (the International Organization for Standardization) is a worldwide federation of national standards bodies (ISO member bodies). The work of preparing International Standards is normally carried out through ISO technical committees. Each member body interested in a subject for which a technical committee has been established has the right to be represented on that committee. International organizations, governmental and non-governmental, in liaison with ISO, also take part in the work. ISO collaborates closely with the International Electrotechnical Commission (IEC) on all matters of electrotechnical standardization.

The procedures used to develop this document and those intended for its further maintenance are described in the ISO/IEC Directives, Part 1. In particular, the different approval criteria needed for the different types of ISO document should be noted. This document was drafted in accordance with the editorial rules of the ISO/IEC Directives, Part 2 (see www.iso.org/directives).

ISO draws attention to the possibility that the implementation of this document may involve the use of (a) patent(s). ISO takes no position concerning the evidence, validity or applicability of any claimed patent rights in respect thereof. As of the date of publication of this document, ISO had not received notice of (a) patent(s) which may be required to implement this document. However, implementers are cautioned that this may not represent the latest information, which may be obtained from the patent database available at www.iso.org/patents. ISO shall not be held responsible for identifying any or all such patent rights.

Any trade name used in this document is information given for the convenience of users and does not constitute an endorsement.

For an explanation of the voluntary nature of standards, the meaning of ISO specific terms and expressions related to conformity assessment, as well as information about ISO's adherence to the World Trade Organization (WTO) principles in the Technical Barriers to Trade (TBT), see www.iso.org/iso/foreword.html.

This document was prepared by Technical Committee ISO/TC 45, *Rubber and rubber products*, Subcommittee SC 2, *Testing and analysis*.

This seventh edition cancels and replaces the sixth edition (ISO 37:2017), which has been technically revised.

The main changes are as follows:

- a calibration schedule has been added;
- corrections made to black designations;
- symbols changed to comply with the ISO/IEC Directives part 2.

Any feedback or questions on this document should be directed to the user's national standards body. A complete listing of these bodies can be found at www.iso.org/members.html.

Rubber, vulcanized or thermoplastic — Determination of tensile stress-strain properties

WARNING 1 — Persons using this document should be familiar with normal laboratory practice. This document does not purport to address all of the safety problems, if any, associated with its use. It is the responsibility of the user to establish appropriate safety and health practices.

WARNING 2 — Certain procedures specified in this document might involve the use or generation of substances, or the generation of waste, that could constitute a local environmental hazard. Reference should be made to appropriate documentation on safe handling and disposal after use.

1 Scope

This document specifies a method for the determination of the tensile stress-strain properties of vulcanized and thermoplastic rubbers.

The properties which can be determined are tensile strength, elongation at break, stress at a given elongation, elongation at a given stress, stress at yield and elongation at yield. The measurement of stress and strain at yield applies only to some thermoplastic rubbers and certain other compounds.

2 Normative references

The following documents are referred to in the text in such a way that some or all of their content constitutes requirements of this document. For dated references, only the edition cited applies. For undated references, the latest edition of the referenced document (including any amendments) applies.

ISO 5893, *Rubber and plastics test equipment — Tensile, flexural and compression types (constant rate of traverse) — Specification*

ISO 23529:2016, *Rubber — General procedures for preparing and conditioning test pieces for physical test methods*

3 Terms, definitions and abbreviated terms

For the purposes of this document, the following terms and definitions apply.

ISO and IEC maintain terminological databases for use in standardization at the following addresses:

- IEC Electropedia: available at <https://www.electropedia.org/>
- ISO Online browsing platform: available at <https://www.iso.org/obp>

3.1 tensile stress

S

stress applied so as to extend the test piece

Note 1 to entry: It is calculated as the applied force per unit area of the original cross-section of the test length.

3.2 elongation

E

tensile strain, expressed as a percentage of the test length, produced in the test piece by a *tensile stress* (3.1)

**3.3
tensile strength**

S_{max}
maximum *tensile stress* (3.1) recorded in extending the test piece to breaking point

Note 1 to entry: See [Figure 1](#).

**3.4
tensile strength at break**

S_b
tensile stress (3.1) recorded at the moment of rupture

Note 1 to entry: See [Figure 1](#).

Note 2 to entry: The values of TS and TS_b might be different if, after yield at S_y , the *elongation* (3.2) continues and is accompanied by a drop in stress, resulting in TS_b being lower than TS [see [Figure 1 c](#)].

**3.5
elongation at break**

E_b
tensile strain in the test length at breaking point

Note 1 to entry: See [Figure 1](#).

**3.6
elongation at a given stress**

E_s
tensile strain in the test length when the test piece is subjected to a given *tensile stress* (3.1)

**3.7
stress at a given elongation**

S_E
tensile stress (3.1) in the test length required to produce a given *elongation* (3.2)

Note 1 to entry: In the rubber industry, this definition is widely identified with the term “modulus” and care should be taken to avoid confusion with the other use of “modulus” to denote the slope of the stress-strain curve at a given elongation.

**3.8
tensile stress at yield**

S_y
tensile stress (3.1) at the first point on the stress-strain curve where some further increase in strain occurs without any increase in stress

Note 1 to entry: This might correspond either to a point of inflection [see [Figure 1 b](#)] or to a maximum [see [Figure 1 c](#)].

**3.9
elongation at yield**

E_y
tensile strain at the first point on the stress-strain curve where some further increase in strain is not accompanied by an increase in stress

Note 1 to entry: See [Figure 1](#).

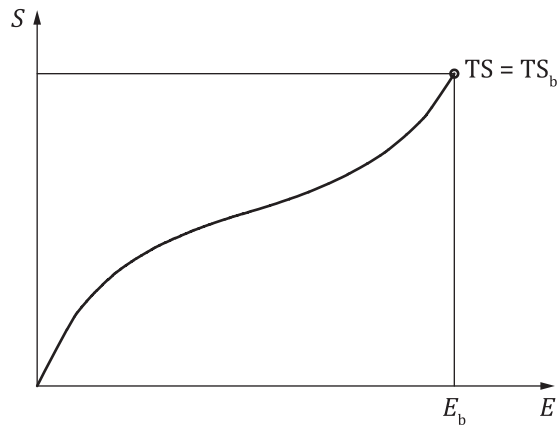

a)

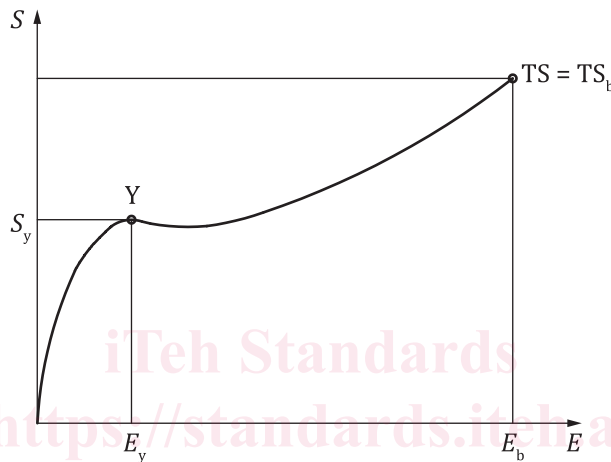

b)

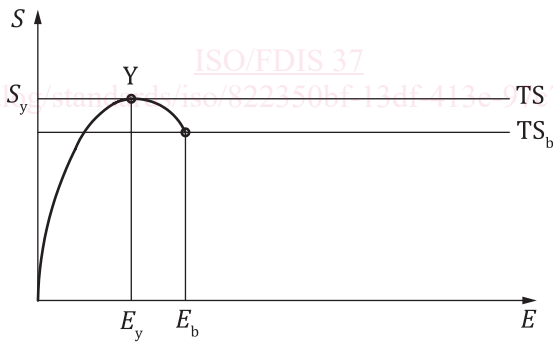

c)

Key

- E elongation
- E_b elongation at break
- E_y elongation at yield
- S stress

- S_y stress at yield
- S_{max} tensile strength
- S_b tensile strength at break
- Y yield point

Figure 1 — Illustration of tensile terms

3.10 test length

initial distance between reference points within the length of the narrow portion of a dumbbell test piece used to measure *elongation* (3.2)

Note 1 to entry: See [Figure 2](#).

4 Principle

Standard test pieces, either dumbbells or rings, are stretched in a tensile-testing machine at a constant rate of traverse of the driven grip or pulley. Readings of force and elongation are taken as required during the uninterrupted stretching of the test piece and when it breaks.

5 General

Dumbbell and ring test pieces do not necessarily give the same values for their respective stress-strain properties. This is mainly because in stretched rings, the stress is not uniform over the cross-section. A second factor is in the existence of “grain” which might cause dumbbells to give different values depending on whether their length is parallel or at right angles to the grain.

The main points to be noted in choosing between rings and dumbbells are as follows.

a) Tensile strength

Dumbbells are preferable for determination of tensile strength. Rings give lower, sometimes much lower, values than dumbbells.

b) Elongation at break

Rings give approximately the same values as dumbbells, provided that

- 1) the elongation of rings is calculated as a percentage of the initial internal circumference, and
- 2) dumbbells are cut at right angles to the grain if this is present to a significant degree.

Dumbbells shall be used if it is required to study grain effects, as rings are not suitable for this purpose.

c) Elongation at a given stress and stress at a given elongation

The larger dumbbells (types 1, 2 and 1A) are generally preferred.

Rings and dumbbells give approximately the same values provided that

- 1) the elongation of rings is calculated as a percentage of the initial mean circumference, and
- 2) the average value is taken for dumbbells cut parallel and at right angles to the grain if this is present to a significant degree.

Rings might be preferred in automated testing, due to the ease of handling of the test pieces, and in the determination of stress at a given strain.

6 Test pieces

6.1 General

Miniature test pieces might give somewhat different, usually higher, values for tensile strength and elongation at break than the larger test pieces.

Seven types of test piece are provided, i.e. dumbbell-shaped types 1, 2, 3, 4 and 1A and ring-shaped types A (normal) and B (miniature). The results obtained for a given material are likely to vary according to the

type of test piece used and the results obtained for different materials should therefore not be regarded as comparable unless the same type of test piece has been used.

When preparation of test pieces requires buffing or thickness adjustment, results might be affected.

6.2 Dumbbells

Dumbbell test pieces shall have the outline shown in [Figure 2](#).

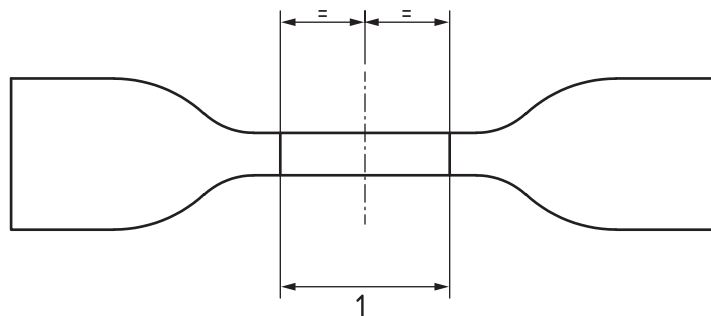

Key

1 test length (see [Table 1](#))

Figure 2 — Shape of dumbbell test pieces

The standard thickness of the narrow portion shall be 2,0 mm ± 0,2 mm for types 1, 2, 3 and 1A and 1,0 mm ± 0,1 mm for type 4.

The test length shall be in accordance with [Table 1](#).

The other dimensions of the dumbbells shall be as produced by the appropriate die (see [Table 2](#)).

For non-standard test pieces, e.g. those taken from finished products, the maximum thickness of the narrow portion shall be 3,0 mm for types 1 and 1A, 2,5 mm for types 2 and 3, and 2,0 mm for type 4.

<https://standards.iteh.ai/catalog/standards/iso-fdis-37> **Table 1 — Test length of dumbbells** <https://standards.iteh.ai/catalog/standards/iso-fdis-37>

Type of test piece	Type 1	Type 1A	Type 2	Type 3	Type 4
Test length (mm)	25 ± 0,5	20 ± 0,5 ^a	20 ± 0,5	10 ± 0,5	10 ± 0,5
^a The test length shall not exceed the length of the narrow portion of the test piece (dimension C in Table 2).					

Type 3 and 4 dumbbell test pieces shall only be used where insufficient material is available for the larger test pieces. These test pieces are particularly suitable for testing products and are used in certain product standards, e.g. type 3 dumbbells have been used for testing pipe sealing rings and cable coverings.

6.3 Rings

The standard type A ring test piece shall have an internal diameter of 44,6 mm ± 0,2 mm. The median axial thickness and median radial width shall be 4 mm ± 0,2 mm. The radial width of any ring shall nowhere deviate from the median by more than 0,2 mm and the axial thickness of the ring shall nowhere deviate from the median by more than 2 %.

The standard type B ring test piece shall have an internal diameter of 8 mm ± 0,1 mm. The median axial thickness and median radial width shall be 1 mm ± 0,1 mm. The radial width of any ring shall nowhere deviate from the median by more than 0,1 mm. This test piece shall be used only where insufficient material is available for the larger type A test piece.

7 Apparatus

7.1 Dies and cutters

All dies and cutters used shall be in accordance with ISO 23529. Dies for preparation of dumbbells shall have the dimensions given in [Table 2](#) and [Figure 3](#) except for the cutting edge for which [Figure 3](#) only indicates a suitable geometry. The departure from parallelism at any point along the width of the narrow portion of the die shall nowhere exceed 0,05 mm.

For a method of cutting type B ring test pieces, see [Annex A](#).

Table 2 — Dimensions of dies for dumbbell test pieces

Dimension mm	Type 1	Type 1A	Type 2	Type 3	Type 4
A Overall length (minimum) ^a	115	100	75	50	35
B Width of ends	25 ± 1	25 ± 1	12,5 ± 1	8,5 ± 0,5	6 ± 0,5
C Length of narrow portion	33 ± 2	21 ± 1	25 ± 1	16 ± 1	12 ± 0,5
D Width of narrow portion	6,2 ± 0,2	5 ± 0,1	4 ± 0,1	4 ± 0,1	2 ± 0,1
E Transition radius outside	14 ± 1	11 ± 1	8 ± 0,5	7,5 ± 0,5	3 ± 0,1
F Transition radius inside	25 ± 2	25 ± 2	12,5 ± 1	10 ± 0,5	3 ± 0,1

^a A greater overall length might be necessary to ensure that only the wide end tabs come into contact with the machine grips, thus avoiding “shoulder breaks”.

7.2 Thickness gauge

The instrument for measuring the thickness of dumbbell test pieces and the axial thickness of ring test pieces shall be in accordance with that used in method A of ISO 23529:2016.

The instrument for measuring the radial width of ring test pieces shall be similar to the above, except that the contact and base plate shall be shaped to fit the curvature of the ring.

7.3 Cone gauge

A calibrated cone gauge or other suitable equipment shall be used to measure the internal diameter of ring test pieces. The equipment shall be capable of measuring the diameter with an error of not more than 0,01 mm. The means of supporting the ring test piece to be measured shall be such as to avoid any significant change in the dimension being measured.