



Designation: **D5842–04 (Reapproved 2009) D5842 – 14**



Manual of Petroleum Measurement Standards (MPMS) Chapter 8.4

Standard Practice for Sampling and Handling of Fuels for Volatility Measurement¹

This standard is issued under the fixed designation D5842; the number immediately following the designation indicates the year of original adoption or, in the case of revision, the year of last revision. A number in parentheses indicates the year of last reapproval. A superscript epsilon (ϵ) indicates an editorial change since the last revision or reapproval.

1. Scope

1.1 This practice covers procedures and equipment for obtaining, mixing, and handling representative samples of volatile fuels for the purpose of testing for compliance with the standards set forth for volatility related measurements applicable to light fuels. The applicable dry vapor pressure equivalent range of this practice is 13 to 105 kPa (2 to 16 psia).

1.2 This practice is applicable to the sampling, mixing, and handling of reformulated fuels including those containing oxygenates.

1.3 The values stated in SI units are to be regarded as the standard except in some cases where drawings may show inch-pound measurements which are customary for that equipment.

1.4 *This standard does not purport to address all of the safety concerns, if any, associated with its use. It is the responsibility of the user of this standard to establish appropriate safety and health practices and determine the applicability of regulatory limitations prior to use.*

2. Referenced Documents

2.1 *ASTM Standards:*²

[D4057 Practice for Manual Sampling of Petroleum and Petroleum Products \(API MPMS Chapter 8.1\)](#)

[D4177 Practice for Automatic Sampling of Petroleum and Petroleum Products \(API MPMS Chapter 8.2\)](#)

[D5854 Practice for Mixing and Handling of Liquid Samples of Petroleum and Petroleum Products \(API MPMS Chapter 8.3\)](#)

[D7717 Practice for Preparing Volumetric Blends of Denatured Fuel Ethanol and Gasoline Blendstocks for Laboratory Analysis](#)

2.2 *API Standards:*³

[MPMS Chapter 8.1—Practice for Manual Sampling of Petroleum and Petroleum Products \(ASTM Practice D4057\)](#)

[MPMS Chapter 8.2—Practice for Automatic Sampling of Petroleum and Petroleum Products \(ASTM Practice D4177\)](#)

[MPMS Chapter 8.3—Practice for Mixing and Handling of Liquid Samples of Petroleum and Petroleum Products \(ASTM Practice D5854\)](#)

3. Terminology

3.1 *Definitions of Terms Specific to This Standard:*

3.1.1 *bottom sample—sample, n*—a sample obtained from the material at the bottom of the tank, container, or line at its lowest point.

¹ This practice is under the jurisdiction of ASTM Committee D02 on Petroleum Products—Products, Liquid Fuels, and Lubricants and the API Committee on Petroleum Measurement, and is the direct responsibility of Subcommittee D02.02.08 the joint ASTM-API Committee on Sampling (API MPMS Chapter 8.0).

Current edition approved July 1, 2009; Jan. 15, 2014. Published November 2009; January 2014. Originally approved in 1995. Last previous edition approved in 2004; 2009 as D5842–04, –04 (2009). DOI: 10.1520/D5842-04R09; 10.1520/D5842-14.

² For referenced ASTM standards, visit the ASTM website, www.astm.org, or contact ASTM Customer Service at service@astm.org. For *Annual Book of ASTM Standards* volume information, refer to the standard's Document Summary page on the ASTM website.

³ Available from American Petroleum Institute (API), 1220 L. St., NW, Washington, DC 20005-4070, http://www.api.org.

3.1.1.1 Discussion—

In practice the term bottom sample has a variety of meanings. As a result, it is recommended that the exact sampling location (for example, 15 cm [6 in.] from the bottom) should be specified when using this term.

3.1.2 *dead legs—legs, n*—sections of pipe that, by design, do not allow for the flow of material through them.

3.1.2.1 Discussion—

Dead legs are not suitable for obtaining representative samples.

3.1.3 relief lines—lines, n—sections of pipe that lead to a pressure/vacuum relief valve.

3.1.3.1 Discussion—

Relief lines are not suitable for obtaining representative samples.

3.1.4 ~~stand pipes~~—pipes, n—vertical sections of pipe or tubing extending from the gaging platform to near the bottom of tanks that are equipped with external or internal floating roofs. Stand pipes also may be found on ships and barges.

3.1.4.1 Discussion—

Stand pipes which are not slotted or perforated will not yield representative samples. Further information on proper stand pipe design is given in 6.4.3.

3.1.5 Other sample definitions are given in Practice D4057/API MPMS Chapter 8.1.

4. Summary of Practice

4.1 It is necessary that the samples be representative of the fuel in question. The basic principle of each sampling procedure involves obtaining a sample in such a manner and from such locations in the tank or other container that the sample will be representative of the fuel. A summary of the sampling procedures and their application is presented in Table 1. Each procedure is suitable for sampling a material under definite storage, transportation, or container conditions. The precautions required to ensure the representative character of the samples are numerous and depend upon the tank, carrier, container, or line from which the sample is being obtained, the type and cleanliness of the sample container, and the sampling procedure that is to be used.

5. Significance and Use

5.1 The dry vapor pressure equivalent (DVPE) of volatile motor fuels is regulated by federal and state air pollution control agencies. In order to meet the letter of these regulations, it is necessary to sample, handle, and test these products in a very precise manner: the precise manner as prescribed in this practice.

6. General Comments

6.1 Sample Containers:

6.1.1 Sample containers are clear or brown glass bottles, fluorinated high-density polyethylene bottles, or metal cans. The clear glass bottle is advantageous because it is easily examined visually for cleanliness, and also makes visual inspection of the sample for free water or solid impurities possible. The brown glass bottle affords some protection from light. The only cans acceptable are those with the seams soldered on the exterior surface.

6.1.2 Cork stoppers, or screw caps of plastic or metal, are used for glass bottles; screw caps with inserted seals only are used for cans to provide a vapor-tight closure seal. Corks must be of good quality, clean, and free from holes and loose bits of cork. Never use rubber stoppers. Contact of the sample with the cork can be prevented by wrapping tin or aluminum foil around the cork

TABLE 1 Summary of Gasoline Sampling Procedures and Applicability

Type of Container	Procedure	Paragraph
Storage tanks, ship and barge tanks, tank cars, tank trucks	all-levels sampling	7.2.1.2
	running sample	7.2.1.2
	upper, middle and lower samples	7.2.1.2
	top sample	7.2.1.2
Storage tanks with taps	grab sampling	7.5
	tap sampling	7.2.2
Pipes and lines	line sampling	7.3
	automatic sampling	7.4
	time proportional	7.4.1
	flow proportional	7.4.2
Retail outlet and wholesale purchaser-consumer facility storage tanks	grab sampling	7.5
	nozzle sampling	7.6

before forcing it into the bottle. Screw caps must be protected by a cork disk faced with tin or aluminum foil, an inverted cone polyseal or other material that will not affect petroleum or petroleum products. The fluorinated bottles are supplied with polypropylene screw caps.

6.1.3 Sample size is dictated by the test method to be used. One litre (32 oz) bottles or cans are generally used for manual vapor pressure testing. Some vapor pressure methods may allow a smaller sample size to be taken, such as in a 125 mL (4 oz) bottle. See Fig. 1.

6.1.4 All sample containers must be absolutely clean and free of foreign matter. Before reusing a container, wash it with strong soap solution, rinse it thoroughly with tap water, and finally with distilled water. Dry completely and stopper, or cap, the container immediately.

6.2 *Sampling Apparatus*—Sampling apparatus is described in detail under each of the specific sampling procedures. Clean, dry, and free all sampling apparatus from any substance that might contaminate the material. If necessary, use the clean procedure described in 6.4.

6.3 *Time and Place of Sampling* – *Sampling:*

6.3.1 *Storage Tanks*—When loading or discharging fuels, take samples from both shipping and receiving tanks, and from the pipelines if required.

6.3.2 *Ship or Barge Tanks*—Sample each product after the vessel is loaded or just before unloading.

6.3.3 *Tank Cars*—Sample the product after the car is loaded or just before unloading.

NOTE 1—Time, place, and other details of sampling not covered in this practice are normally determined by contractual agreement or regulatory requirements.

6.4 *Obtaining Samples:*

6.4.1 Directions for sampling cannot be made explicit enough to cover all cases. Extreme care and good judgment are necessary to ensure samples that represent the general character and average condition of the material. Use lint-free wiping cloths to prevent contaminating samples.

6.4.2 Many petroleum vapors are toxic and flammable. Avoid breathing them or igniting them from an open flame or a spark. Follow all safety precautions specific to the material being sampled.

6.4.3 Do not sample dead legs or relief lines. Do not sample stand pipes that are not slotted or perforated. Fig. 2 is an example of an adequately slotted stand pipe. At a minimum, the stand pipe should have two rows of slots slightly staggered in the vertical plane.

6.4.4 Rinse or flush sample containers with product and allow it to drain before drawing the sample. If the sample is to be transferred to another container (for testing other than DVPE), the sampling apparatus also is rinsed with some of the product and drained. When the sample is emptied into this container, upend the sampling apparatus into the opening of the sample container.

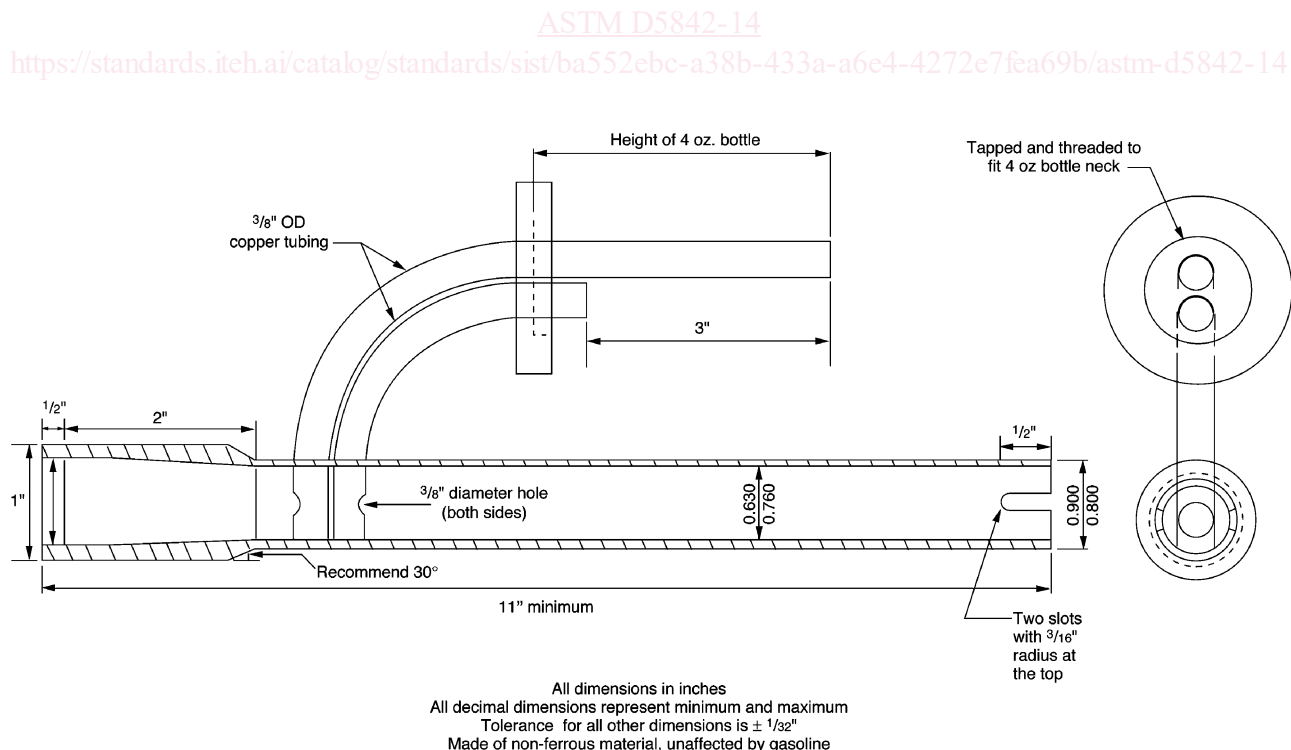

FIG. 1 Nozzle Extension for Nozzle Sampling with 4 oz Bottle

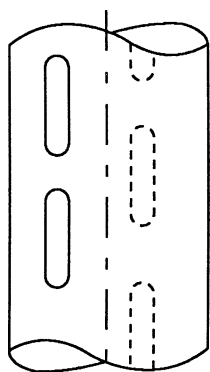

FIG. 2 Slotted Stand Pipe

6.5 Handling Samples:

6.5.1 Protect all samples of light fuels from evaporation. The sampling apparatus is the sample container for vapor pressure. Keep the container tightly closed after the sample is collected. Leaking sample containers are not suitable for testing. Cool volatile samples to 0 to 1°C (32 to 34°F) after delivery to the laboratory and before opening the container. Maintain at this temperature throughout transfer and handling, if at all possible.

6.5.2 Never completely fill a sample container. Fill the container to 70 to ~~80~~85 % capacity to allow adequate room for expansion. Subsequent testing for vapor pressure requires this level of container fill.

6.5.3 The first sample aliquot removed is for vapor pressure testing. The remaining sample in the container is not suitable for a vapor pressure determination but is suitable for other testing.

6.6 Shipping Samples—To prevent loss of liquid and vapors during shipment, place internal seals in the metal containers, screw the caps down tightly and check for leakage. Observe all shipping regulations applying to the transportation of flammable liquids.

6.7 Labeling Sample Containers—Label the container immediately after a sample is obtained. Use waterproof and oilproof ink or a pencil hard enough to dent the tag, since soft pencil and ordinary ink markings are subject to obliteration from moisture, product, smearing, and handling. Typical label information includes the following information:

- 6.7.1 Date and time (the period elapsed during continuous sampling),
- 6.7.2 Name of the sample (location),
- 6.7.3 Name or number and owner of the vessel, car, or container,
- 6.7.4 Brand and grade of material; and
- 6.7.5 Reference symbol or identification number.
- 6.7.6 Labeling should conform to all applicable federal, state, and local labeling regulations.

7. Specific Sampling Procedures

7.1 Sampling Procedures—The standard sampling procedures described in this practice are summarized in Table 1. Alternative sampling procedures can be used if a mutually satisfactory agreement has been reached by the party(ies) involved and such agreement has been put in writing and signed by authorized officials.

7.2 Tank Sampling:

7.2.1 Bottle Sampling—The bottle sampling procedure is applicable for sampling fuels of 105 kPa (16 psia) Reid equivalent vapor pressure or less in tank cars, tank trucks, shore tanks, ship tanks, and barge tanks.

7.2.1.1 Apparatus—A suitable sampling bottle as shown in Fig. 3 is required. Recommended diameter of the opening in the bottle or sample thief is 19 mm (¾ in.).

7.2.1.2 Procedure: (a) All-levels Sample—Lower the weighted, stoppered bottle (see Fig. 3) as near as possible to the draw-off level, pull out the stopper with a sharp jerk of the cord or chain and raise the bottle at a rate so that it is 70 to 85 % full as it emerges from the liquid.

(b) Running Sample—Lower the stoppered container (with a hole or slot in the stopper) at a uniform rate as near as possible to the level of the bottom of the outlet connection or swing line and immediately raise the bottle to the top of the fuel at a rate of speed such that it is 70 to 85 % full when withdrawn from the liquid.

NOTE 2—Running or all-level samples are not necessarily representative because the tank volume may not be proportional to the depth and because the operator may not be able to raise the sampler at the required rate.

(c) Upper, Middle, and Lower Samples—Lower the weighted, stoppered bottle to the proper depths (Fig. 4) as follows:

- | | |
|---------------|--|
| upper sample | middle of upper third of the tank contents |
| middle sample | middle of the tank contents |
| lower sample | middle of the lower third of the tank contents |