



Designation: **D7748/D7748M – 13** **D7748/D7748M – 14**

Standard Test Method for Flexural Rigidity of Geogrids, Geotextiles and Related Products¹

This standard is issued under the fixed designation D7748/D7748M; the number immediately following the designation indicates the year of original adoption or, in the case of revision, the year of last revision. A number in parentheses indicates the year of last reapproval. A superscript epsilon (ϵ) indicates an editorial change since the last revision or reapproval.

1. Scope

1.1 This test method covers the measurement of stiffness properties of geogrids, geotextiles and geogrid-geotextile composites all of which are referred to as geosynthetics within this test method. Bending length is measured and flexural rigidity is calculated through use of the cantilever test procedure.

1.1.1 This test method employs the principle of cantilever bending of the geosynthetic under its own mass.

1.2 This test method applies to geogrids, geotextiles and geogrid-geotextile composites.

1.3 This test method is for manufacturing quality control purposes only, to ensure uniformity and consistency of flexural rigidity for a specific product from roll to roll and lot to lot.

1.4 The values stated in either SI units or inch-pound units are to be regarded separately as standard. The values stated in each system may not be exact equivalents; therefore, each system shall be used independently of the other. Combining values from the two systems may result in non-conformance with the standard.

1.5 *This standard does not purport to address all of the safety concerns, if any, associated with its use. It is the responsibility of the user of this standard to establish appropriate safety and health practices and determine the applicability of regulatory limitations prior to use.*

2. Referenced Documents

2.1 *ASTM Standards:*²

[D123 Terminology Relating to Textiles](#)

[D1776 Practice for Conditioning and Testing Textiles](#)

[D4354 Practice for Sampling of Geosynthetics and Rolled Erosion Control Products\(RECPs\) for Testing](#)

[D4439 Terminology for Geosynthetics](#)

[E177 Practice for Use of the Terms Precision and Bias in ASTM Test Methods](#)

[E691 Practice for Conducting an Interlaboratory Study to Determine the Precision of a Test Method](#)

3. Terminology

3.1 For common definitions of terms in this test method, refer to Terminology [D123](#) and Terminology [D4439](#).

3.2 *Definitions of Terms Specific to This Standard:*

3.2.1 *bending length, n*—a measure of the interaction between geosynthetic weight and geosynthetic stiffness as shown by the way in which a geosynthetic bends under its own weight.

¹ This test method is under the jurisdiction of ASTM Committee [D35](#) on Geosynthetics and is the direct responsibility of Subcommittee [D35.01](#) on Mechanical Properties. Current edition approved ~~May 1, 2013~~ Jan. 1, 2014. Published ~~May 2013~~ January 2014. Originally approved in ~~2012~~ 2013 as ~~D7748–12~~ D7748/D7748M–13. DOI: ~~10.1520/D7748–13~~ 10.1520/D7748_D7748M–14.

² For referenced ASTM standards, visit the ASTM website, www.astm.org, or contact ASTM Customer Service at service@astm.org. For *Annual Book of ASTM Standards* volume information, refer to the standard's Document Summary page on the ASTM website.

3.2.1.1 *Discussion*—

Bending length reflects the stiffness of a geosynthetic when bent in one plane under the force of gravity.

4. Summary of Test Method

4.1 A specimen is slid at a specified rate in a direction parallel to its long dimension, until its leading edge projects from the edge of a horizontal surface. The length of the overhang is measured when the tip of the specimen is depressed under its own mass to the point where the line joining the top to the edge of the platform makes a 0.724 radians [41.5°] angle with the horizontal. From this measured length, the bending length and flexural rigidity are calculated.

5. Significance and Use

5.1 This test method is considered satisfactory for manufacturing quality control testing of a specific geosynthetic; however, caution is advised since information about between-laboratory precision is incomplete. Comparative tests as directed in 5.1.1 may be advisable.

5.1.1 In case of a dispute arising from differences in reported test results when using this test method for acceptance testing of commercial shipments, the purchaser and the supplier should conduct comparative tests to determine if there is a statistical bias between their laboratories. Competent statistical assistance is recommended for the investigation of bias. As a minimum, the two parties should take a group of test specimens that are as homogeneous as possible and that are from a lot of material of the type in question. Test specimens should then be randomly assigned in equal numbers to each laboratory for testing. The average results from the two laboratories should be compared using the appropriate statistical analysis and an acceptable probability level chosen by the two parties before testing is begun. If a bias is found, either its cause must be found and corrected or the purchaser and the supplier must agree to interpret future test results with consideration to the known bias.

5.2 This test method is not suitable for very limp geosynthetics or those that show a marked tendency to curl or twist at a cut edge.

5.3 The stiffness of a geosynthetic may change with storage.

5.4 No evidence has been found showing that bending length is dependent on specimen width. The tendency for specimens to curl or twist will affect the result, because of the rigidity provided at the edge. Consequently, the edge effect is less of an issue for a wider strip.

6. Apparatus

6.1 Flexural Rigidity Tester (Fig. 1).

6.1.1 *Horizontal Platform*, with a minimum area of 100 by 900 mm [4 by 36 in.] and having a smooth low-friction, flat aluminum surface. A leveling bubble shall be incorporated in the platform.

6.1.1.1 *Indicator*, inclined at an angle of 0.724 ± 0.01 radians [$41.5 \pm 0.5^\circ$] below the plane of the platform surface.

6.1.1.2 *Movable Slide*, consisting of a metal plate not less than 50 by 200 mm [2 by 8 in.] by approximately 3 mm [1/8 in.] thick and having a mass of 270 ± 5 g [0.6 ± 0.01 lb].

6.1.1.3 *Scale and Reference Point*, to measure the length of the overhang.

6.1.1.4 *Specimen Feed Unit*, motorized set to 120 mm/min [4.75 in./min] $\pm 5\%$, or manual equivalent.

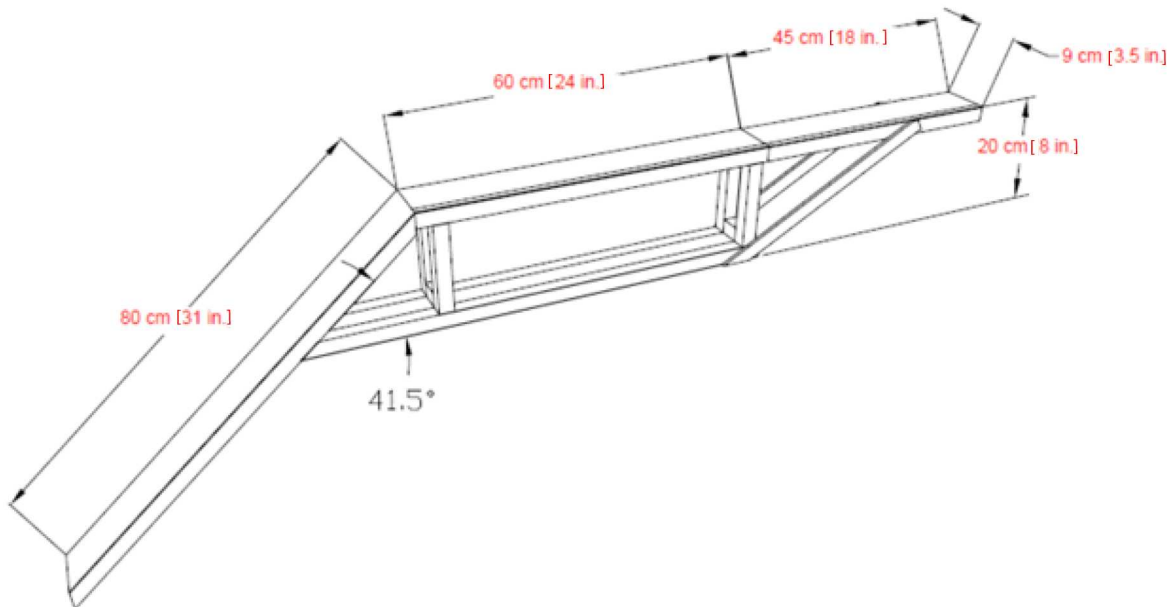

FIG. 1 Example Test Rig Setup



7. Sampling and Test Specimens

7.1 *Lot Sample*—As a lot sample for acceptance testing, randomly select the number of rolls or pieces of geosynthetic directed in an applicable material specification or other agreement between the purchaser and the supplier. Consider the rolls or pieces of geosynthetic to be the primary sampling units. In the absence of such an agreement, take the number of geosynthetic rolls specified in Practice [D4354](#).

7.2 For acceptance testing, take a swatch extending the width of the geosynthetic and approximately 2 m [6 ft] along the machine direction from each roll or piece in the lot sample. For rolls of geosynthetic, take a sample that will exclude geosynthetic from the outer wrap of the roll or the inner wrap around the core of the roll of geosynthetic, or any end piece.

7.3 *Direction of Test*—Consider the long dimension of the specimen as the direction of test.

7.4 *Number of Test Specimens*—From each laboratory sampling unit, take five specimens from the machine direction and five specimens from the cross-machine direction as applicable to a material specification or contract order.

7.5 *Cutting Test Specimens*—Cut the specimens to be used for the measurement of machine direction with the longer dimension parallel to the machine direction. Cut the specimens to be used for the measurement of the cross-machine direction with the longer dimension parallel to the cross-machine direction. Label to maintain specimen identity.

7.5.1 Take specimens, representing a broad distribution across the width and length, preferably along the diagonal of the laboratory sample, and no nearer the edge than one-tenth its width. Ensure specimens are free of folds, creases, or wrinkles. Avoid getting oil, water, grease, etc. on the specimens when handling.

7.5.2 For *geogrids* and *geotextile-geogrid composites* cut specimen such that the specimen include two (2) geogrid apertures in width or a minimum of 5 by 90 cm \pm 0.1 cm [minimum of 2 by 36 in. \pm 0.04 in.].

7.5.2.1 It is important to cut the ribs of the specimens in both the width and the length direction exactly midway between junctions such that a representative mass per unit area can be obtained for each specimen.

7.5.3 For *geotextiles* cut test specimens 5 by 90 cm \pm 0.1 cm [2 by 36 in. \pm 0.04 in.].

8. Preparation of Test Apparatus and Calibration

8.1 Set the tester on a table or bench with the horizontal platform and inclined reference lines. Adjust the platform to horizontal as indicated by the leveling bubble.

8.1.1 Verify that the apparatus bend angle is at the 0.724 radians [41.5°] angle.

9. Conditioning

9.1 For *Geogrids and Geogrid-geotextile Composites*—Do not fold or bend the lab sample. If the lab sample must be obtained from roll inventory, it shall be conditioned by counter rolling and taping the cut specimens in the opposite direction of the curl for a minimum of 24 h within a laboratory exhibiting the proper atmosphere for testing geosynthetics. Counter roll specimen to a diameter that is not more than that of the diameter from the original manufactured roll. For most products a diameter of 150 mm [6 in.] is adequate. Alternately, the sample can be conditioned by placing weights to restrain the specimen in a flat position for the 24-h period.

9.2 For *Geotextiles*—Precondition the specimens by bringing them to approximate moisture equilibrium in the standard atmosphere for preconditioning geotextiles as directed in Practice [D1776](#), unless otherwise directed in a material specification or contract order.

9.3 After preconditioning, bring the test specimens to equilibrium for testing in the standard atmosphere as, unless otherwise directed in a material specification or contract order, directed in Practice [D1776](#) or, if applicable, in the specified atmosphere in which the testing is to be performed.

10. Procedure

10.1 Test the conditioned specimens in the standard atmosphere for testing geosynthetics, which is $21 \pm 2^\circ\text{C}$ [$70 \pm 4^\circ\text{F}$] and 50 to ~~70%~~ 70 % relative humidity, unless otherwise directed in a material specification or contract order.

10.2 Remove the movable slide. Place the specimen on the horizontal platform with the length of the specimen parallel to the platform edge and the specimen face side up. Align the edge of the specimen with the line scribed on the right-hand edge of the horizontal platform.

10.2.1 Place the movable slide on the specimen, being careful not to change its initial position.

10.2.2 For automatic testers, turn the tester switch on and watch the leading edge of the specimen closely. Turn the switch off the instant the edge of the specimen touches the inclined portion of the tester.

10.2.3 For manual testers, move the clamped specimen by hand in a smooth manner at approximately 12 cm/min [4.75 in./min] \pm 5 % until the edge of the specimen touches the inclined portion of the tester, as shown in [Fig. 2](#) and [Fig. 3](#).

10.2.4 Read the overhang length by measuring the length still lying on the horizontal surface after the specimen has touched the inclined surface and subtracting that measurement from the initial specimen length. Record from the linear scale to the nearest 0.1 cm [0.1 in.].