



Standard Practice for Heat Fusion Joining of Polyethylene Pipe and Fittings¹

This standard is issued under the fixed designation F2620; the number immediately following the designation indicates the year of original adoption or, in the case of revision, the year of last revision. A number in parentheses indicates the year of last reappraisal. A superscript epsilon (ϵ) indicates an editorial change since the last revision or reappraisal.

1. Scope*

1.1 This practice describes procedures for making joints with polyethylene (PE) pipe and fittings by means of heat fusion joining in, but not limited to, a field environment. Other suitable heat fusion joining procedures are available from various sources including pipe and fitting manufacturers. This standard does not purport to address all possible heat fusion joining procedures, or to preclude the use of qualified procedures developed by other parties that have been proved to produce reliable heat fusion joints.

1.2 The parameters and procedures are applicable only to joining polyethylene pipe and fittings of related polymer chemistry. They are intended for PE fuel gas pipe per Specification **D2513** and PE potable water, sewer and industrial pipe manufactured per Specification **F714**, Specification **D3035**, and AWWA C901 and C906. Consult with the pipe manufacturers to make sure they approve this procedure for the pipe to be joined (see **Appendix X1**).

NOTE 1—Information about polyethylene pipe and fittings that have related polymer chemistry is presented in Plastics Pipe Institute (PPI) TR-33 and TR-41.

1.3 Parts that are within the dimensional tolerances given in present ASTM specifications are required to produce sound joints between polyethylene pipe and fittings when using the joining techniques described in this practice.

1.4 The values stated in inch-pound units are to be regarded as the standard. The values given in parentheses are for information only; mathematical conversions to SI units that are provided for information only and are not considered standard.

1.5 The text of this practice references notes, footnotes, and appendixes which provide explanatory material. These notes and footnotes (excluding those in tables and figures) shall not be considered as requirements of the practice.

1.6 *This standard does not purport to address all of the safety concerns, if any, associated with its use. It is the responsibility of the user of this standard to establish appropriate safety and health practices and determine the applicability of regulatory limitations prior to use.*

2. Referenced Documents

2.1 ASTM Standards:²

D2513 Specification for Polyethylene (PE) Gas Pressure Pipe, Tubing, and Fittings

D3035 Specification for Polyethylene (PE) Plastic Pipe (DR-PR) Based on Controlled Outside Diameter

F714 Specification for Polyethylene (PE) Plastic Pipe (DR-PR) Based on Outside Diameter

F1056 Specification for Socket Fusion Tools for Use in Socket Fusion Joining Polyethylene Pipe or Tubing and Fittings

2.2 PPI Documents:

TR-33 Generic Butt Fusion Joining Procedure for Field Joining of Polyethylene³

TR-41 Generic Saddle Fusion Joining Procedure for Polyethylene Gas Piping³

2.3 AWWA Documents:

AWWA C901 Standard for Polyethylene (PE) Pressure Pipe and Tubing, ½ in. (13 mm) through 3 in. (76 mm), for Water Service⁴

AWWA C906 Standard for Polyethylene (PE) Pressure Pipe and Fittings, 4 in. (100 mm) through 63 in. (1575 mm), for Water Distribution and Transmission⁴

¹ This practice is under the jurisdiction of ASTM Committee **F17** on Plastic Piping Systems and is the direct responsibility of Subcommittee **F17.20** on Joining. Current edition approved Aug. 1, 2012/Nov. 1, 2013. Published December 2012/January 2014. Originally approved in 2006. Last previous edition approved in 2011/2012 as **F2620–11/F2620–12**. DOI: 10.1520/F2620-12; 10.1520/F2620-13.

² For referenced ASTM standards, visit the ASTM website, www.astm.org, or contact ASTM Customer Service at service@astm.org. For *Annual Book of ASTM Standards* volume information, refer to the standard's Document Summary page on the ASTM website.

³ Available from Plastics Pipe Institute (PPI), 105 Decker Court, Suite 825, Irving, TX 75062, <http://www.plasticpipe.org>.

⁴ Available from American Water Works Association (AWWA), 6666 W. Quincy Ave., Denver, CO 80235, <http://www.awwa.org>.

*A Summary of Changes section appears at the end of this standard

3. Summary of Practice

3.1 The principle of heat fusion joining of polyethylene (PE) pipe is to heat two prepared surfaces to a designated temperature, then fuse them together by application of a sufficient force. This force causes the melted materials to flow and mix, thereby resulting in fusion.

3.2 The heat-fusion procedures covered in this practice are socket fusion, butt fusion, and saddle fusion.

3.2.1 *Procedure 1, Socket Fusion*—The socket-fusion procedure involves simultaneously heating the outside surface of a pipe end and the inside of a fitting socket, which is sized to be smaller than the smallest outside diameter of the pipe. After the proper melt has been generated at each face to be mated, the two components are joined by inserting one component into the other. See Fig. 1. The fusion bond is formed at the interface resulting from the interference fit. The melts from the two components flow together and fuse as the joint cools. Optional alignment devices are used to hold the pipe and socket fitting in longitudinal alignment during the joining process; especially with pipe sizes IPS 3 in. (89 mm) and larger. Automated socket fusion is not addressed in this procedure.

3.2.2 *Procedure 2, Butt Fusion*—The butt-fusion procedure in its simplest form consists of heating the squared ends of two pipes, a pipe and a fitting, or two fittings, by holding them against a heated plate, removing the heater plate when the proper melt is obtained, promptly bringing the ends together, and allowing the joint to cool while maintaining the appropriate applied force.

3.2.2.1 An appropriately sized butt fusion machine is used to clamp, align and face the pipe or fitting ends and to apply the specified fusion force. See Fig. 2.

3.2.3 *Procedure 3, Saddle Fusion*—The saddle-fusion procedure involves melting the concave surface of the base of a saddle fitting, while simultaneously melting a matching pattern on the surface of the pipe, bringing the two melted surfaces together and allowing the joint to cool while maintaining the appropriate applied force. See Fig. 3.

3.2.3.1 An appropriately sized saddle fusion machine is used to clamp the pipe main and the fitting, align the parts and apply the specified fusion force.

4. Significance and Use

4.1 The procedures described in Sections 7–9 are primarily intended for (but not limited to) field joining of polyethylene (PE) pipe and fittings, using suitable equipment and appropriate environmental control procedures. When properly implemented, strong pressure/leak-tight joints are produced. When these joints are destructively tested, the failure occurs outside the fusion joined area.

4.2 Melt characteristics, average molecular weight and molecular weight distribution are influential factors in establishing suitable fusion parameters; therefore, consider the manufacturer’s instructions in the use or development of a specific fusion procedure. See Annex A1.

4.3 The socket fusion, butt fusion, and saddle fusion procedures in this practice are suitable for joining PE gas pipe and fittings, PE water pipe and fittings, and PE general purpose pipes and fittings made to PE product specifications from organizations such

<https://standards.iteh.ai/catalog/standards/sist/4813c3c2-1375-44e5-a3dc-a456153942aa/astm-f2620-13>

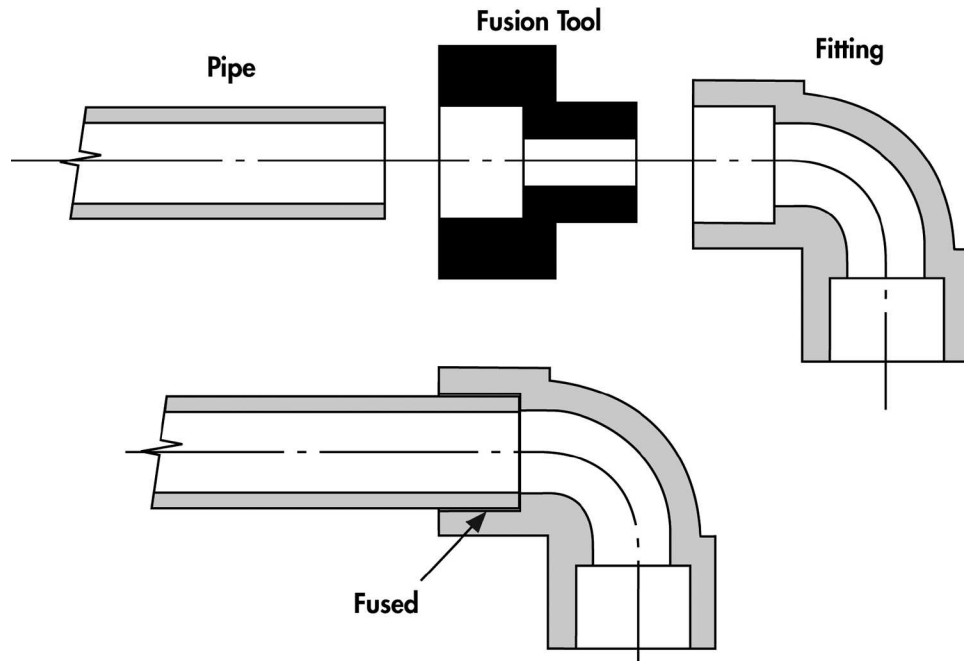

FIG. 1 Socket Fusion

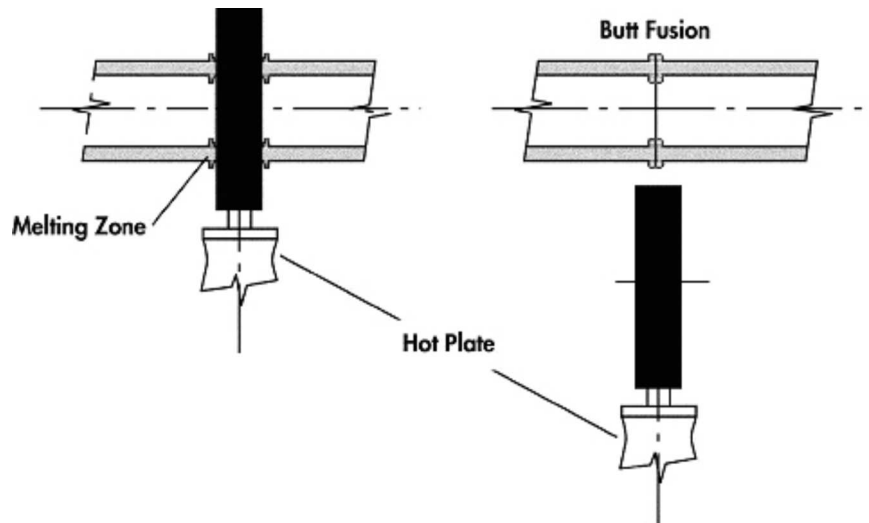

FIG. 2 Butt Fusion

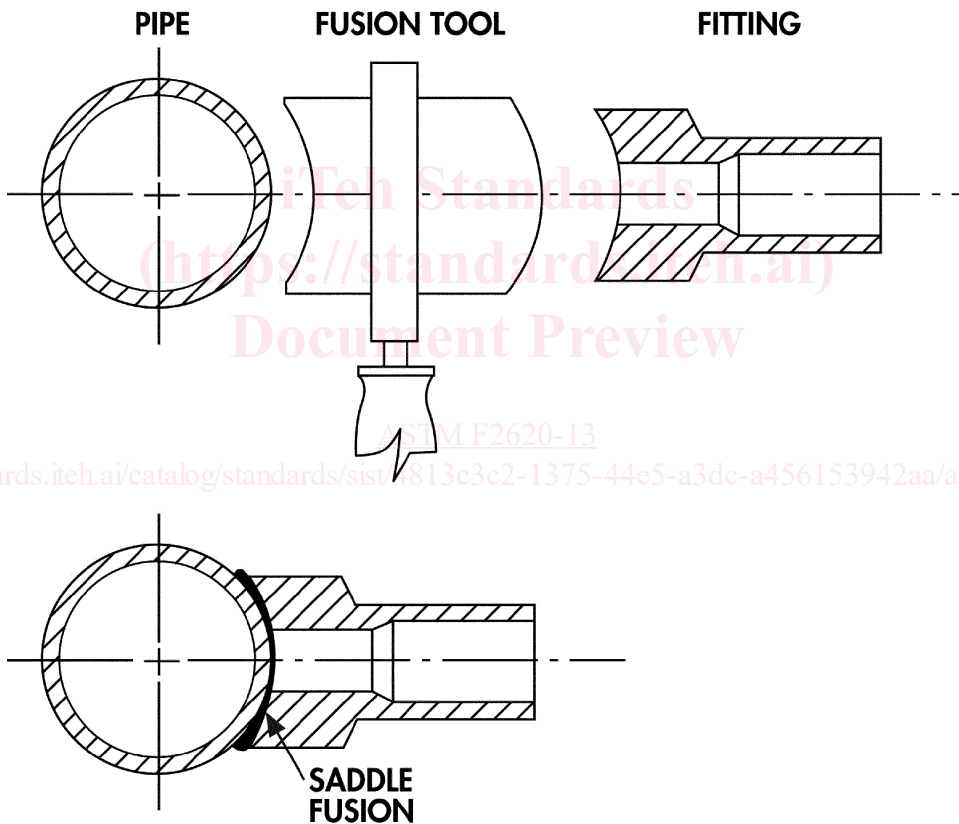

FIG. 3 Saddle Fusion

as ASTM, AWWA, API, and ISO that are used in pressure, low pressure and non-pressure applications. For gas applications, qualification of the procedure by testing joints made using the procedure in accordance with regulations from the authority having jurisdiction are required.

5. Operator Experience

5.1 Skill and knowledge on the part of the operator are required to obtain a good quality joint. This skill and knowledge is obtained by making joints in accordance with proven procedures under the guidance of skilled operators. Evaluate operator proficiency by testing sample joints.

5.2 The party responsible for the joining of polyethylene pipe and fittings shall ensure that detailed procedures developed in conjunction with applicable codes and regulations and the manufacturers of the pipe, fittings, and joining equipment involved, including the safety precautions to be followed, are issued before actual joining operations begin.

6. Apparatus—General Recommendations

6.1 *Heating Tool*—Electric heating tools come in a variety of sizes that match the fusion machines capabilities. They are designed with enough wattage and electronic control to maintain the specified heater face temperature required in this procedure. The range of the heater control shall be larger than the heating temperature specification (the typical control range is 50°F (30°C) above and below the maximum and minimum required heating tool surface temperatures. Electric heating plates maintain consistent fusion temperatures when provided with an adequate power source.

6.2 *Heating Tool Faces*—Heating tools may be made from materials such as aluminum, stainless steel, copper, or copper alloys. Polyethylene material may stick to hot metal heating surfaces. This sticking may be minimized by applying a non-stick coating to the heating surfaces or by fitting a high-temperature, non-stick fabric over the heating surfaces. The heating plate surfaces, coated or uncoated, shall be kept clean and free of contaminants such as dirt, grease and plastic build-up, which may cause excessive sticking and create unsatisfactory joints. Most of these contaminants are removed from the hot tool surfaces using a clean, dry, lint-free, non-synthetic cloth such as cotton. Do not use synthetic fabrics which may char and stick to the fusion surface. Some pigments, such as carbon black, may stain a heating surface and probably cannot be removed; such stains will not contaminate the joint interface.

6.2.1 After a period of time in service, non-stick coatings or fabrics will deteriorate and become less effective. Deteriorated fabrics shall be replaced, and worn, scratched, or gouged non-stick coatings shall be re-coated when they lose effectiveness. Heat fusion quality may be adversely affected by deteriorated non-stick surfaces. Spray-on chemicals, such as non-stick lubricants or oils shall not be applied to heating iron surfaces as they will contaminate the joint.

6.3 *Temperature Indicator*—Heating tools shall be equipped with a thermometer or other built-in temperature indicating device. This device indicates the internal temperature of the heating iron, which is usually higher than temperature of the heating tool surfaces. Use a pyrometer, or other temperature measuring device, on the first joint of the day and periodically during the day to verify the temperature of the tool face surfaces within the pipe or fitting contact area. Select multiple checkpoints to ensure uniform surface temperature. An infrared pyrometer is calibrated by comparison to a calibrated surface pyrometer and adjusted to agree on each heating tool.

NOTE 2—A significant temperature variation, that is, cold spots, on the heating tool surfaces may indicate a faulty heating iron which may need to be serviced before it can be used.

7. Procedure 1—Socket Fusion

7.1 Apparatus:

7.1.1 *Socket Fusion Tools*—Socket fusion tools consist of a heating tool, heating tool faces, rounding clamps (cold rings), depth gage/chamfer tools, and pipe/fittings made to ASTM specifications.

7.1.2 *Heating Tool*—In order to obtain a proper melt, it is necessary for a uniform temperature to be maintained across the heating tool faces. An electrical tool shall have sufficient wattage and control to maintain the specified surface temperature of the tool faces.

7.1.3 *Heating Tool Faces*—Consisting of two parts, a male end for the interior socket surface and a female end for the exterior pipe surface. Both parts shall be made to such tolerances as to cause an interference fit. Heating tool faces are produced to Specification **F1056** dimensions, and are coated with a non-stick material to keep melted pipe and fitting material from sticking to the face.

7.1.4 *Alignment Jig*—The alignment jig is an optional tool which consists of two sets of devices holding the components in alignment to each other. One set of holding devices is fixed, and the other allows longitudinal movement for making the joint.

7.1.5 *Rounding Clamps*, (cold ring) to maintain roundness of the pipe and control the depth of pipe insertion into the socket during the joining operation.

7.1.6 *Depth Gage*, for proper positioning of the rounding clamp on the pipe.

7.1.7 *Chamfering Tool*, to bevel the end of the pipe.

NOTE 3—The depth gage and chamfering tool may be combined into a single tool.

7.1.8 *Tubing Cutter*, to obtain a square end cut on the pipe.

7.1.9 *Fitting Puller*, an optional tool to assist in the removal of the fitting from the heating tool and to hold the fitting during assembly.

7.2 Procedure:

7.2.1 Attach the proper size heater faces to the heating tool, and bring the surface temperature of the tool faces to 490 to 510°F (254 to 266°C). Use a pyrometer, or other temperature measuring device, on the first joint of the day and periodically during the day to verify the temperature of the tool face surfaces within the pipe or fitting contact area. Select multiple checkpoints to ensure

uniform surface temperature. Heating tool thermometers measure the internal temperature of the heating tool, which is typically higher than the surface temperature of the heating tool faces.

7.2.2 Cut the pipe end squarely, and clean the pipe end and fitting, both inside and outside, by wiping with a clean, dry, lint-free, non-synthetic cloth such as cotton. If this does not remove the contamination, refer to **X1.7.1**.

7.2.3 Chamfer the outside edge of the pipe end slightly and fix the rounding clamp about the pipe as determined from the depth gage. (See **Note 4**.)

7.2.4 Clean the heater adapters by wiping them with a clean, dry, lint-free, non-synthetic cloth such as cotton to remove any contamination from the surfaces. Push the socket fitting onto the preheated fitting tool face first, and then push the pipe into the pipe-side tool face until the rounding clamps make contact with the heating faces.

7.2.5 Heat the pipe end and the fitting socket for the time required in **Table 1**.

7.2.6 At the end of the heating time, simultaneously remove the pipe and fitting straight out from the tool, using a snap action. Immediately insert the pipe straight into the socket of the fitting so the rounding clamp is flush against the end of the fitting socket. Hold or block the joint in place to cool for the time specified in **Table 1**. (For ambient temperatures 100°F and higher, additional cooling time may be needed.)

7.2.7 Remove the rounding clamp, and inspect the melt pattern at the end of the socket for a complete impression of the rounding clamp in the melt surface. There shall be no gaps, voids, or un-bonded areas. Visually inspect and compare the joint against recommended appearance guidelines (see **Appendix X2**). Allow the joint to cool an additional five (5) minutes before exposing the joint to any type of stresses (that is, burial, testing or fusing the other end of the fitting.)

7.2.8 Allow for extremes in weather when making field joints. Heating times, dimensional changes, etc., are affected by extreme weather conditions.

NOTE 4— Some recommend using a 50-60 grit emery or garnet cloth to roughen the outside of the pipe and inside of the fitting as a means of minimizing any possible skin interface when making the fusion. Sandpaper is not recommended for this purpose, as it might disintegrate and contaminate the joint interface. If roughening is performed, first clean the surfaces before roughening with a clean cloth or water. Once the pipe or fitting surfaces have been roughened and clean material has been exposed, water cannot be used to clean the pipe surfaces. Clean dust and particles from the roughened surfaces afterwards by cleaning the pipe or fitting ends with a clean dry lint-free, non-synthetic cloth such as cotton.

8. Procedure 2—Butt Fusion

8.1 Apparatus:

8.1.1 *Heating Tool*—The heating tool shall have sufficient area to adequately cover the ends of the size of pipe to be joined. This electrical tool shall have sufficient wattage and control to maintain the specified surface temperature of the tool faces. It shall also be equipped with heater faces that are coated with a non-stick material to prevent sticking to the pipe surface.

8.1.2 *Butt Fusion Machine*—A Butt Fusion Machine has three basic parts: (1) a stationary clamping fixture and a movable clamping fixture for aligning and holding each of the two parts to be fused. This may or may not include the power supply to operate the machine; (2) a facer for simultaneously preparing the ends of the parts to be joined (**Note 5**); and (3) appropriate inserts for clamping different pipe sizes or fitting shapes. Butt Fusion Machines are operated manually or hydraulically. Some have their own power supply and some require a separate generator. They are available in a variety of sizes to fuse pipe and tubing produced to ASTM and other industry specifications.

NOTE 5—A facer is a rotating cutting device used to square-off the pipe or fitting ends to obtain properly mating fusion surfaces. If so equipped, facing should continue until a positive mechanical stop on the butt fusion machine is reached.

8.1.3 *Pipe Support Stands*—Optional pipe support stands or racks are used to support the pipe at both ends of the butt fusion machine to assist with pipe loading and alignment.

8.2 Setup:

8.2.1 Butt fusion machine setup parameters are prescribed in **Table 2**.

TABLE 1 Socket Fusion Time Cycles

Pipe Size	PE 2406/ PE 2708		PE 3408/ PE 3608/ PE 4710	
	Heating Time Seconds	Cooling Time Seconds	Heating Time Seconds	Cooling Time Seconds
½ in CTS	6-7	30	6-10	30
¾ in CTS	6-7	30	6-10	30
1 in. CTS	9-10	30	9-16	30
1 ¼ in. CTS	10-12	30	10-16	30
½ in. IPS	6-7	30	6-10	30
¾ in. IPS	8-10	30	8-14	30
1 in. IPS	10-12	30	15-17	30
1¼ in. IPS	12-14	45	18-21	60
1½ in. IPS	14-17	45	20-23	60
2 in. IPS	16-19	45	24-28	60
3 in. IPS	20-24	60	28-32	75
4 in. IPS	24-29	60	32-37	75

TABLE 2 Butt Fusion Machine Setup Parameters

Setup Parameter		Required Condition
Manual Butt Fusion Machine	Hydraulic Butt Fusion Machine	
Set heating tool temperature and heat to specified temperature		The surface temperature of heating tool faces must be 400 to 450°F (204 to 232°C). (See X1.1.) A pyrometer or other surface temperature measuring device should be used periodically to insure proper surface temperature of the heating tool faces.
Install inserts	Install inserts	Install inserts for the pipe OD or the fitting being fused.
Electric power supply	Electric power supply	Check field generator for adequate power supply and fuel sufficient to complete the fusion joint.
Manual pressure	Set facing pressure	As required. Observe butt fusion machine manufacturer's instructions for setting facing pressure.
Manual pressure	Set heating pressure	Observe the pipe and butt fusion machine manufacturer's instructions for setting heating pressures.
Manual pressure (Drag a manual adjustment)	Set fusion joining pressure	Determine fusion joining pressure for the pipe OD and dimension ratio (DR) using 60 to 90 psi (414 to 621 kPa) interface pressure. Observe pipe and butt fusion machine manufacturer's instructions to determine the theoretical fusion joining pressure. Drag pressure is the amount of pressure required to get the carriage to move. Add this pressure to the theoretical fusion joining pressure to get the actual machine gage pressure to set.
Manual pressure	Set fusion joining pressure	Determine fusion joining pressure for the pipe OD and dimension ratio (DR) using 60 to 90 psi (414 to 621 kPa) interface pressure. Observe pipe and butt fusion machine manufacturer's instructions to determine the theoretical fusion joining pressure.
	Determine drag pressure	Drag pressure is the amount of pressure required to get the carriage to move. Add this pressure to the theoretical fusion joining pressure to get the actual machine gage pressure to set.

8.2.2 An interfacial pressure (IFP) of 60 to 90 psi (0.41 to 0.62 MPa) is used to determine the force required to butt fuse the pipe components. Multiply the interfacial pressure times the pipe area to calculate the fusion force required (F_b). For manually operated fusion machines, enough force should be applied to roll the bead back to the pipe surface. A torque wrench may be used to apply the proper force. Manual fusion without a torque wrench has been used successfully by many gas utilities. For hydraulically operated fusion machines, the IFP is multiplied by the pipe area (A_p) fusion force is—) to obtain the fusion force required in pounds. The fusion force required is then divided by the total effective piston area (TEPA) of the movable fusion machine carriage cylinders to give obtain the theoretical butt fusion pressure in psig. (TFP) (See Eq 2 The internal and external drag factors are). The drag pressure (P_D) is then added to this figure the TFP to obtain the actual fusion machine gage pressure (P_G) in psig required by the machine. (The theoretical machine, see (Eq 1 butt fusion pressure and the interfacial pressure-). (TFP and IFP are not the same value.) This P_D drag pressure is found by bringing the faced pipe ends within 2 in. (50 mm) of each other and increase the pressure on the carriage until it starts moving. Back off the pressure until the carriage is barely moving and record the drag pressure in psig. Add this pressure to the theoretical butt fusion pressure to obtain the fusion machine gage pressure. The equations used to calculate for the fusion machine gage pressure is shown below. These equations only apply when using a hydraulic fusion machine.

$$P_G = TFP + P_D \quad (1)$$

$$TFP = (A_p \times IFP) / TEPA \quad (2)$$

$$A_p = (OD - t) \times t \times 3.1416 \quad (3)$$

psig

where:

- P_G ≡ Fusion Machine Gauge Pressure, psig
- TFP ≡ Theoretical Fusion Pressure, psig
- IFP ≡ Interfacial Pressure, 60 – 90 psig
- $TEPA$ ≡ Total Effective Piston Area, in² – Supplied by fusion machine manufacturer
- P_D ≡ Fusion Machine Drag Pressure, psig
- A_p ≡ Pipe Area, in²
- OD ≡ Pipe Outside Diameter, in
- t ≡ Pipe Wall Thickness, in

required for fusion:

NOTE 6—Interfacial pressure is used to determine butt fusion joining pressure settings for hydraulic butt fusion machines when joining specific pipe diameters and DR's. Interfacial pressure is *not* the gauge pressure. A slide rule or a gauge pressure calculator obtained from the machine's manufacturer can be used as a tool for the calculation.

8.3 Procedure:

8.3.1 Clean the inside and outside of the components (pipe or pipe and fitting) to be joined with a clean, dry, lint-free, non-synthetic cloth such as cotton. Remove all foreign matter from the piping component surfaces where they will be clamped in the butt fusion machine. If this does not remove the contamination, refer to [X1.7.1](#).

8.3.2 If applicable, place pipe support stands at both ends of the butt fusion machine and adjust the support stands to align the pipe with the fusion machine centerline. Install the pipes or fittings being joined in the stationary and movable clamps of the butt fusion machine. Leave enough pipe protruding through the clamps to allow for facing and clamp the pipe or fitting in the machine.

8.3.2.1 Take care when placing pipe or fittings in the butt fusion machine. Pipes shall be aligned before the alignment clamp is closed. Do not force the pipe into alignment by pushing it against the side of an open butt fusion machine clamp. Pipes that are freshly cut and molded fittings generally do not have toe-in, and when mated to old-cut pipe or fabricated fittings, removing toe-in can ease adjustment for high-low alignment.

8.3.3 Face the piping component ends until the facer bottoms out on the stops and is locked between the jaws to establish clean, parallel mating surfaces between the pipe/fitting ends (see [Note 5](#)). Move the carriage to separate the pipe ends from the facer, remove the facer and all shavings and debris from the facing operation by brushing away with a clean, dry, lint-free, non-synthetic cloth such as cotton. Bring the pipe/fitting ends together at facing pressure. A visual inspection of this operation should verify a square face, perpendicular to the pipe centerline on each pipe end and with no detectable gap.

8.3.4 Check the pipe ends for high-low alignment and out-of-roundness. If adjustment is needed, adjust the high side down by tightening the high side clamp. Do not loosen the low side clamp or slippage may occur during fusion. Re-face the pipe or fitting ends if excessive adjustment is required (more than 180° rotation of the clamp knob) and remove any shavings from the re-facing operation with a clean, dry, lint-free, non-synthetic cloth such as cotton. The maximum OD high-low misalignment allowed in the butt fusion procedure is to be less than 10 % of the pipe minimum wall thickness.

8.3.5 Verify that the heater surface temperatures are in the specified temperature range 400 to 450°F (204 to 232°C). (See [Appendix X1](#).) A pyrometer or other surface temperature measuring device should be used before the first joint of the day and periodically throughout the day to insure proper temperature of the heating tool face. All pyrometers are sensitive to usage techniques. Carefully follow the manufacturer's instructions for best results.

8.3.5.1 Clean the contact surfaces of the heating tool with a clean, dry, lint-free, non-synthetic cloth such as cotton. Place the heating tool in the butt fusion machine between the piping component ends and bring the pipe or fitting ends into full contact with the heating tool at fusion pressure. Briefly ensure full contact between piping component ends and the heating tool and then reduce the pressure to drag pressure but without breaking contact between the piping component ends and the heating tool. (On larger pipe sizes, (14 in. and larger) hold fusion pressure until a slight melt is observed around the circumference of the pipe or fitting before reducing pressure. This normally varies from about 10 s on 14 in. pipe to greater than 2 min on 36 and larger pipe sizes.)

8.3.5.2 Once the indication of melt is observed around the circumference of the pipe, begin the heat soak by reducing the pressure to maintain contact, without force, while a bead of molten polyethylene develops between the heater and the pipe or fitting ends. For 14 in. IPS pipe sizes and larger, maintain the heat soak for a minimum of 4.5 minutes for every inch (25.4 mm) of pipe wall thickness. (example: minimum heat soak time for a pipe with .50 in. (12.7mm) wall would be 2 min 15 s). Continue heating the pipe ends until the melt bead size has developed against the heater face per [Table 3](#).

8.3.6 When the proper bead size is observed, quickly move the piping component ends away from the heating tool, remove the heating tool and quickly inspect the pipe ends.

8.3.6.1 Acceptable melt appears flat and smooth with no unmelted areas. Unacceptable melt appearance is any combination of a concave surface, unmelted areas, a bubbly pock-marked sandpaper-like surface or melted material sticking to heating tool surfaces (see [Fig. X2.7](#)). Low strength joints result from unacceptable melt appearance. Discontinue the joining procedure, allow the component ends to cool completely and restart from [8.3.1](#). (See [Appendix X2](#).)

8.3.6.2 The maximum time allowed for opening the machine, removing the heater and bringing the pipe ends together is shown in [Table 4](#). For tubing sizes that are generally butt fused with mechanical fusion machines (not hydraulically controlled) (½ CTS to 1 ½ in. IPS), the maximum open/close time is 4 s. The quicker you can safely do this process, the better. See [A1.4.3.1](#) for guidance on butt fusion in cold temperatures. Do not slam the pipe ends together.

NOTE 7—A concave melt surface is caused by unacceptable pressure during heating.

8.3.6.3 The correct fusion pressure rolls both melt beads over so that they touch the piping component OD surfaces. Do not use excessive or insufficient force (more than or less than the fusion interfacial pressure range). If the components are brought together with excessive force, molten material may be pushed out of the joint and cold material brought into contact forming a “cold” joint. If too little force is used, voids and weak bonded areas can develop in the joint as molten material cools and contracts.

8.3.7 Hold the molten joint immobile under fusion pressure until sufficiently cooled. Cooling under pressure before removal from the butt fusion machine is important in achieving joint integrity. Maintain fusion pressure against the piping component ends for a minimum of 11 minutes per inch (25.4 mm) of pipe wall. For ambient temperatures 100°F and higher, additional cooling time may be needed. Avoid high stress such as pulling, installation or rough handling for an additional 30 min or more after removal from the fusion machine (only 10 minutes additional cooling time is required for IPS 1 in. and smaller pipe sizes). Do not apply internal pressure until the joint and surrounding material have reached ambient air temperature. (See [Appendix X1](#).)

NOTE 8—Pouring water or applying wet cloths to the joint to reduce cooling time is not acceptable. Applying conditioned air is acceptable only as part

TABLE 3 Minimum Melt Bead Size

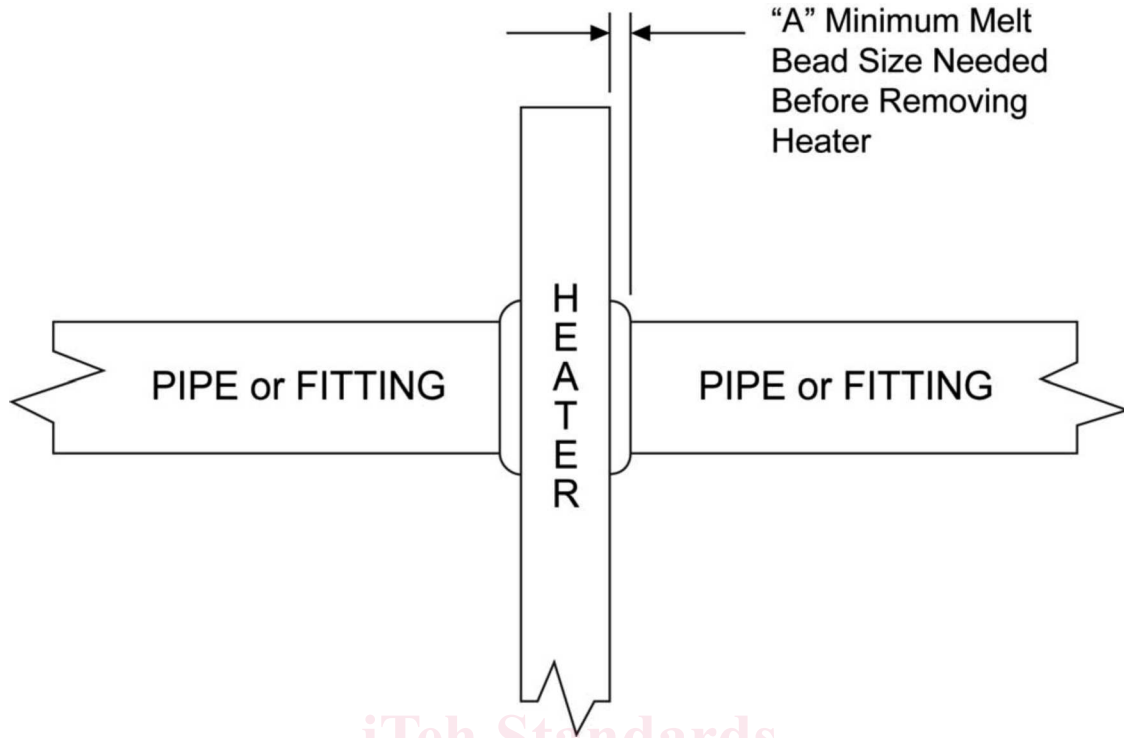

Pipe (OD) [Outside Diameter, in. (mm)]	"A" Minimum Bead Size, in. (mm)
< 2.37 (60)	1/32 (1)
≥ 2.37 (60) ≤ 3.5 (89)	1/16 (1.5)
> 3.5 (89) ≤ 8.62 (219)	3/16 (5)
> 8.62 (219) ≤ 12.75 (324)	1/4 (6)
> 12.75 (324) ≤ 24 (610)	3/8 (10)
> 24 (610) ≤ 36 (900)	7/16 (11)
> 36 (900) ≤ 65 (1625)	9/16 (14)

ASTM F2620-13

TABLE 4 Maximum Heater Plate Removal Times

NOTE 1—Fusion joints made in an enclosed and controlled factory fabrication environment will tolerate and may use longer maximum heater removal times.

Field Applications Pipe Wall Thickness, in. (mm)	Max. Heater Plate Removal Time Seconds
0.17 to 0.36 (5 to 9)	8
>0.36 to 0.55 (9 to 14)	10
>0.55 to 1.18 (14 to 30)	15
>1.18 to 2.5 (30 to 64)	20
>2.5 to 4.5 (64 to 114)	25

of a controlled cooling cycle procedure where testing demonstrates that acceptable joints are produced using the controlled cooling cycle procedure.

8.3.7.1 Visually inspect and compare the joint against the butt fusion bead visual inspection acceptance guideline in Fig. 4. The v-groove between the beads should not be deeper than half the bead height above the pipe surface. When butt fusing to molded fittings, the fitting-side bead may display shape irregularities such as minor indentations, deflections and non-uniform bead rollover from molded part cooling and knit lines. In such cases, visual evaluation is based mainly on the size and shape of the pipe-side bead. (See Appendix X2 for additional guidance.)

9. Procedure 3—Saddle Fusion

9.1 Apparatus:

9.1.1 Heating Tool and Faces—This electrical tool shall have sufficient wattage and control to maintain the specified surface temperature of the tool faces. The serrated or smooth faces are matched sets, by pipe size, of concave and convex blocks, which bolt or clamp onto a flat heating tool. The heating faces are coated with a non-stick material to prevent sticking to the pipe or fitting surfaces.

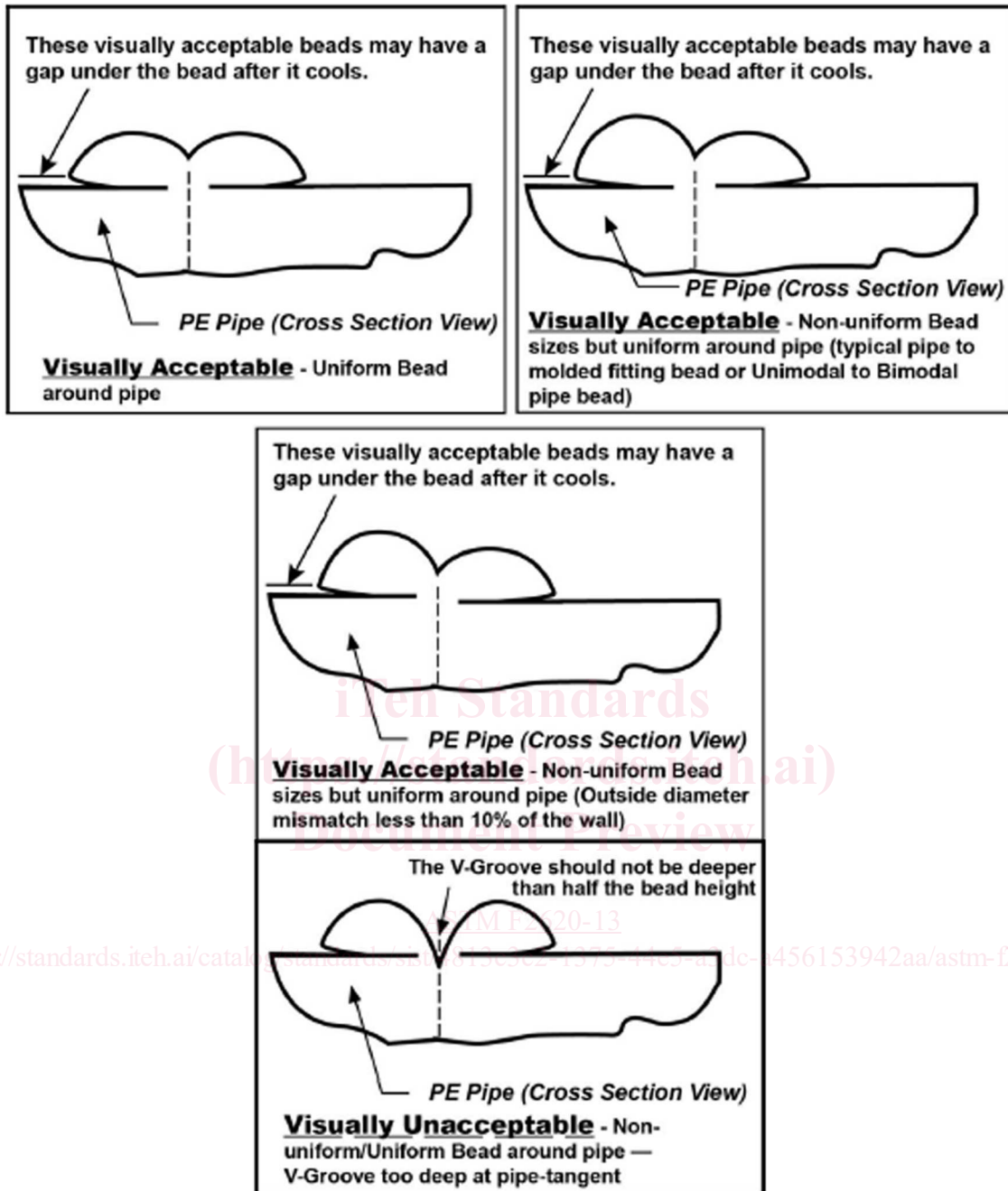

FIG. 4 Outside Diameter Butt Fusion Bead Guideline

9.1.2 *Saddle Fusion Tool*—This tool clamps to the main, rounding and supporting the main for good alignment between the pipe and fitting. It holds the fitting, in correct alignment to the main. It also applies and indicates the proper force during the fusion process. A support or bolster is clamped to IPS 6 in. (168 mm) and smaller main pipe opposite the fitting installation area to support the main and assist in rounding the pipe.

9.1.3 *Optional Flexible Heat Shield*—A flexible heat resistant metal or insulated fabric pad used to help establish a melt pattern on larger mains before applying heat to the fitting.

9.2 *Saddle Fusion Terminology:*

9.2.1 *Initial Heat (Bead-up)*—The heating step used to develop an initial melt bead on the main pipe.

9.2.2 *Initial Heat Force (Bead-up Force)*—The force (lb) applied to establish an initial melt pattern on the main pipe. The Initial Heat Force is determined by multiplying the fitting base area (in.²) by the initial interfacial pressure 60 (lb/in.²).

9.2.3 *Heat Soak Force*—The force (lb) applied after an initial melt pattern is established on the main pipe. The Heat Soak Force is the minimum force (essentially zero pounds) that ensures that the fitting, heater and main stay in contact with each other.

9.2.4 *Fusion Force*—The force (lb) applied to establish the fusion bond between the fitting and the pipe. The fusion Force is determined by multiplying the fitting projected base area (in.²) by the fusion interfacial pressure 30 (lb/in.²).

9.2.5 *Total Heat Time*—A time that starts when the heater is placed on the main pipe and initial heat force is applied and ends when the heater is removed.

9.2.6 *Cool Time*—The time required to cool the joint to approximately 120°F (49°C). The fusion force must be maintained for 5 min on IPS 1¼ in. (42 mm) or 10 min for all other main sizes, after which the saddle fusion equipment can be removed. The joint must be allowed to cool undisturbed for an additional 30 min before tapping the main or joining to the branch saddle.

9.2.7 *Interfacial Area for Rectangular Base Fittings*—The major width times the major length of the saddle base, without taking into account the curvature of the base or sides, minus the area of the hole in the center of the base.

9.2.8 *Interfacial Area for Round Base Fittings*—The radius of the saddle base squared times π (3.1416) without taking into account the curvature of the base or sides, minus the area of the hole in the center of the base.

9.2.9 *Fitting Label*—The initial heat force, heat soak force and the fusion force will be listed on a fitting label in the lower right hand corner of the fitting for some manufacturer’s saddle fusion fittings. This will eliminate the need to calculate the fusion forces in the field (for example, 180/0/90). If the label is not present, the heat and fusion forces need to be calculated.

9.3 Setup:

9.3.1 Select and install the proper heating tool faces to the heating tool based on the main size and fitting base size. Consult the pipe, fitting or equipment manufacturer’s recommendations.

9.3.2 Plug in the heating tool and bring the heating tool face surfaces to 490 to 510°F (254 to 266°C) (see **Table 5**). A pyrometer or other surface temperature measuring device is used to determine and periodically check the heating tool surface temperature. Heating tool thermometers measure the internal temperature of the heating tool which is typically higher than the surface temperature of the heating tool faces.

9.3.3 Install the proper clamps in the Saddle Fusion Tool for the main size to be fused. Install the proper fitting clamp for the fitting to be joined. Consult the pipe, fitting or equipment manufacturer’s recommendations.

9.4 Procedure:

9.4.1 Preparation:

9.4.1.1 Clean the inside and outside of the components (pipe or pipe and fitting) to be joined with a clean, dry, lint-free, non-synthetic cloth such as cotton. Remove all foreign matter from the piping component surfaces where they will be clamped in the butt fusion machine. If this does not remove the contamination, refer to **X1.7.1**. Install the Saddle Fusion Tool on the main according to the manufacturer’s instructions. The tool should be centered over a clean, dry location where the fitting will be fused. Secure the tool to the main. A main bolster or support is recommended under the pipe on IPS 6 in. (168 mm) and smaller main pipe sizes.

9.4.1.2 Abrade or scrape the surface of the main, where the fitting will be joined, approximately 0.007 in. (.178mm) deep to remove any oxidation or contamination. This can be done before or after the Tool is attached to the main. The abraded/scraped area must be larger than the area covered by the fitting base. It is important that the pipe surface be free from any type of contaminants that may be spread before the scraping or abrading process begins. Marks can be made on the outer surface of the pipe to aid in visual indication of abrading/scraping coverage, however the marks should be made with a non-petroleum based fast drying marker. After abrading/scraping, clean the pipe or fitting ends with a clean, dry, lint-free, non-synthetic cloth such as cotton. All markings on the pipe surface should be removed before beginning the heat cycle.

9.4.1.3 Abrade the fusion surface of the fitting with 50 to 60 grit utility cloth; remove all dust and residue with a clean, dry, lint-free, non-synthetic cloth such as cotton. Insert the fitting in the Saddle Fusion Tool loosely. Using the Saddle Fusion Tool, move the fitting base against the main pipe and apply about 100 lbf to seat the fitting. Secure the fitting in the Saddle Fusion Tool.

9.4.2 Heating Procedure for Small Fittings (<2 in. IPS) (see **Table 5**):

9.4.2.1 Clean the heating tool faces with a clean, dry, lint-free, non-synthetic cloth such as cotton. Place the heating tool on the main centered beneath the fitting base. Immediately move the fitting against the heater faces, apply the Initial Heat Force (see

TABLE 5 Generic Saddle Fusion Parameters

Heater Adapter Surface Temperature	500 ± 10°F (260 ± 6°C)
Initial Interfacial Pressure	60 ± 6 psi (4.14 ± 0.41 bar)
Heat Soak Interfacial Pressure	0 psi
Fusion Interfacial Pressure	30 ± 3 psi (2.07 ± 0.20 bar)
Total Heating Time on Main—1¼ in. IPS Pressure Main	15 s max
Total Heating Time on Main—2 in. IPS Pressure Main	25 to 35 s max
Total Heating Time on non-pressure 1¼ in. IPS, 2 in. IPS mains, and on pressure or non-pressure 3 in. IPS and larger mains.	Look for a ¼ in. (1.6 mm) bead around the fitting base