



Designation: E990 – 13

Standard Specification for Core-Splice Adhesive for Honeycomb Sandwich Structural Panels¹

This standard is issued under the fixed designation E990; the number immediately following the designation indicates the year of original adoption or, in the case of revision, the year of last revision. A number in parentheses indicates the year of last reapproval. A superscript epsilon (ϵ) indicates an editorial change since the last revision or reapproval.

This standard has been approved for use by agencies of the U.S. Department of Defense.

1. Scope

1.1 This specification covers core-splice adhesive for use with nonmetallic honeycomb cores in the fabrication of honeycomb sandwich panels used in relocatable structures. The adhesive shall be used for new production or depot repair. The adhesive shall be suitable for forming bonds that can withstand long combinations of stress, temperature, and relative humidity expected to be encountered in service. The adhesive shall be used for bonding core segments and for bonding core segments to edge members and to integral members in a honeycomb sandwich panel. The adhesive shall not allow the transfer of water from one part of the panel to another either through or along the line of the adhesive.

1.2 The values stated in SI units are to be regarded as the standard. The values given in parentheses are for information only.

1.3 The following precautionary caveat pertains only to the test method portion, Section 6, of this specification: *This standard does not purport to address all of the safety concerns, if any, associated with its use. It is the responsibility of the user of this standard to establish appropriate safety and health practices and determine the applicability of regulatory limitations prior to use.*

2. Referenced Documents

2.1 ASTM Standards:²

B209 Specification for Aluminum and Aluminum-Alloy Sheet and Plate

C393/C393M Test Method for Core Shear Properties of Sandwich Constructions by Beam Flexure

¹ This specification is under the jurisdiction of ASTM Committee E06 on Performance of Buildings and is the direct responsibility of Subcommittee E06.53 on Materials and Processes for Durable Rigidwall Relocatable Structures.

Current edition approved Oct. 1, 2013. Published February 2014. Originally approved in 1984. Last previous edition approved in 2009 as E990–09. DOI: 10.1520/E0990-13.

² For referenced ASTM standards, visit the ASTM website, www.astm.org, or contact ASTM Customer Service at service@astm.org. For *Annual Book of ASTM Standards* volume information, refer to the standard's Document Summary page on the ASTM website.

D792 Test Methods for Density and Specific Gravity (Relative Density) of Plastics by Displacement

E631 Terminology of Building Constructions

E864 Practice for Surface Preparation of Aluminum Alloys to Be Adhesively Bonded in Honeycomb Shelter Panels

E865 Specification for Structural Film Adhesives for Honeycomb Sandwich Panels

E874 Practice for Adhesive Bonding of Aluminum Facings to Nonmetallic Honeycomb Core for Shelter Panels

E1091 Specification for Nonmetallic Honeycomb Core for Use in Shelter Panels

E1749 Terminology Relating to Rigid Wall Relocatable Shelters

2.2 Federal Standards:³

QQ-A-250/4 Aluminum Alloy 2024, Plate and Sheet

QQ-A-250/8d Aluminum Alloy 5052H34, Plate and Sheet

QQ-A-250/11d Aluminum Alloy 6061T6, Plate and Sheet

2.3 Military Standards:³

MIL-S-8802 Sealing Compound, Temperature-Resistant, Integral Fuel Tanks, and Fuel Cell Cavities, High-Adhesion

3. Terminology

3.1 *Definitions*—See Terminologies E631 and E1749 for definitions of general terms used in this specification.

4. Materials and Manufacture

4.1 The adhesive shall be free of foreign materials, be noncorrosive to the metal parts, and have the structural integrity equal to or better than that of an unspliced panel section as specified in Table 1, Flexural Shear.

5. Requirements

5.1 *Material*—The adhesive shall be thermosetting and when tested in accordance with Section 6, shall meet the requirements of Table 1. The adhesive shall not have a deleterious effect on the panel nor on its component parts over the range of temperature at which the adhesive will be used.

³ Available from DLA Document Services, Building 4/D, 700 Robbins Avenue, Philadelphia, PA 19111-5094, http://quicksearch.dla.mil/.

TABLE 1 Physical Properties Qualification Requirements

Table	Reference Paragraph	Requirements
Water migration	6.1	Not more than the volume of the cavity (in cell)
Volatility	6.2	1 % maximum
Expansion	6.3	1.75 minimum ratio
Sag for 1.27 mm (0.05 in.) uncured thickness	6.4	3.8 mm (0.15 in.) maximum
Sag for 2.54 mm (0.1 in.) uncured thickness	6.4	12.7 mm (0.500 in.) maximum
Density (cured)	6.5	0.8 g per cm ³ (50 lb/ft ³) maximum
Flexural shear (assembly compatibility)	6.6	Same as honeycomb core, minimum 1.24 MPa (180 psi) L-direction
Tube shear (core splice integrity)	6.7	Minimum average 4.13 MPa (600 psi) Minimum individual 3.1 MPa (450 psi)

This adhesive shall be compatible and capable of co-curing with the structural film adhesive (Specification E865) used to fabricate the panel.

5.2 *Form*—The adhesive shall be of film form either 1.27 mm (0.051 in.) or 2.54 mm (0.100 in.) thick and shall be capable of expanding to at least 1.75 times its original thickness.

5.3 *Working Characteristics:*

5.3.1 *Application*—The adhesive shall be suitable for application to core material, edge members, and integral parts in accordance with the manufacturer’s instructions at temperatures from 18 to 30°C (65 to 85°F) and at relative humidities of up to 50 %.

5.3.2 *Curing*—The time, temperature, and pressure used to cure the adhesive shall be as specified herein.

5.3.2.1 *Curing Time and Temperature*—The adhesive shall meet the requirements of this specification when cured in accordance with manufacturer’s recommendation so long as the time and bondline temperature do not exceed 1 h or 145°C (293°F).

5.3.2.2 *Curing Pressure*—The pressure required for curing the adhesive shall be contact.

5.4 *Storage Life*—The adhesive shall have a minimum storage life of 3 months from the date of receipt at the fabricator facility when stored at –17.8°C (0°F) or below. Under conditions in accordance with 5.3.1, the adhesive shall have a cumulative out-life of at least 5 days at 24 ± 3°C (75 ± 5°F).

5.5 *Properties*—The properties of the test specimens prepared and tested as described herein shall conform to the requirements of Table 1.

6. Test Methods

6.1 *Water Migration Test:*

6.1.1 The core Splice Adhesive Mold is illustrated in Fig. 1 (Note 1). Apply a mold release agent to both the interior of the female portion and the exterior of the male portion of the mold. Install a layer of adhesive (Note 2) on the entire length of the 19.05 mm diameter part of the male portion of the mold so that

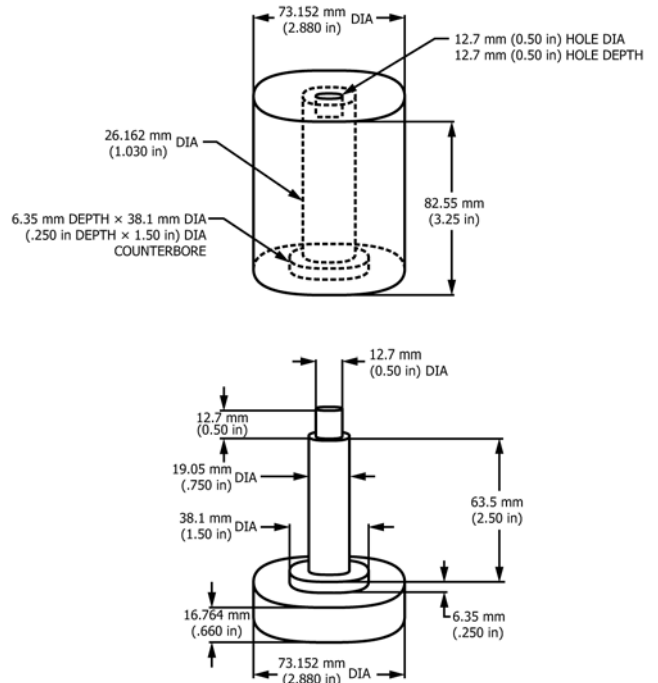

FIG. 1 Core Splice Adhesive Mold

the layer of adhesive overlaps along a vertical seam. Close the mold by lowering the female portion over the male portion until it seats against the base of the male portion. A press may be used to help close the mold. Remove the mold from the press and place in an oven. Cure in the oven at 121 ± 5.6°C (250 ± 10°F) for 1 h minimum. Remove cured adhesive from the mold.

NOTE 1—The mold may be made of aluminum, acrylic plastic, or other suitable material. The outer shell may be fabricated as a split mold.

NOTE 2—Depending on the expansion ratio and the unexpanded thickness of the material being tested, it may be necessary to install more than one layer of adhesive. The size of the adhesive shall be calculated as follows: Length × width × thickness = 1.65 cm³ (0.65 in.³).

6.1.2 Prepare the sample (approximately 38 mm (1½ in.) long) by cutting the cylinder of cured adhesive and visually check to ensure that there are no cracks, pin holes, and so forth.

6.1.3 Cover a piece of aluminum (approx. 50 × 50 × 6 mm) (2 × 2 × ¼ in.) with MIL-S-8802, Class B-2 Sealant, or equivalent, to a depth of 3 to 6 mm (⅛ to ¼ in.). Use a “dam,” such as vacuum-bagging putty or an aluminum foil tray, around the edge of the aluminum to prevent the sealant from running off (see Fig. 2).

6.1.4 Place the prepared sample of adhesive (6.1.2) on the sealant and seat it gently into the sealer. Allow the sealant to cure at room temperature overnight.

6.1.5 Install a glass tube approximately 38 mm (1½ in.) long approximately 19 mm (¾ in.) down into the hole in the top of the specimen, and seal between the glass tube and the test specimen with MIL-S-8802, Class B-2 sealant, or equivalent. Allow the sealant to cure at room temperature overnight.

6.1.6 Fill the cell in the sample through the glass tube with distilled water using a hypodermic needle. Inject the water at the bottom to ensure that the cell is full and that no air is entrapped. Measure the volume required to fill the cell.

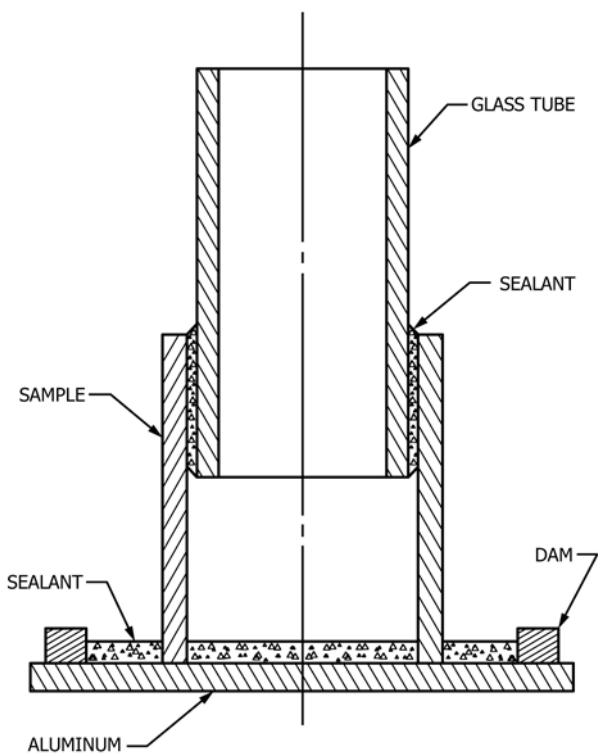

FIG. 2 Water Migration Test Specimen Assembly

6.1.7 Connect a buret filled with distilled water to the glass tube using a clear polyethylene tubing (see Fig. 3). Adjust the buret to a height of 914.4 mm (36 in.) above the top of the test specimen and ensure that there is no entrapped air.

6.1.8 The water migration through the adhesive tube specimen shall not exceed the number of millilitres required to fill the cavity (approximately 12 mL (0.4 oz)) when subjected to a 915 mm (36-in.) head for 24 h.

6.2 *Volatile Test*—Volatility of the film adhesive shall be tested in accordance with the procedure in 6.2.1 – 6.2.9.

6.2.1 Cut the adhesive into three one-ply test specimens. Each specimen is to be a 51-mm (2-in.) diameter disk or 51 by 51-mm (2 by 2-in.) square.

6.2.2 Weigh the containers that will be used in the cure of the test specimens cut in 6.2.1. Each container shall be an aluminum moisture dish, of sufficient size to allow the specimen to lie in the bottom without the edges of the specimen touching the side of the container. (W_1 = weight of container.)

6.2.3 Place each specimen in a container, then place the containers in a desiccator that contains a desiccant such as dryerite for 2 h \pm 10 min at room temperature, 24 \pm 3°C (75 \pm 5°F).

6.2.4 Remove the container and specimen from the desiccator and weigh. This weight shall be designated as W_2 . (W_2 = weight of container plus weight of uncured adhesive.)

6.2.5 Cure the specimens in a forced-air circulating oven. The time and temperature shall be in accordance with 5.3.2.1. When a cure temperature range is specified, the volatility test shall be conducted at the maximum curing temperature.

6.2.6 Remove the containers and cured specimens from the oven while at cure temperature, and place in a desiccator and cool to room temperature, 24 \pm 2.8°C (75 \pm 5°F).

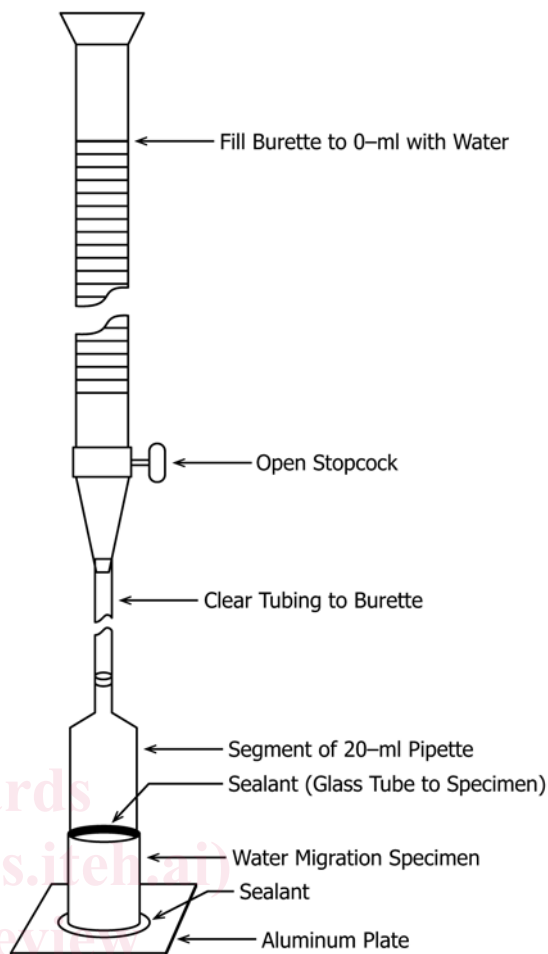

FIG. 3 Water Migration Test

6.2.7 Remove the cooled containers and specimens from the desiccator and reweigh. This weight shall be designated as W_3 . (W_3 = weight of cured adhesive and container.)

6.2.8 The percent weight loss shall be calculated as follows:

$$V = \frac{W_2 - W_3}{W_2 - W_1} \times 100 \quad (1)$$

where:

- V = weight loss (volatility), %,
- W_1 = weight of container, g (oz),
- W_2 = weight of container plus weight of uncured adhesive, g (oz), and
- W_3 = weight of cured adhesive and container, g (oz).

6.2.9 The percent of weight loss of three specimens shall be averaged and reported as volatility.

6.3 *Expansion Test*—Cut three specimens of the core splice adhesive (approx. 102 \times 102 mm) (4 \times 4 in.) with the liners intact. Record the average thickness (at least three readings per specimen) of the core splice adhesive and protective liners to nearest 0.025 mm (0.001 in.). Remove one liner and place the adhesive, exposed face down, on a piece of heat resistant release material, being careful to eliminate entrapped air between the core splice adhesive and the release material. Remove the second original liner from the adhesive and cure