



Designation: **D4289 – 03 (Reapproved 2008) D4289 – 13**

## Standard Test Method for Elastomer Compatibility of Lubricating Greases and Fluids<sup>1</sup>

This standard is issued under the fixed designation D4289; the number immediately following the designation indicates the year of original adoption or, in the case of revision, the year of last revision. A number in parentheses indicates the year of last reapproval. A superscript epsilon ( $\epsilon$ ) indicates an editorial change since the last revision or reapproval.

*This standard has been approved for use by agencies of the U.S. Department of Defense.*

### 1. Scope—Scope\*

1.1 This test method evaluates the compatibility of lubricating greases and fluids with coupons cut from standard elastomer sheets (Practice [D3182](#)) or, optionally, from SAE Specification AMS ~~3217/2B~~[3217/2C](#) (NBR-L) and AMS 3217/3A (CR) sheets. Compatibility is evaluated by determining the changes in volume and Durometer A hardness that occur when elastomer coupons are totally immersed in a lubricant sample for 70 h at either 100 or 150°C or as required by the lubricant specification.

1.1.1 Some lubricant specifications may require different test conditions, such as longer durations or lower or higher temperatures. In such instances, the repeatability and reproducibility values stated in Section [12](#) do not apply, and the user and supplier should agree on acceptable limits of precision.

NOTE 1—The scope of this test method now includes the evaluation of the elastomer compatibility of both lubricating fluids and greases. Testing of fluids was not included in Test Method D4289–95 and earlier versions.

1.2 This test method can also be used as a guide to evaluate the compatibility of greases with rubber products not in standard sheet form (Practice [D3183](#)).

1.3 The values stated in SI units are to be regarded as standard. No other units of measurement are included in this standard.

1.3.1 *Exception*—When listed, Durometer A units shall be regarded as the standard.

1.4 *This standard does not purport to address all of the safety concerns, if any, associated with its use. It is the responsibility of the user of this standard to establish appropriate safety and health practices and determine the applicability of regulatory limitations prior to use.* For specific warning statements, see [8.4 – 8.6](#).

### 2. Referenced Documents

#### 2.1 ASTM Standards:<sup>2</sup>

[D217](#) Test Methods for Cone Penetration of Lubricating Grease

[D297](#) Test Methods for Rubber Products—Chemical Analysis

[D412](#) Test Methods for Vulcanized Rubber and Thermoplastic Elastomers—Tension

[D471](#) Test Method for Rubber Property—Effect of Liquids

[D1193](#) Specification for Reagent Water

[D2240](#) Test Method for Rubber Property—Durometer Hardness

[D3182](#) Practice for Rubber—Materials, Equipment, and Procedures for Mixing Standard Compounds and Preparing Standard Vulcanized Sheets

[D3183](#) Practice for Rubber—Preparation of Pieces for Test Purposes from Products

[D4175](#) Terminology Relating to Petroleum, Petroleum Products, and Lubricants

[D4950](#) Classification and Specification for Automotive Service Greases

#### 2.2 Federal Standards:<sup>3</sup>

Federal Test Method Standard 791C, Method 3603.5, Swelling of Synthetic Rubbers

#### 2.3 U.S. Air Force Specifications:<sup>4</sup>

USAF-539 Specification Bulletin for Standard Elastomer Stocks

<sup>1</sup> This test method is under the jurisdiction of ASTM Committee [D02](#) on Petroleum Products—Products, Liquid Fuels, and Lubricants and is the direct responsibility of Subcommittee [D02.G0.01](#) on Chemical and General Laboratory Tests.

Current edition approved May 1, 2008 Dec. 1, 2013. Published September 2008 February 2014. Originally approved in 1989. Last previous edition approved in 2003 2008 as [D4289](#) [D4289 – 03 \(2008\)](#), ~~03~~. DOI: [10.1520/D4289-03R08](#); [10.1520/D4289-13](#).

<sup>2</sup> For referenced ASTM standards, visit the ASTM website, [www.astm.org](#), or contact ASTM Customer Service at [service@astm.org](#). For *Annual Book of ASTM Standards* volume information, refer to the standard's Document Summary page on the ASTM website.

<sup>3</sup> Available from Standardization Documents Order Desk, Bldg. 4, Section D, 700 Robbins Ave., Philadelphia, PA 19111-5094, Attn: NPODS.

<sup>4</sup> USAF-539 is obsolete, but reproductions have been filed at ASTM International Headquarters and may be obtained by requesting Research Report RR:D02-1165.

\*A Summary of Changes section appears at the end of this standard

## 2.4 SAE Standards:<sup>5</sup>

**AMS 3217A Standard Elastomer Stocks—Test Slabs**

**AMS ~~3217/2B~~3217/2C Test Slabs, Acrylonitrile Butadiene (NBR-L)—Low Acrylonitrile, 65–75**

**AMS 3217/3A Test Slabs, Chloroprene (CR)—65–75**

NOTE 2—USAF-539 was specified in Test Method D4289–94 and earlier versions. This specification is obsolete and has been replaced by SAE Standard AMS 3217A. USAF-539 NBR-L ~~has been~~ was replaced by SAE AMS ~~3217/2B~~3217/2C (NBR-L), which is virtually identical. USAF-539 CR has been replaced by the similar, but not identical, SAE AMS 3217/3A (CR). Elastomer sheets prepared to this latter specification are not known or expected to provide test results identical with those of the USAF-539 counterpart.

NOTE 3—With respect to elastomer AMS 3217/2A, the elastomer specification ~~has been~~ was superseded by AMS 3217/2B. Per SAE, the elastomers are identical, however, the synthetic lubricant immersion fluid used to reference the elastomer has been exchanged from ARM-200 to AMS 3021. Reference fluid AMS 3021 better represents current market aviation fluids.

NOTE 4—With respect to elastomer AMS 3217/2B, the elastomer is no longer being made by the original supplier and has been superseded by AMS 3217/2C. This material is made by Rubber-Tech (Mr. Forest Back, or Leah Lark, LLark@DNACO.net, Rubber-Tech, 5208 Wadsworth Road, Dayton, Ohio 45414, phone 937-274-1114) and has been approved for use by SAE. Limited testing of the new material compared with AMS 3217/2B material appears to show no bias but more in-depth evaluation is impossible due to lack of the older material.

## 2.5 ASTM Adjuncts:

ADJD6300 D2PP, Version 4.43, Determination of Precision and Bias Data for Use in Test Methods for Petroleum Products<sup>6</sup>

## 3. Terminology

### 3.1 Definitions:

3.1.1 *elastomer, n*—a natural or synthetic polymer having the rubber-like property of substantially recovering its size and shape after removal of a deforming force.

3.1.2 *hardness, n—of an elastomer*, the resistance to deformation or indentation.

#### 3.1.2.1 Discussion—

In this test method the hardness of an elastomer is measured with a Shore Durometer A (see Test Method **D2240**).

3.1.3 *lubricant, n*—any material interposed between two surfaces that reduces the friction or wear between them. **D4175**

3.1.4 *lubricating grease, n*—a semifluid to solid product of a dispersion of a thickener in a liquid lubricant.

#### 3.1.4.1 Discussion—

The dispersion of the thickener forms a two-phase system and immobilizes the liquid lubricant by surface tension and other physical forces. Other ingredients imparting special properties are often included. **D217**

3.1.5 *relative density, n*—the ratio of the density of a material at temperature,  $t_1$ , to the density of water at a reference temperature,  $t_2$ .

#### 3.1.5.1 Discussion—

In this test method relative density is determined with the temperature of the elastomer and water being equal and within the range from 20 to 25°C, and the temperature correction for the density of water is not applied. The term, *relative density*, replaces the synonymous, deprecated term, *specific gravity*, used in some earlier editions of this test method.

3.1.6 *thickener, n—in a lubricating grease*, a substance composed of finely divided particles dispersed in a liquid lubricant to form the product's structure.

#### 3.1.6.1 Discussion—

The thickener can be fibers (such as various metallic soaps) or plates or spheres (such as certain non-soap thickeners) which are insoluble or, at most, only very slightly soluble in the liquid lubricant. The general requirements are that the solid particles be extremely small, uniformly dispersed, and capable of forming a relatively stable, gel-like structure with the liquid lubricant. **D217**

### 3.2 Definitions of Terms Specific to This Standard:

3.2.1 *coupon, n*—a test piece of specified dimensions cut from standard elastomer sheets. **D3182**

### 3.3 Symbols:

3.3.1 Symbols used in the calculation of hardness change (see Eq 1 in 10.1):

$\Delta H$  = hardness change, Durometer A units,  
 $H_i$  = initial hardness, Durometer A units,  
 $H_f$  = final hardness, Durometer A units.

3.3.2 Symbols used in the calculation of relative density (see Eq 2 in 10.2) and volume change (see Eq 3 in 10.3):

$RD$  = relative density,  
 $\Delta V$  = volume change, %,   
 $M1$  = initial mass of coupon in air, g,  
 $M2$  = initial mass of coupon and hanger wire in water less mass of hanger wire partially submerged in water, g,  
 $M3$  = final mass of coupon in air, g,  
 $M4$  = final mass of coupon and hanger wire in water less mass of hanger wire partially submerged in water, g.

## 4. Summary of Test Method

4.1 A prepared elastomer coupon is measured for initial hardness (Durometer A), density or relative density (to ensure that the coupon is within specified limits), and volume by water displacement. The coupon is immersed in test grease or fluid and aged for 70 h at either 100°C (for chloroprene and similar flex-resistant elastomers) or 150°C (for nitrile and similar heat-resistant elastomers) or at other conditions as required by the lubricant specification. The resulting changes in hardness and volume are determined.

## 5. Significance and Use

5.1 Measurement of the changes in the volume and hardness of an elastomer that occur from immersion in a lubricating grease or fluid provides a means for evaluating relative compatibility. Much of this test method was derived from procedures described in Test Method D471 and Federal Test Method 791C/3603.5. In contrast to these two test methods, which emphasize the evaluation of rubber and rubber-like compounds, Test Method D4289 was developed specifically to evaluate lubricating greases and fluids, especially those used in automotive applications, although the test method can be applied to lubricants used in industrial applications as well. Excepting the Shore Durometer A, this test method requires no specialized, rubber-testing equipment. Virtually all other equipment and supplies specified in the procedure are stock items in lubricants laboratories.

5.2 The volume and hardness-change values determined by this test method do not duplicate similar changes that occur in elastomeric seals under actual service conditions. However, they can be correlated in many instances. In one such instance, the volume-change values determined by the antecedent of this test method correlated ( $r^2 = 0.99$ ) with those that occurred during a vehicle test.<sup>7</sup> Because of wide variations in service conditions and differences in grease and elastomer formulations, correlations between the results obtained with this test method and particular applications should be determined on an individual basis.

5.3 When the optional Reference Elastomers AMS 3217/2B3217/2C (acrylonitrile-butadiene, NBR-L) and AMS 3217/3A (chloroprene, CR) are used to evaluate compatibility, the results can be used to judge a service characteristic of lubricants. In this respect, this test method is useful for lubricant specifications (for example, Specification D4950). Similarly, this test method can be used in specifications for lubricating fluids as well.

5.4 With specifications requiring elastomers other than Reference Elastomers AMS 3217/2B3217/2C or AMS 3217/3A, coupons cut from standard sheets (Practice D3182) should be used. When the preparation of such coupons is not feasible, or the lubricant specification requires the use of rubber products that do not have a suitable size or configuration for use in preparing coupons for testing (Practice D3183), this test method can be used as a guide for evaluating compatibility.

NOTE 5—Inasmuch as the precision values apply only to the elastomers specified in Annex A1 of Test Method D4289, when a lubricant specification requires some other elastomer, the user and supplier of the lubricant should agree to the values of acceptable precision. Such values may or may not be the same as those of Test Method D4289. It is recommended that the agreed upon precision values be stated in the user's lubricant specification.

5.5 The results of this test method are most applicable to the use of lubricating greases and fluids in contact with elastomeric seals, boots, O-rings, and similar products, where the physical demands on the elastomer are not extreme. In critical applications where the lubricant will be in contact with rubber parts subject to severe flexing, extreme temperatures, or similar stresses, other rubber properties, such as tensile strength and elongation, should also be evaluated as they may be more indicative of the true compatibility characteristics.

## 6. Interferences

6.1 (**Warning**—Although greases and elastomers typically have long shelf lives, there is potential for change in time. Therefore, in order to ensure acceptable precision in this test method, neither test greases nor test elastomers should be more than approximately one year old.)

<sup>7</sup> Verdura, T. M., "Evaluating Compatibility of Greases with Elastomeric Seals," *NLGI Spokesman*, Vol 42, 1978, pp. 20–29.

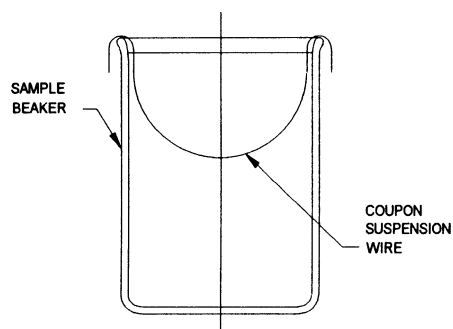

FIG. 1 Coupon Suspension Wire for Fluid Samples

6.1.1 Before testing with reference elastomers stored for extended periods (approaching one year or more) or in an adverse environment (high ambient temperatures, solvent vapors, and so forth), the elastomers should be checked for conformance with the requirements in Table A1.1.

NOTE 6—Experience has shown that storage conditions can affect the shelf life of the reference elastomers. Shelf life can be extended by storing elastomers in the dark in an inert atmosphere (such as a glass or metal, but not plastic, container, for example, vacuum desiccator, in which the air has been replaced by nonreactive gas (such as argon or nitrogen) at refrigerator temperatures. Elastomers should not be stored at temperatures lower than 5°C because of crystallinity and solubility changes that can affect test performance. Neither should they be stored at reduced pressures or in permeable containers or wrappers which could allow them to be affected by the normal atmosphere.

## 7. Apparatus

7.1 *Sample Beaker*, heat-resistant glass, Griffin low form, approximately 50 mm in diameter by 70 mm deep (100-mL nominal capacity), having volumetric markings.

7.2 *Beaker Cover*, disposable, aluminum foil weighing (moisture) dish, with crimped sides and flat, smooth bottom, about 0.1 mm thick, having bottom inside diameter approximately 52 mm and a depth of approximately 14 mm, and a capacity of about 50 mL.

7.3 *Analytical Balance*, having a sensitivity of at least 1 mg, equipped with a suspension hook and a platform to locate a hydrostatic-weighing beaker above the balance pan.

7.4 *Hanger Wire*, stainless steel, about 0.5-mm diameter (No. 25 U.S. Steel Wire Gage or Imperial Wire Gage) of suitable length, having a fish-hook configuration, that is, with a suitably sized eye at one end and a hook configuration (approximately 8-mm gape) at the other.

7.5 *Coupon Suspension Wire*, stainless steel, about 0.71 to 0.72-mm diameter (No. 22 U.S. Steel Wire Gage or Imperial Wire Gage), configured as shown in Fig. 1, to suspend the coupon below the surface of a fluid sample.

7.6 *Laboratory Oven*, circulating-air type, capable of maintaining the test temperature within  $\pm 2.5^\circ\text{C}$  and equipped with one or more grill-type, wire shelves.

7.7 *Shore Durometer A*, stand-mounted type (see Test Method D2240).

7.8 *Coupon Cutting Die*, optional, as shown in Fig. 2 (recommended).

## 8. Reagents and Materials

8.1 *Purity of Reagents*—It is intended that reagent grade chemicals be used in all tests. Unless otherwise indicated, all reagents shall conform to the specifications of the Committee on Analytical Reagents of the American Chemical Society, where such specifications are available.<sup>8</sup> Other grades may be used, provided it is first ascertained that the reagent is of sufficiently high purity to permit its use without lessening the accuracy of the determination.

8.2 *Purity of Water*—References to water shall be understood to mean distilled or deionized reagent water conforming to the requirements of Specification D1193, Type III.

8.3 *Reference Elastomers*—Optional, sheets, SAE Aerospace Material Specifications AMS 3217/2B3217/2C (acrylonitrile-butadiene, NBR-L) and AMS 3217/3A (polychloroprene, CR).

NOTE 7—Contact ASTM International for information regarding reference elastomer suppliers (see Research Report RR:D02-1166 listed in Section 12). When placing purchase orders with suppliers, Reference Elastomers, SAE Specification AMS 3217/2B3217/2C or AMS 3217/3A, respectively, must be specified to ensure shipment of the proper compound. Orders should require that each slab should be identified with the specification number, including

<sup>8</sup> *Reagent Chemicals, American Chemical Society Specifications*, American Chemical Society, Washington, DC. For suggestions on the testing of reagents not listed by the American Chemical Society, see *Analar Standards for Laboratory U.K. Chemicals*, BDH Ltd., Poole, Dorset, and the *United States Pharmacopeia and National Formulary*, U.S. Pharmacopeial Convention, Inc. (USPC), Rockville, MD.

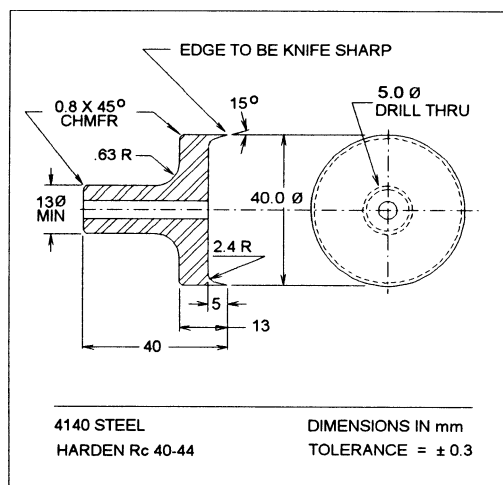

FIG. 2 Coupon Cutting Die (Optional)

suffix letter, and date of manufacture and should be accompanied by a report of normal inspection data for that batch.

8.3.1 Although the use of SAE Reference Elastomers AMS 3217/2B3217/2C and AMS 3217/3A is optional in the operation of this test method, when used, they must conform to the requirements of SAE Specifications AMS 3217A, AMS 3217/2B, 3217/2C, and AMS 3217/3A, which describes their composition, preparation, and properties. The physical properties used for inspection of these reference elastomers are summarized in Annex A1.

8.3.2 To ensure procurement of the proper compound, purchase orders for Reference Elastomers, SAE Specification AMS 3217/2B3217/2C or AMS 3217/3A, shall specify that each reference elastomer sheet be identified with the SAE specification number, including the correct suffix letter (see 8.3 or the lubricant specification), and the date of manufacture, and that the shipment of each batch should be accompanied by a report of normal inspection data for that batch (see Annex A1, for example).

NOTE 8—Revisions to the parent specification, SAE AMS 3217A, and its collateral specifications, AMS 3217/2B3217/2C (NBR-L) and AMS 3217/3A (CR), are indicated by changes in the suffix letter. Lubricant specifications should specify the required suffix letter; which may not be the same as that of the most recent version of SAE AMS 3217. Purchasers of reference elastomers should inform suppliers that reference compounds must be exactly as specified and that substitutions are not allowed even if the SAE specification has been updated.

8.4 *n-Heptane*, reagent grade. (Warning—Flammable. Health hazard.)

8.5 *Methanol (Absolute)*, reagent grade. (Warning—Flammable. Health hazard.)

8.6 *Wetting Agent Solution*, approximately 0.5 % dioctyl sodium sulfosuccinate, made by a suitable dilution of concentrated solution with reagent water.<sup>9</sup> (Warning— Eye irritant.

8.7 *Cheesecloth or Gauze Pad*, 100 % cotton.

8.8 *Blotting Paper*, flat, smooth, absorbent filter paper.

8.9 *Protective Gloves*.

## 9. Procedure

9.1 Cut elastomer coupons from standard, 2-mm thick, vulcanized sheets (Practice D3182) or, optionally, from AMS 3217/2B3217/2C or AMS 3217/3A sheets. Do not include any part of the thicker, identification portion of the sheet as part of the coupon. Trim off any edge flashing, if present. The coupon dimensions should be approximately 50 by 25 mm, 35 by 35 mm, or, preferably, die-cut, 40-mm diameter. Coupons cut to these dimensions will maintain a consistent, elastomer-to-sample volume ratio.

9.1.1 When using the cutting die for coupon preparation, back up the elastomer slab with a suitable surface, such as a plastic (preferred) or hardwood kitchen cutting board. Strike the die with a hammer or, preferably, use an arbor press to cut out the coupon. The die should not be turned in a drill press as this can cause heat distress on the cut edges of the coupon. From time to time, inspect the cutting edge of the die and resharpen as required.

9.1.2 With a leather punch or cork borer, punch or cut a 4 to 5-mm diameter hole near the edge (near the center of a short edge if a rectangular coupon is used). Corners or small radiused notches can be cut for identification; do not cut V-notches.

<sup>9</sup> Preparation of the wetting agent solution from the solid reagent is not recommended. Concentrated solutions of dioctyl sodium sulfosuccinate are available from suppliers of laboratory chemicals as Laboratory Aerosol or Aerosol OT (registered trademark of American Cyanamid Co.).

9.2 Stack three coupons having the same configuration to obtain the requisite, minimum 6-mm thickness (see Section 6 of Test Method **D2240**). Using the Durometer presser foot, apply sufficient force to ensure intimate contact between the stacked coupons and that the stack remains flat after removal of the force. Determine the initial, Shore Durometer A hardness,  $H_i$  of the elastomer coupon in accordance with Test Method **D2240**.

9.3 The reagent water must be freshly boiled to prepare it for hydrostatic weighings. Pour a sufficient amount of reagent water into a clean, heat-resistant, glass beaker (600 mL or larger) and boil vigorously for approximately 5 min; cover the beaker with a clean watchglass, and cool to 20 to 25°C.

9.4 Weigh the hanger wire both in air and partially submerged (10 to 15 mm) in the prepared reagent water. The entire hook portion of the hanger wire is to be completely submerged. Record the immersion depth, as well as both mass determinations, for later reference. For these and all subsequent weighings, the mass determinations are to be to the nearest milligram, at least.

NOTE 9—Marking the water level on the outside of the beaker can be beneficial in attaining the same immersion depth for the determination of M2 and M4 (see 9.6.5 and 9.21, respectively).

9.5 Wipe the coupon with *n*-heptane-wetted cheesecloth to remove any mold-release compound that may be present on the surface. Gently blow dry with nitrogen or clean, dry, pressurized air. Alternatively, blot dry with cheesecloth or filter paper. Remove any adhering cloth or paper fibers.

9.6 After the *n*-heptane has evaporated completely, determine the volume and relative density,  $RD$ , of the specimen by water displacement.

9.6.1 If the elastomer specification has a requirement for density or relative density but does not specify the test method for its determination, use the Hydrostatic Method described in Test Method **D297**. If the specification has neither a density nor a relative density requirement, determine relative density in accordance with 9.6.2 through 9.6.7.

9.6.2 Weigh the coupon in air to determine  $M_1$ . The hanger wire may be included in the weighing; if it is used, subtract its mass in air from the combined mass to determine  $M_1$ .

9.6.3 Using the hanger wire, dip the coupon successively in beakers of wetting agent solution and reagent water. Drain momentarily after each dipping by touching the lower edge of the coupon against the rim of the beaker.

9.6.4 Suspend the hanger wire and coupon from the balance hook so that the hanger is submerged in prepared reagent water to the same depth as in 9.4. Inspect the submerged coupon, and remove any adhering air bubbles. If the bubbles are difficult to remove, repeat 9.6.3. In uncommon instances, it may be necessary to devise a means of mechanically dislodging adherent air bubbles.

9.6.5 Weigh the combined mass of the submerged hanger and coupon, and calculate  $M_2$  by subtracting the mass of the hanger wire partially submerged in water to the same depth described in 9.4.

9.6.6 Dip the coupon in methanol and blot it dry with filter paper.

9.6.7 Calculate the relative density,  $RD$ , in accordance with 10.2. Discard the coupon if it does not meet the density or relative density requirements of the elastomer specification or as described in 9.7 or 9.8.

9.7 If the density or relative density is not specified, conduct replicate tests or tests with multiple lubricant samples only with coupons that are within 0.010 of the mean relative density to ensure satisfactory precision. Coupons outside these limits should be discarded.

NOTE 10—Although Test Method D4289 provides no information regarding the precision of density or relative density measurements, operators are frequently concerned about the repeatability of their own determinations. Typically, good laboratory skills by an operator will be confirmed by a coefficient of variation (CV) of less than 0.05 % for a series of values obtained with one batch of elastomer. If the CV is significantly greater than 0.1 %, the operator should improve his technique.

9.8 When using SAE Reference Elastomers AMS 3217/2B3217/2C or AMS 3217/3A (NBR-L or CR, respectively), the coupons must conform to the density (Test Method **D297**) and other requirements given in Table A1.1. Discard any reference elastomer coupons that do not meet the requirements shown in Table A1.1.

9.9 Lubricant samples should be homogeneous. Thoroughly mix fluid samples having potential for additive separation. Stir grease samples if separated oil is present.

9.10 If only grease samples are to be tested, skip to 9.12 to continue.

9.11 *For Fluid Samples*—Fill the beaker with the test fluid to the 80-mL mark. Place one coupon on a coupon suspension wire and insert into beaker making sure coupon is completely immersed.

9.11.1 If only fluid samples are to be tested, skip to 9.13 to continue.

9.12 *For Grease Samples*—When the physical properties of the grease will allow insertion of the coupon without occluding air, fill the beaker with test grease to the 80-mL mark, then insert the coupon in an upright position. Fill in all voids that may have been created while packing the test grease and coupon into the beaker.

9.12.1 Alternatively, distribute about 20 mL of the test grease in the bottom of the beaker, apply a thick coating (4 mm, min) of test grease on the elastomer coupon, and place the coupon upright in the beaker. Pack the test grease around the coupon, eliminating all air pockets to ensure intimate contact with the test coupon. Fill the beaker to the 80-mL mark with the test grease.