



Designation: F1790/F1790M – 14

## Standard Test Method for Measuring Cut Resistance of Materials Used in Protective Clothing with CPP Test Equipment<sup>1</sup>

This standard is issued under the fixed designation F1790/F1790M; the number immediately following the designation indicates the year of original adoption or, in the case of revision, the year of last revision. A number in parentheses indicates the year of last reapproval. A superscript epsilon ( $\epsilon$ ) indicates an editorial change since the last revision or reapproval.

### INTRODUCTION

Cut resistance is an important property for protective clothing and equipment, and several standard testing devices have been adopted across different industries to measure this property. A common practice in cut resistance testing is to subject a material specimen to a transversely moving blade under an applied load and measure the distance of blade travel required to cut through the specimen. This test method calculates the load required to cut through different specimens at 25.4 mm [1 in.] blade travel. This calculated load, defined as a rating load, can be used to compare the cut resistance of materials.

The original F1790-97 test method defined a commercially-available apparatus known as the Cut Protection Performance Tester (CPP). In an attempt to harmonize F1790/F1790M with ISO 13996 (another international testing standards for measuring cut resistance) and improve the test method, the scope of the test method was changed in F1790-05 to allow the use of other cut testing equipment, specifically the Tomodynamometer (TDM-100) and a modification to the CPP arm called the Modified CPP (mCPP). The revision addressed issues related to measurement of high frictional coefficient materials like elastomers, specimen mounting, rating load calculation, and other procedures to harmonize with ISO 13997:1999. After further round-robin evaluation by the subcommittee, it was demonstrated that the revisions to the test method result in a bias between the original F1790-97 test method and the revised F1790-05 test method when using the CPP. F1790-05 was not widely adopted in North America because of this bias and large amount of data and experience accumulated with F1790-97. F1790-97 continues to be the test method predominately practiced when using the CPP device. To reduce confusion for end-users of F1790/F1790M and to allow for differences between testing devices, the subcommittee has decided to limit the scope of F1790/F1790M to include only the CPP device and create a separate test method for use of the TDM-100.

### 1. Scope

1.1 This test method covers the measurement of the cut resistance of a material when mounted on a mandrel and subjected to a cutting edge under a specified load using the Cut Protection Performance (CPP) Tester.

1.1.1 This procedure is not valid for high-porosity materials which allow cutting edge contact with the mounting surface prior to cutting.

1.1.2 Test apparatus may have limitations in testing materials with a thickness greater than 3 mm or having a high frictional coefficient such as elastomers.

1.2 The values stated in either SI units or inch-pound units are to be regarded separately as standard. The values stated in each system may not be exact equivalents; therefore, each system shall be used independently of the other. Combining values from the two systems may result in non-conformance with the standard.

1.3 *This standard does not purport to address all of the safety concerns, if any, associated with its use. It is the responsibility of the user of this standard to establish appropriate safety and health practices and determine the applicability of regulatory limitations prior to use.*

<sup>1</sup> This test method is under the jurisdiction of ASTM Committee F23 on Personal Protective Clothing and Equipment and is the direct responsibility of Subcommittee F23.20 on Physical.

Current edition approved Jan. 1, 2014. Published February 2014. Originally approved in 1997. Last previous edition approved in 2005 as F1790 - 05. DOI: 10.1520/F1790\_F1790M-14.

## 2. Referenced Documents

### 2.1 ASTM Standards:<sup>2</sup>

**D123 Terminology Relating to Textiles**

**D1000 Test Methods for Pressure-Sensitive Adhesive-Coated Tapes Used for Electrical and Electronic Applications**

**D1776 Practice for Conditioning and Testing Textiles**

**F1494 Terminology Relating to Protective Clothing**

### 2.2 ISO Standards:<sup>3</sup>

**ISO 13996 Protective Clothing—Mechanical Properties—Determination of Resistance to Puncture**

**ISO 13997 Protective Clothing—Mechanical Properties—Determination of Resistance to Cutting by Sharp Objects**

### 2.3 ASTM Adjuncts:

Cut Test Video Demonstration<sup>4</sup>

## 3. Terminology

### 3.1 Definitions:

3.1.1 *cut resistance, n*—in blade cut testing, the property that hinders cut through when a material or a combination of materials is exposed to a sharp-edged device.

3.1.2 *cut through, n*—in blade cut resistance tests, the penetration of the cutting edge entirely through material, as indicated by electrical contact of the cutting edge and the conductive strip or substrate.

3.1.3 *cut through distance, n*—in cut resistance testing, the distance of required travel by the cutting edge to cut through the specimen.

3.1.4 *cutting edge, n*—in cut resistance tests, a sharp-edged device used to initiate cut through of a planar structure.

3.1.5 *no cut, n*—in cut resistance testing, a trial for which the load used is insufficient to cause a cut through in the maximum allowable blade travel of the apparatus.

3.1.5.1 *Discussion*—For this test method, the maximum allowable blade travel is 50.8 mm [2.0 in.].

3.1.6 *protective clothing, n*—an item of clothing that is specifically designed and constructed for the intended purpose of isolating all or part of the body from a potential hazard; or, isolating the external environment from contamination by the wearer of the clothing.

3.1.6.1 *Discussion*—In this test method, the potential hazard is cutting.

3.1.7 *rating load, n*—in cut resistance testing, the load required to cause a cutting edge to produce a cut through when it traverses the reference distance across the material being tested.

3.1.7.1 *Discussion*—The rating load is calculated by performing a series of tests at three or more loads as described in

Section 11. A material with a higher rating load is considered to be more cut resistant.

3.1.8 *reference distance, n*—in cut resistance testing, a standardized distance for a blade to travel across a material to produce a cut through.

3.1.8.1 *Discussion*—For this test method, the reference distance is 25.4 mm [1.0 in.].

3.2 *Additional Terminology*—Terms relevant to textiles are defined in Terminology **D123**. Terms relevant to protective clothing are defined in Terminology **F1494**.

## 4. Summary of Test Method

4.1 A cutting edge under a specified load is moved one time across a specimen mounted on a mandrel.

4.2 The cut through distance from initial contact to cut through, for each load.

4.2.1 A series of tests, at a minimum of three different loadings must be performed to establish a range and to determine the rating force.

4.3 The test method is repeated using multiple loads to calculate a rating load for the material.

## 5. Significance and Use

5.1 This test method assesses the cut resistance of a material when exposed to a cutting edge under specified loads. Data obtained from this test method can be used to compare the cut resistance of different materials.

5.2 This test method only addresses that range of cutting hazards that are related to a cutting action across the surface of the material. It is not representative of any other cutting hazard to which the material may be subjected such as serrated edges, saw blades or motorized cutting tools. Nor is it representative of puncture, tear, or other modes of fabric failure.

## 6. Apparatus

6.1 *Test Principle*—The principle of the cut test is to measure the distance traveled by a cutting edge as it is maintained under a load during the test. The cut test apparatus consists of the following primary components (see **Fig. 1**): (A) a pivoting motor-driven balance arm to hold the cutting edge and to which the load is applied, (B) a cutting edge; and (C) a fixed supporting mandrel on which the specimen is to be mounted. The apparatus should propel the cutting edge across the specimen until sufficient work is applied to cause the specimen to cut through.

6.2 *CPP Test Apparatus*<sup>5</sup>—The CPP test apparatus (see **Fig. 2**) consists of a motor-driven balance arm (A) that holds the cutting edge (B) in contact with the specimen mounted on a fixed supporting mandrel (C). The balance arm is connected to the motor using a drive wheel (D) and a connection arm

<sup>2</sup> For referenced ASTM standards, visit the ASTM website, [www.astm.org](http://www.astm.org), or contact ASTM Customer Service at [service@astm.org](mailto:service@astm.org). For *Annual Book of ASTM Standards* volume information, refer to the standard's Document Summary page on the ASTM website.

<sup>3</sup> Available from International Organization for Standardization (ISO), 1, ch. de la Voie-Creuse, CP 56, CH-1211 Geneva 20, Switzerland, <http://www.iso.org>.

<sup>4</sup> Available from ASTM Headquarters. Request Adjunct No. **ADJF1790**.

<sup>5</sup> The sole source of supply of the CPP Tester known to the committee at this time is Red Clay, Inc., 2388 Brackenville Rd., Hockessin, DE 19707, E-mail: [redclay@magpage.com](mailto:redclay@magpage.com). If you are aware of alternative suppliers, please provide this information to ASTM International Headquarters. Your comments will receive careful consideration at a meeting of the responsible technical committee,<sup>1</sup> which you may attend.

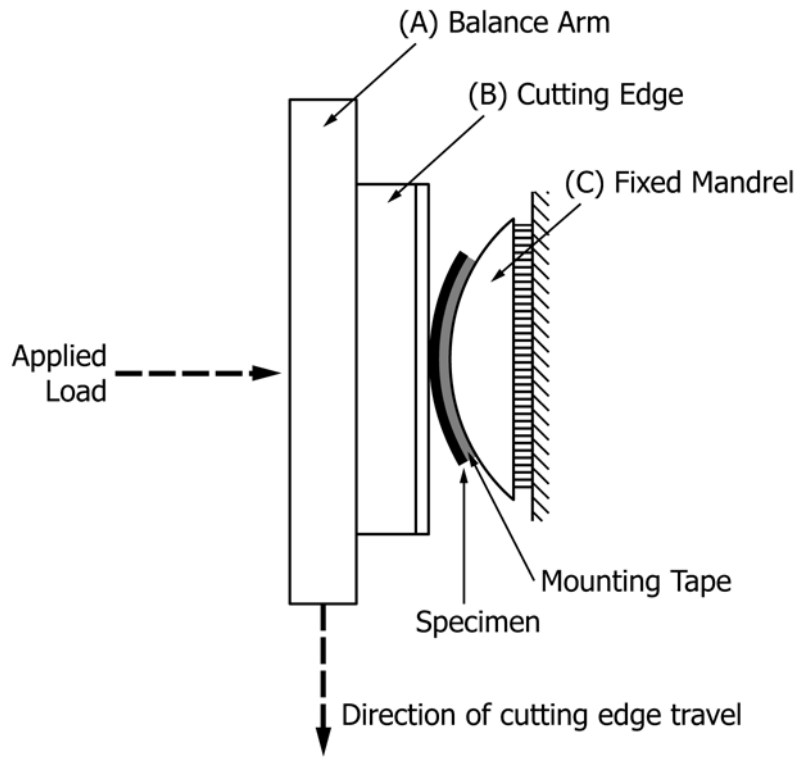

FIG. 1 Schematic of Cut Test Principle

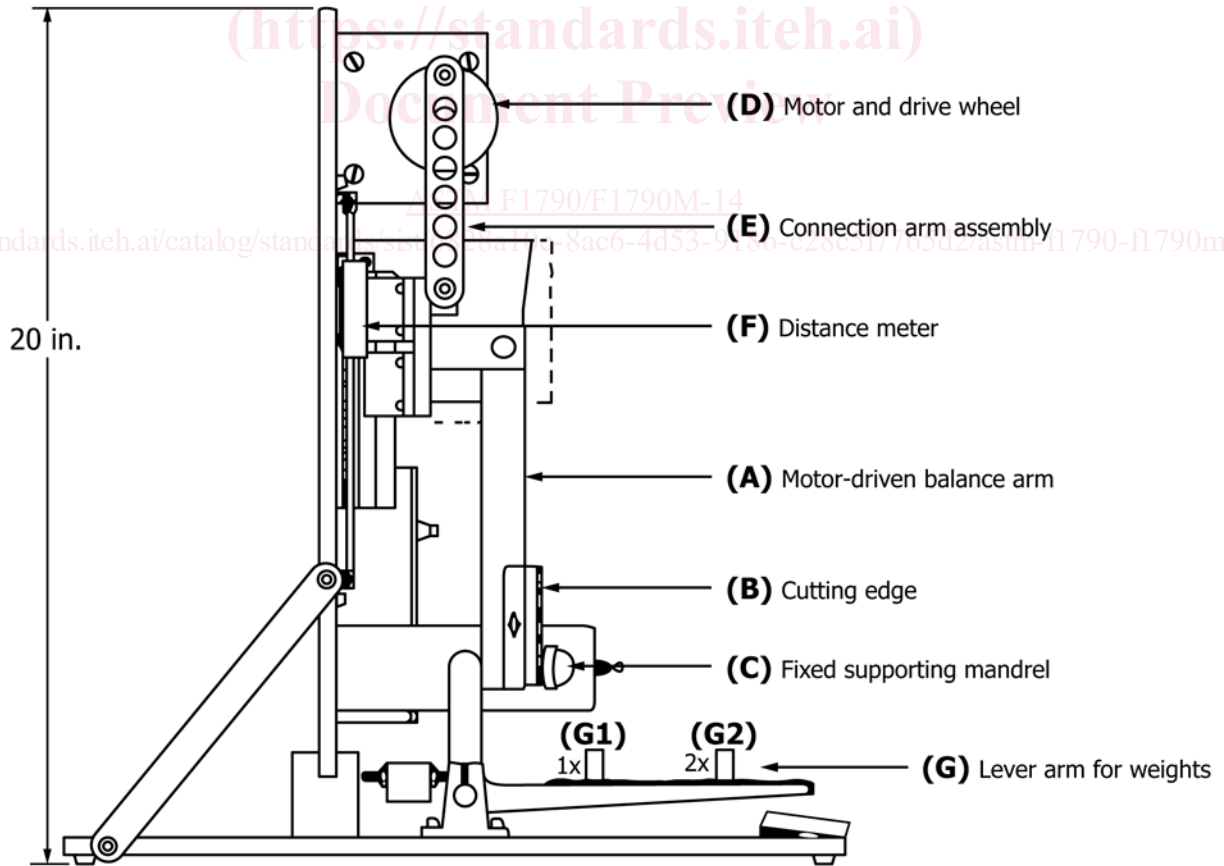

FIG. 2 Schematic of the CPP Tester (Side View)

assembly (E). The diameter of the drive wheel is 50.8 mm [2.0 in.], and the distance between the center of the drive wheel and attachment point of the pivot arm is 25.4 mm [1.0 in.] resulting in a maximum linear displacement of 50.8 mm [2.0 in.] for the balance arm and cutting edge. Cutting edge displacement is measured by a distance meter (F) attached to the balance arm and pivot arm assembly that is capable of measuring to 0.1 mm [0.004 in.]. Weights are placed on a pivoting lever arm assembly (G) to generate the load needed to penetrate the moving edge into the specimen and produce a cut through. The location of the weight on the lever arm will determine the resulting load. Weights placed on the location closest to the arm pivot (G1) will result in a load equal to the applied weight. Weights placed on the location furthest from the pivot (G2) will result in a load twice that of the applied weight. The apparatus must be capable of loads ranging from 10 g [0.35 oz] to 15 kg [33 lb].

6.2.1 *Cutting Speed*—The apparatus shall propel the cutting edge across the specimen at an average speed of 4.2 mm/s [0.17 in./s].

NOTE 1—Since the cutting edge is propelled by a rotating drive wheel, the resulting vertical speed is not constant during the test. The speed ranges from 0 mm/s at the start of the test, then reaching a maximum of 14 mm/s at the midpoint of the test, and then decreases back to 0 mm/s by the end of the test. The average speed blade during the test is thus 4.2 mm/s [0.17 in./s] as calculated using the equation for angular velocity.

6.2.2 *Cut Through Detection*—Cut through is detected by an electrical contact between the cutting edge and the supporting mandrel.

6.2.3 *Mandrel*—The top surface of the mandrel is a rounded form which has an arc of at least 32 mm [1.25 in.] in a circle having a radius of 38 mm [1.5 in.]. The surface of the mandrel shall be conductive and made of metal.

6.3 *Cutting Edge*—Single-edged razor blades<sup>6</sup> shall be used as the cutting edge. The blades shall be made of stainless steel with a hardness greater than 45 HRC. Blades shall be  $1.0 \pm 0.5$  mm [0.039  $\pm$  0.020 in.] thick and ground to a bevel width of  $2.5 \pm 0.2$  mm [0.098  $\pm$  0.008 in.] along a straight edge resulting in a primary bevel angle of  $22^\circ \pm 2^\circ$ . The blade should also contain a honed secondary bevel at the cutting edge with an inclined angle of  $36^\circ \pm 2^\circ$ . Blades shall have a cutting edge length greater than 65 mm [2.56 in.] and shall have a width greater than 18 mm [0.71 in.].

6.4 *Mounting Tape*—Double-sided tape<sup>7</sup> shall be used to secure the test specimen to the apparatus. The tape should have a cloth carrier and rubber-based adhesive on both sides with a total thickness of  $0.38 \pm 0.25$  mm, weight of  $473 \pm 33$  g/m<sup>2</sup>, and a minimum tensile strength of 90 N/cm (see Test Methods **D1000** for details on test methods for adhesive tape).

<sup>6</sup> Blade 88-0121 Type GRU-GRU textile blade available from Energizer Personal Care, LLC (formerly American Safety Razor Company) has proven satisfactory for this test method. The sole source of supply of blades known to the committee at this time is Energizer Personal Care, LLC, (formerly American Safety Razor Company), One Razor Blade Lane, Verona, VA 24482. If you are aware of alternative suppliers, please provide this information to ASTM International Headquarters. Your comments will receive careful consideration at a meeting of the responsible technical committee,<sup>1</sup> which you may attend.

<sup>7</sup> Polyken® 108FR Double-Coated Cloth Tape manufactured by Berry Plastics Corporation or equivalent has proven satisfactory for this test method.

## 7. Hazards

7.1 The cut test equipment can pose a potential hazard to the technician if proper safety precautions are not followed. The cut test apparatus is to be used only by authorized personnel that have been properly trained.

7.2 Store used blades in a sealed container.

7.3 Remove blades from the apparatus at the end of each test or when the apparatus is not in use.

7.4 Keep hands out of cutting area when a blade is installed in the apparatus and when the apparatus is operating.

7.5 Turn off machine before making instrument adjustments to avoid the chance of a low-voltage shock.

## 8. Sampling and Test Specimens

8.1 *Lot Sample*—As a lot sample for acceptance testing, take at random the number of shipping units directed in an applicable material specification.

8.2 *Laboratory Sample*—As a laboratory sample for acceptance testing, take at random from each shipping unit in the lot sample, the number of packages or pieces directed in an applicable material specification or other agreement between the purchaser and the supplier.

8.3 *Protective Clothing Sample*—A sample of actual Protective Clothing Article.

8.4 *Test Specimens:*

8.4.1 Take test specimens at random from each sample.

8.4.1.1 When performing up to fifteen cut tests per specimen, as when determining the reference load of the material, the specimen shall have a minimum dimension of 25.4 by 100 mm [1.0 by 4.0 in.].

8.4.1.2 For textile materials, cut the specimen on the bias as to create an angle of 0.785 rad (45°) between the machine and cross-machine directions of the material (see Terminology **D123** for the definition of machine directions of textile materials).

NOTE 2—For small samples of insufficient width to cut the sample on the bias, such as protective clothing, cut the test specimen parallel to the machine direction up to the maximum allowable width and then rotate it 0.785 rad (45°) when mounting it on the apparatus.

## 9. Calibration and Standardization

9.1 *Lever Arm Balancing*—With no weights installed on the lever arm of the apparatus, mount a blade in the holder and adjust the position of the lever arm counterweight until the edge of the blade touches the curved surface of the mandrel without exerting any visible force on the mandrel.

NOTE 3—The balance may be verified with gentle taps on the stand next to the machine. Any disturbance should cause the blade to fall away from the mandrel as the lever arm pivots.

9.2 *Lever Arm Load Calibration:*

9.2.1 Install a mandrel fitted with an electronic load cell into the apparatus.

9.2.2 Place known weights between 50 and 1000 g on the lever arm and record the force in gf indicated by the load cell for each.

9.2.3 Perform a linear regression analysis using Eq 1 with the weight values as the independent variable,  $x$ , and the force indicated by the load cell as the dependent variable,  $y$ :

$$y = mx + b \quad (1)$$

where:

- $y$  = force, gf
- $x$  = applied weight, g
- $m$  = slope (correction factor), and
- $b$  = intercept of slope.

9.2.4 The slope of the regression line,  $m$ , is the correction factor to be applied to the actual weights to determine the load on the blade.

9.2.5 Calibration of the lever arm load should be performed at least once a month and whenever the machine is moved.

### 9.3 Validation of Cutting Edge Supply:

9.3.1 *Calibration Material*—Calibration material is a neoprene sheet<sup>8</sup> having a hardness of  $50 \pm 5$  Shore A and a thickness of  $1.57 \pm 0.05$  mm [ $0.062 \pm 0.002$  in.].

9.3.1.1 Store the calibration material under controlled laboratory conditions described in Practice D1776 in an opaque container to prevent deterioration by heat or ultraviolet light.

#### 9.3.2 Blade Validation Procedure:

9.3.2.1 Take a specimen of the calibration material and follow the mounting procedure as described in 11.1.

9.3.2.2 Calculate the average cut through distance using a minimum of 1 blade out of 20 for each blade supply by performing a cut test with each blade following the test procedure described in 11.2 using a cutting load of 400 gf.

9.3.2.3 To be a valid blade supply, the average cut through distance for the blade supply must be between 18.0 and 38.0 mm [0.7 and 1.5 in.], and the cut through distances for all the tested blades in the supply should not differ by more than 10 mm [0.4 in.].

## 10. Conditioning

10.1 Condition test specimens as indicated in Practice D1776.

## 11. Procedure

### 11.1 Specimen Mounting:

11.1.1 Cover the mandrel surface with double-sided tape, and without stretching or distorting it, place the test specimen over the tape with the surface to be cut facing up. Apply firm pressure on the specimen to secure it to the mandrel.

NOTE 4—The tape can also be applied directly to the sample before the test specimen is cut and then mounted directly to the mandrel. This procedure is helpful for materials that curl or distort when being cut from the sample.

11.1.2 Insert the mandrel in the support column of the apparatus with the sample facing the motor-driven balanced

arm and align it so that the blade contact will be centered on the rounded surface. Tighten the mandrel in place.

11.2 *Test Procedure for Measuring the Cut Through Distance:*

11.2.1 Insert a new blade from a validated blade supply in the arm slot and tighten the blade clamping system.

NOTE 5—Refer to 9.3 for instructions on how to validate the blade supply.

11.2.2 Verify that the cutting arm is at the ready position making certain that only the blade edge and not the corner of the blade will touch the specimen. All cuts should be made with the blade moving downward.

11.2.3 Select and install weights to produce the desired cutting load.

11.2.4 Zero the blade travel distance meter.

11.2.5 Carefully ease the blade into contact with the specimen and immediately start the apparatus.

11.2.6 After cut through is detected and the motor arm stops, record the cut through distance.

11.2.6.1 If no cut through occurs within 50.8 mm [2.0 in.] of blade travel, stop the machine and indicate that the load was insufficient to cut through the specimen by reporting a *no cut*.

11.2.7 Lock the lever arm with blade retracted from the specimen, remove the weights, and discard the used blade.

### 11.3 Test Procedure for Determining the Rating Load:

11.3.1 Repeat the test procedure described in 11.2 using a minimum of three different loads. The loads should be distributed to produce cut through distances in the range of 5.0 to 50.8 mm [0.2 to 2.0 in.]. When performing multiple cut tests per specimen, each cut should be spaced a minimum of 6.35 mm [0.25 in.] from the previous cut.

11.3.1.1 Five replicated tests at each of three different loads have been found to be adequate; however, an alternate allocation of test loads may be considered for highly reinforced materials. If possible, the loads should be selected as to produce five data points in the 5 to 20 mm [0.2 to 0.8 in.] cut through distance range, five data points in the 20 to 33 mm [0.8 to 1.3 in.] cut through distance range, and five data points in the 33 to 50.8 mm [1.3 to 2.0 in.] cut through distance range. For more details on selecting the different loads to use with this procedure, see Appendix X1.

## 12. Calculation of Results

### 12.1 Blade Sharpness Correction:

12.1.1 Calculate the blade sharpness correction factor,  $C_s$ , of the blade supply by dividing 25.4 mm [1.0 in.] by the average cut through distance determined in the blade validation procedure described in 9.3.2.

12.1.2 Multiply the measured cut through distances recorded during the test by  $C_s$  to create normalized distance data.

### 12.2 Rating Load Calculation:

12.2.1 When testing specimens using multiple loads for the purposes of determining the rating load (see 11.3), perform an inverse regression analysis (see Notes Note 6 and 8) of the cutting loads and the log of the normalized cut through distances to estimate the rating load required to produce cut through at the reference distance of 25.4 mm [1.0 in.]. For

<sup>8</sup> Neoprene Style NS-5550 manufactured by Reeves Brothers, Inc. has proven satisfactory for this method. The sole source of supply of the Neoprene Style NS-5550, or equivalent, supplied by Reeves Brothers, Inc., Spartanburg, SC, known to the committee at this time is Red Clay, Inc., 2388 Brackenville Rd., Hockessin, DE 19707. If you are aware of alternative suppliers, please provide this information to ASTM International Headquarters. Your comments will receive careful consideration at a meeting of the responsible technical committee,<sup>1</sup> which you may attend.

**TABLE 1 Precision of the Test Method, Calculated Rating Load**

Note 8—

 $S_r$  = repeatability standard deviation,

 $r$  = repeatability = 2.80 times the square root of the repeatability variance,

 $S_R$  = reproducibility standard deviation, and

 $R$  = reproducibility = 2.80 times the square root of the reproducibility variance.

Material	Average Rating Load, gf	Within Laboratories		Between Laboratories	
		$S_r$	$r$	$S_R$	$R$
1	144	13	36	54	150
2	358	16	46	63	170
3	391	19	52	31	87
4	483	14	39	56	150
5	666	46	130	91	250
6	902	48	130	136	380
7	902	98	270	103	290
8	1311	69	190	180	500
9	3148	127	350	376	1040
10	4034	335	930	757	2100

more details about performing the regression analysis and an example calculation, refer to [Annex A1](#).

NOTE 6—The use of the common logarithm of the cut through distance when performing the regression analysis has been found to provide the most reliable method for estimating the rating load.

### 13. Interpretation of Results

13.1 Materials that can do either of the following are capable of delivering better cut resistance:

13.1.1 Provide higher cut resistance by demonstrating a longer distance traveled when equal loads are mounted.

13.1.2 Provide higher cut resistance by demonstrating resistance to higher loads at the same cut through distance, which can be accomplished by calculating the rating load for the material.

### 14. Report

14.1 Report the following:

14.1.1 Test was performed in accordance with Test Method F1790/F1790M-14.

14.1.2 Name and model number of the cut testing device used.

14.1.3 *Sample Identification*—Sample description of fabric or material to indicate construction, fiber (or blends), and areal density in  $\text{g/m}^2$  [ $\text{oz/yd}^2$ ].

14.1.4 Identification of blade supply designation and lot number.

14.1.5 Results of the blade validation indicating that the blade supply is valid.

14.1.6 *Test Result*:

14.1.6.1 Report the loads used, the measured cut through distances at each load, the calculated rating load, the standard deviation, and the coefficient of determination,  $R^2$ , of the regression analysis.

14.1.7 Report any variations in procedure from this test method.

### 15. Precision and Bias

15.1 An interlaboratory test program was conducted in 1995 to obtain precision data for calculating the rating load using the CPP.

15.2 Ten different materials were used in that interlaboratory program, these were tested in seven laboratories. Samples of ten materials were supplied to each laboratory and the rating load was determined. Duplicate determinations of the rating load were made in each of seven laboratories.

15.3 The results of the precision calculations for repeatability and reproducibility are given in [Table 1](#).

15.4 The precision of this test method may be expressed in the format of the following statements that use what is called an appropriate value of  $r$  or  $R$ , that is, that value to be used in decisions about test results (obtained with the test method). The appropriate value is that value of  $r$  or  $R$  associated with a mean level in [Table 1](#), closest to the mean level under consideration at any given time, for any given material in routine testing operations.

15.5 *Repeatability*—The repeatability,  $r$ , of this test method has been established as the appropriate value tabulated in [Table 1](#). Two single test results, obtained under normal test method procedures, that differ by more than this tabulated  $r$  (for any given level) must be considered as derived from different or non-identical sample populations.

15.6 *Reproducibility*—The reproducibility,  $R$ , of this test method has been established as the appropriate value tabulated in [Table 1](#). Two single test results obtained in two different laboratories, under normal test method procedures, that differ by more than the tabulated  $R$  (for any given level) must be considered to have come from different or non-identical sample populations.

15.7 *Bias*—In test method terminology, bias is the difference between an average test value and the reference (or true) test property value. Reference values do not exist for this test method since value (of the test property) is exclusively defined by the test method. Bias, therefore, cannot be determined.

### 16. Keywords

16.1 cut protection; cut resistance; cut through distance; protective clothing; rating load