

INTERNATIONAL STANDARD

ISO
3405

Second edition
1988-12-01



INTERNATIONAL ORGANIZATION FOR STANDARDIZATION
ORGANISATION INTERNATIONALE DE NORMALISATION
МЕЖДУНАРОДНАЯ ОРГАНИЗАЦИЯ ПО СТАНДАРТИЗАЦИИ

Petroleum products — Determination of distillation characteristics

Produits pétroliers — Détermination des caractéristiques de distillation

ITeH STANDARD PREVIEW

(standards.iteh.ai)

[ISO 3405:1988](https://standards.iteh.ai/catalog/standards/sist/d4b08379-a219-4a42-8620-420cb715b679/iso-3405-1988)

<https://standards.iteh.ai/catalog/standards/sist/d4b08379-a219-4a42-8620-420cb715b679/iso-3405-1988>

Reference number
ISO 3405 : 1988 (E)

Foreword

ISO (the International Organization for Standardization) is a worldwide federation of national standards bodies (ISO member bodies). The work of preparing International Standards is normally carried out through ISO technical committees. Each member body interested in a subject for which a technical committee has been established has the right to be represented on that committee. International organizations, governmental and non-governmental, in liaison with ISO, also take part in the work. ISO collaborates closely with the International Electrotechnical Commission (IEC) on all matters of electrotechnical standardization.

Draft International Standards adopted by the technical committees are circulated to the member bodies for approval before their acceptance as International Standards by the ISO Council. They are approved in accordance with ISO procedures requiring at least 75 % approval by the member bodies voting.

International Standard ISO 3405 was prepared by Technical Committee ISO/TC 28, *Petroleum products and lubricants*.

[ISO 3405:1988](#)

This second edition cancels and replaces the first edition (ISO 3405 : 1975), of which it constitutes a technical revision.

<https://standards.iteh.ai/catalog/standards/sist/d4b08379-a219-4a42-8620-420c67156679/iso-3405-1988>

Users should note that all International Standards undergo revision from time to time and that any reference made herein to any other International Standard implies its latest edition, unless otherwise stated.

Petroleum products — Determination of distillation characteristics

1 Scope and field of application

1.1 This International Standard specifies a procedure for the determination of the distillation characteristics of motor gasolines, aviation gasolines, aviation turbine fuels, special boiling point spirits, naphthas, white spirit, kerosine, gas oils, distillate fuel oils and similar petroleum products.

NOTE — For the distillation of aviation turbine fuels and other products of such wide boiling range that the low distillation thermometer specified in group 3 of table 1 is inadequate, this method may be applied by substituting the high distillation thermometer, together with the other test conditions specified in group 3 (see 9.3).

1.2 The distillation (volatility) characteristics of petroleum products are indicative of performance in their intended applications. Petroleum product specifications generally include distillation limits to ensure products of suitable volatility performance.

1.3 The empirical results obtained by use of this distillation method have been found to correlate with automotive equipment performance factors and with other characteristics of petroleum products related to volatility.

2 References

ISO 3007, *Petroleum products — Determination of vapour pressure — Reid method.*

ASTM E1, *Specification for ASTM thermometers.*

IP standards for petroleum and its products — Part 1: Methods for analysis and testing (Appendix A).

3 Definitions

3.1 initial boiling point: Temperature noted (corrected if required) at the moment when the first drop of condensate falls from the tip of the condenser during a distillation carried out under standardized conditions.

3.2 end point ; final boiling point: Maximum thermometer reading noted (corrected if required) during the final phase of a distillation carried out under standardized conditions. This usually occurs after the evaporation of all liquid from the bottom of the flask. "Maximum temperature" is a frequently used synonym.

3.3 dry point: Temperature noted (corrected if required) at the moment of vaporization of the last drop of liquid at the bottom of a flask during a distillation carried out under standardized conditions. Any drops or film of liquid on the side of the flask or thermometer are disregarded.

NOTE — The end point (final boiling point), rather than the dry point, is intended for general use. The dry point may be reported in connection with special-purpose naphthas, such as those used in the paint industry. Moreover, it should be substituted for the end point (final boiling point) whenever the sample is of such a nature that the precision of the end point (final boiling point) cannot consistently meet the criteria given in clause 10.

3.4 decomposition point: Thermometer reading which coincides with the first indications of thermal decomposition of the liquid in the flask.

NOTE — Characteristic indications of thermal decomposition are an evolution of fumes and erratic thermometer readings which usually show a decided decrease after any attempt has been made to adjust the heat.

3.5 percent recovered: The volume, in millilitres, of condensate observed in the receiving graduated cylinder in connection with a simultaneous temperature reading.

3.6 percent recovery: The maximum per cent recovered, as observed in accordance with 8.7.

3.7 percent total recovery: The combined percent recovery and residue in the flask, as observed in accordance with 8.7.

3.8 percent loss: 100 minus the percent total recovery.

3.9 percent residue: The percent total recovery minus the percent recovery, or the volume of residue, in millilitres, if measured directly.

3.10 percent evaporated: The sum of the percent recovery and the percent loss.

4 Principle

A 100 ml test portion is distilled under prescribed conditions which are appropriate to the nature of the product (see table 1). Systematic observations of thermometer readings and volumes of condensate are made and the results are calculated from these data.

5 Apparatus

Typical assemblies of the apparatus are shown in figures 2 and 3.

Limited data have been obtained which indicate that certain types of automatic distillation apparatus are capable of giving test results which correspond in level and precision with those obtained by the manual procedures of this method, when the apparatus has been calibrated according to the manufacturer's instructions. When carrying out determinations in accordance with this International Standard, such automatic apparatus shall only be used by agreement between the parties to the test, and provided the type of apparatus is mentioned in the test report.

A condensed summary of these supporting data is given in annex C.

5.1 Distillation flask

Flasks shall be of heat-resistant glass and constructed to the dimensions and tolerances shown in figure 1.

NOTE — For tests specifying dry point, specially selected flasks with bottoms and walls of uniform thickness are desirable.

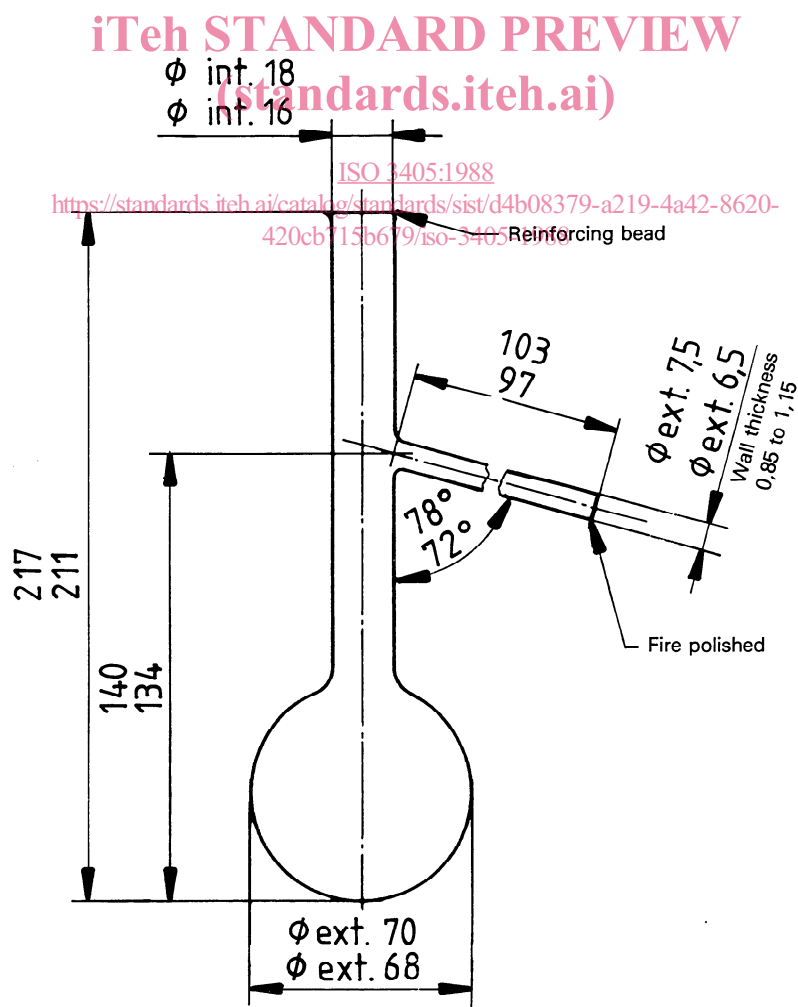

Figure 1 — Distillation flask

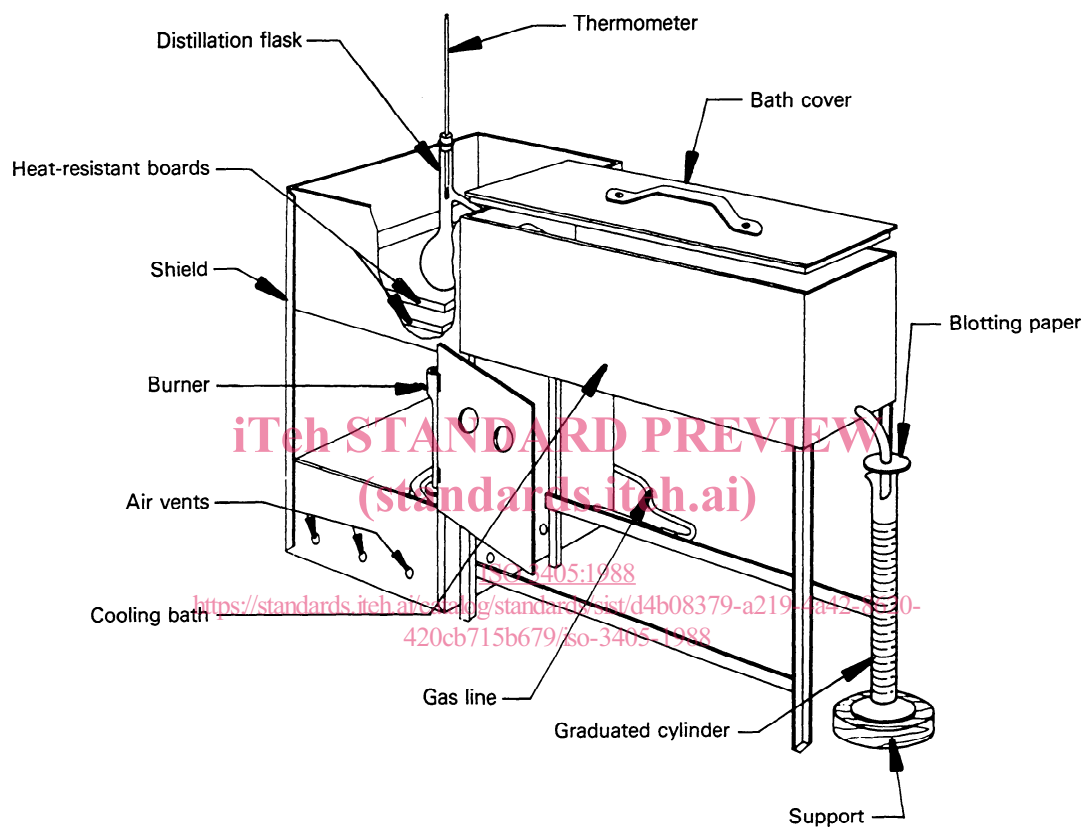
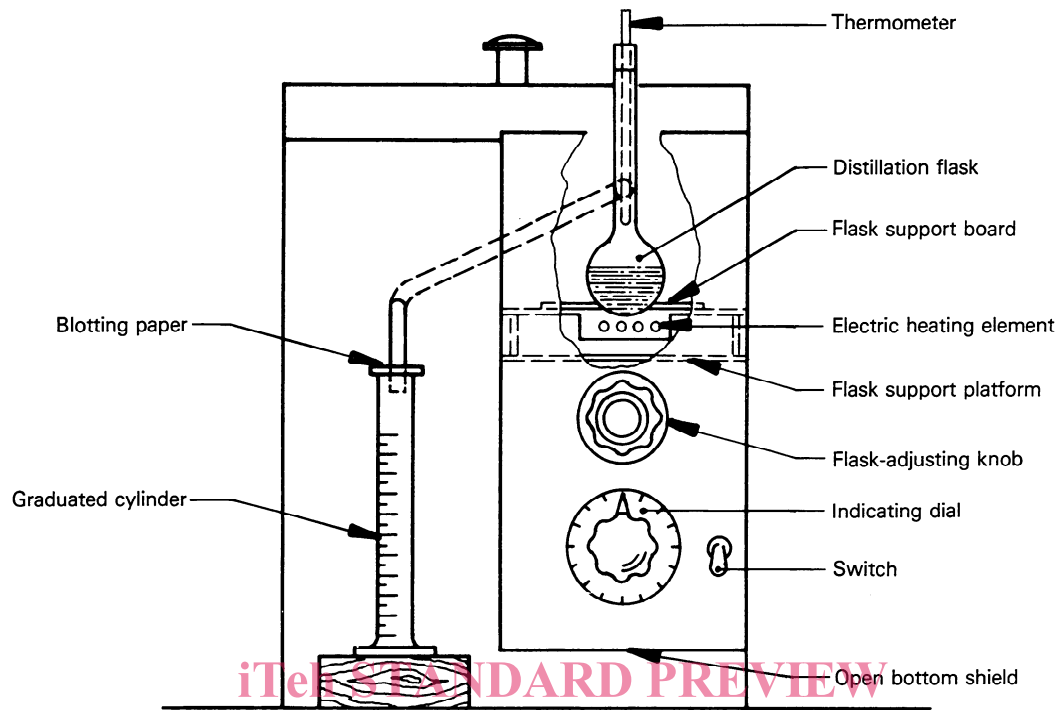

Figure 2 — Apparatus assembly using gas burning



STANDARD PREVIEW
 (standards.iteh.ai)

ISO 3405:1988

<https://standards.iteh.ai/catalog/standards/sist/d4b08379-a219-4a42-8620-420cb715b679/iso-3405-1988>

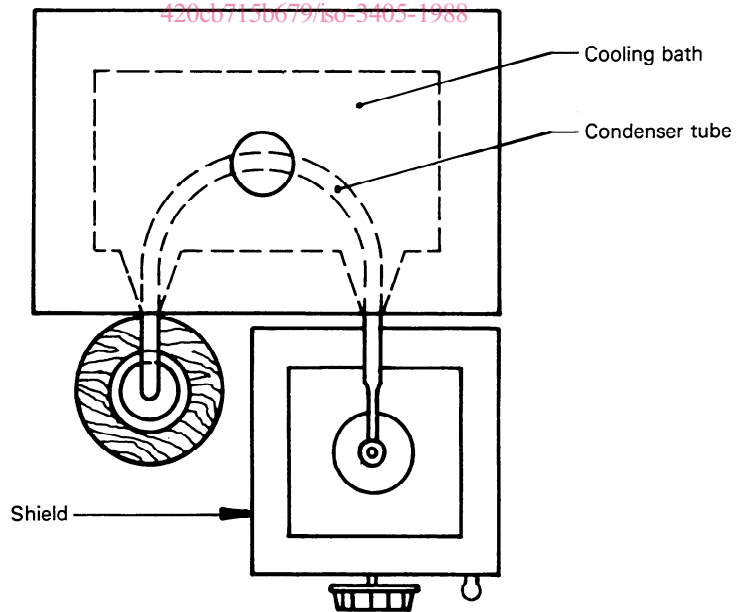

Figure 3 — Apparatus assembly using electric heater

5.2 Condenser and cooling bath

Typical types of condenser and cooling bath are illustrated in figures 2 and 3. Other types of apparatus may be used, provided the test results obtained by their use are such as to satisfy the precision criteria of clause 10.

5.2.1 The condenser shall be made of seamless brass tubing, 560 mm in length. It shall be 14 mm in outside diameter and shall have a wall thickness of 0,8 to 0,9 mm.

5.2.2 The condenser shall be set so that approximately 390 mm of the tube is in contact with the cooling medium, with about 50 mm outside the cooling bath at the upper end, and about 114 mm outside at the lower end. The portion of tube projecting at the upper end shall be set at an angle of 75° to the vertical. The portion of the tube inside the cooling bath may be either straight or bent in any suitable continuous smooth curve. The average gradient shall be 0,26 mm per linear millimetre of condenser tube (equivalent to an angle of 15°), and no section of the immersed portion of the condenser tube shall have a gradient less than 0,24 mm nor more than 0,28 mm per linear millimetre of condenser tube. The projecting lower portion of the condenser tube shall be curved downward for a length of 76 mm and slightly backward so as to ensure contact with the wall of the receiving graduated cylinder at a point approximately 25 to 32 mm below the top of the graduated cylinder when it is in position to receive the distillate. The lower end of the condenser tube shall be cut off at an acute angle so that the tip may be brought into contact with the wall of the graduated cylinder.

5.2.3 The capacity of the cooling bath shall be not less than 5,5 litres of cooling medium. The arrangement of the tube in the cooling bath shall be such that its centreline is not less than 32 mm below the plane of the top of the bath at its point of entrance and not less than 19 mm above the floor of the bath at its exit.

5.2.4 Clearances between the condenser tube and the walls of the bath shall be at least 13 mm except for the sections adjacent to the points of entrance and exit. Multiple tube installations are permissible, provided they conform to the dimensional requirements (see 5.2.2 and 5.2.3) and the capacity of the bath is not less than 5,5 l per tube.

5.3 Metal shield or enclosure for flask

5.3.1 Type 1 shield (see figure 2), 480 mm high, 280 mm long and 200 mm wide, made of sheet metal of approximately 0,8 mm thickness. The shield shall have a door on one narrow side, and two openings 25 mm in diameter equally spaced in each of the two narrow sides, with a slot cut in one side for the upper end of the condenser tube. The centres of these four openings shall be 215 mm below the top of the shield. There shall be three holes of approximately 13 mm in diameter in each of the four sides, with their centres 25 mm above the base of the shield.

5.3.2 Type 2 shield (see figure 3), 440 mm high, 200 mm long and 200 mm wide, made of sheet metal of approximately 0,8 mm thickness and with a window in the front side. The

open bottom of the shield shall be spaced approximately 50 mm from the base of the unit. The rear of the shield shall have an elliptical hole for the upper end of the condenser tube. A flask-adjusting knob shall be located in front of the shield for adjusting the flask support. If an electric heater (see figure 3) is used, it shall be fitted with a stepless heat control unit with an indicating dial. The heater and heat controller shall be built into the lower part of the shield. The remaining portion of the shield above the flask support board (see 5.5.2) shall be the same as the type 1 shield used with the gas burner; the lower portion may be omitted, however, and the heater, control unit and upper part of the shield supported in any convenient manner.

5.4 Heat source

5.4.1 Gas burner (see figure 2), so constructed that sufficient heat from the available gas can be obtained to distill the product at the specified rate. A sensitive regulating valve and gas-pressure governor to give complete control of heating may be provided.

5.4.2 Electric heater (see figure 3): May be used instead of a gas burner, provided it is capable of distilling the product at the specified rate. Heater units of low heat retention, adjustable from 0 to 1 000 W, have been found satisfactory.

5.5 Flask support

5.5.1 Type 1 for use with gas burner (see figure 2)

A ring support of the ordinary laboratory type, 100 mm or larger in diameter, supported on a stand inside the shield, or a platform adjustable from the outside of the shield, may be used.

Two hard boards, made of ceramic or other heat-resistant material, 3 to 6 mm in thickness, shall rest upon the ring or the platform, whichever is used. The board immediately above the ring or platform shall have a central opening 76 to 100 mm in diameter and outside line dimensions slightly smaller than the inside boundaries of the shield.

The second, or flask support, board shall be slightly smaller in outside dimensions than the first board and shall have a central opening conforming to the dimensions in table 1. It shall be 3 to 6 mm in thickness at the centre-hole rim. This flask support board may be moved slightly in accordance with the directions for placing the distillation flask, and direct heat shall be applied to the flask only through the opening in this board.

5.5.2 Type 2 for use with electric heater (see figure 3)

The top of the electric heater shall consist of a hard flask-support board, made of ceramic or other heat-resistant material, with a central opening conforming to the dimensions in table 1. It shall be 3 to 6 mm in thickness at the centre-hole rim. Provision shall be made for moving the heater unit, with its top, so that direct heat is applied to the distillation flask only through the opening in the flask support board.

Table 1 — Test conditions

| | Group 1 | Group 2 | Group 3 | Group 4 |
|--|-----------------------|-----------------------|-----------------------|---|
| Sample characteristics | | | | |
| Vapour pressure at 37,8 °C (ISO 3007) | > 65,5 kPa | < 65,5 kPa | < 65,5 kPa | < 65,5 kPa |
| Distillation : | | | | |
| — initial boiling point ¹⁾ | — | — | < 100 °C | > 100 °C |
| — end point | < 250 °C | < 250 °C | > 250 °C | > 250 °C |
| Preparation of apparatus | | | | |
| Distillation thermometer (see 5.8) | Low temperature range | Low temperature range | Low temperature range | High temperature range |
| Diameter of hole in flask support board ²⁾ | 37,5 mm | 37,5 mm | 50 mm | 50 mm |
| Temperature at start of test : | | | | |
| — flask and thermometer | 13 to 18 °C | 13 to 18 °C | 13 to 18 °C | < ambient |
| — flask support board and shield | < ambient | < ambient | < ambient | — |
| — graduated cylinder and 100 ml charge | 13 to 18 °C | 13 to 18 °C | 13 to 18 °C | 13 °C to ambient |
| Flask size (see 5.1) | 125 ml | 125 ml | 125 ml | 125 ml |
| Conditions during test procedure | | | | |
| Temperature of condenser bath | 0 to 1 °C | 0 to 4 °C | 0 to 4 °C | 0 to 60 °C ³⁾ |
| Temperature of medium around graduated cylinder | 13 to 18 °C | 13 to 18 °C | 13 to 18 °C | within ± 3 °C of temperature of distillation charge |
| Time from first application of heat to initial boiling point | 5 to 10 min | 5 to 10 min | 5 to 10 min | 5 to 15 min |
| Time from initial boiling point to 5 % recovered | 60 to 75 s | 60 to 75 s | — | — |
| Uniform average rate of condensation from 5 % recovered to 5 ml residue in flask | 4 to 5 ml/min | 4 to 5 ml/min | 4 to 5 ml/min | 4 to 5 ml/min |
| Time from 5 ml residue to end point | 3 to 5 min | 3 to 5 min | < 5 min | < 5 min |

1) As determined under all test conditions of the group concerned.

2) Hole diameters are to be reviewed.

3) The proper condenser bath temperature will depend upon the wax content of the sample and of its distillation fractions. The minimum temperature which permits satisfactory operation should be used.

5.6 Graduated cylinder

The graduated cylinder shall have a capacity of 100 ml and be graduated at intervals of 1 ml. The shape of the base is optional but it shall be such that the receiver does not topple when placed empty on a surface inclined at an angle of 15° to the horizontal.

Construction details and tolerances for the graduated cylinder are shown in figure 4. The use of a Crow receiver is permitted provided that the vertical dimension and the scale length are as shown in the figure.

5.7 Cooling bath for cylinder

An optional cooling bath (see second paragraph of 7.7), such as a tall-form beaker of clear glass or transparent plastic, of sufficient height to allow the graduated cylinder to be immersed up to the 100 ml graduation line in a cooling liquid.

5.8 Thermometer¹⁾

The thermometer shall be of the mercury-in-glass type, nitrogen filled, graduated on the stem and enamel backed, and shall conform to the specifications given in table 2.

1) Thermometers ASTM 7C and 8C, and IP 5C and 6C, are suitable (see clause 2).

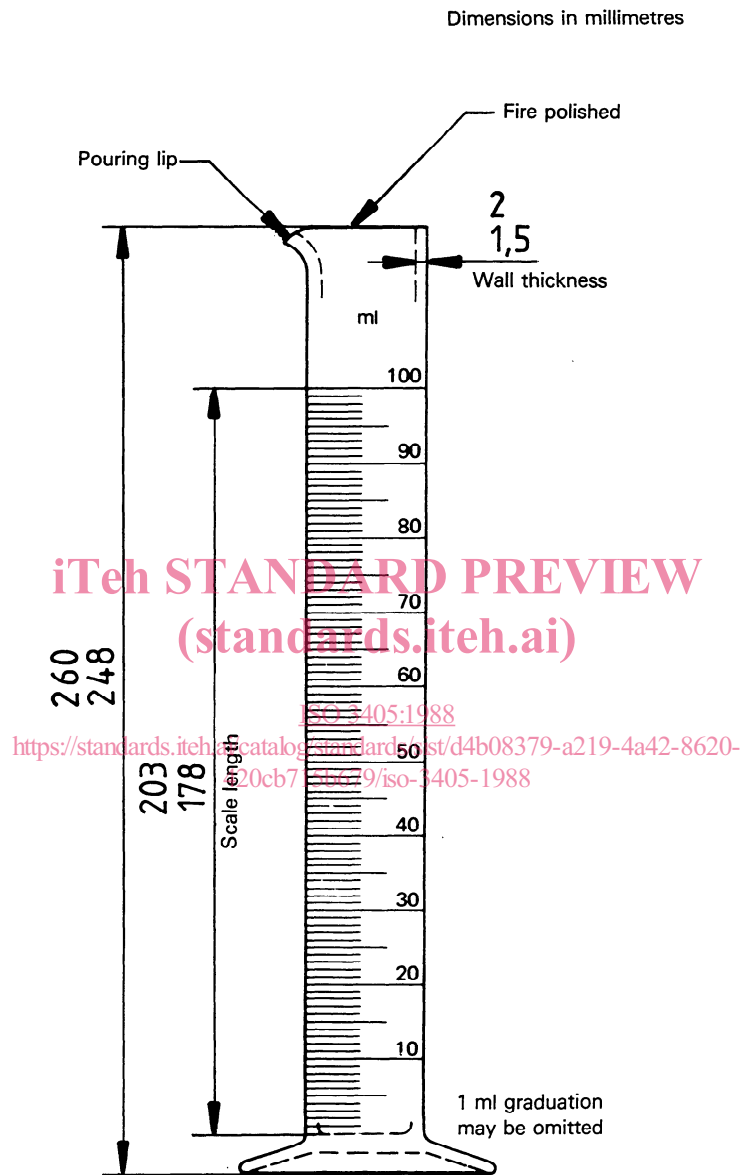

Figure 4 – Graduated cylinder
 (100 ml in 1 ml graduations, tolerance $\pm 1,0$ ml)

Table 2 — Thermometer specifications

| | Low temperature range | High temperature range |
|---|------------------------|-----------------------------|
| Range | −2 to +300 °C | −2 to +400 °C ¹⁾ |
| Sub-divisions | 1 °C | 1 °C |
| Immersion | total | total |
| Overall length | 381 to 391 mm | 381 to 391 mm |
| Stem diameter | 6 to 7 mm | 6 to 7 mm |
| Bulb shape | cylindrical | cylindrical |
| Bulb length | 10 to 15 mm | 10 to 15 mm |
| Bulb diameter | 5 to 6 mm | 5 to 6 mm |
| Distance from bottom of bulb to 0 °C line | 100 to 110 mm | 25 to 45 mm |
| Distance from bottom of bulb to 300 °C line | 333 to 354 mm | — |
| Distance from bottom of bulb to 400 °C line | — | 333 to 354 mm |
| Longer lines at each | 5 °C | 5 °C |
| Figured at each | 10 °C | 10 °C |
| Scale error, max. | 0,5 °C, up to 300 °C | 1,0 °C, up to 370 °C |
| Maximum line width | 0,23 mm | 0,23 mm |
| Expansion chamber | required ²⁾ | — |
| Heat stability | see note | see note |

1) Under certain test conditions, the bulb of the thermometer may be 28 °C above the temperature indicated by the thermometer, and at an indicated temperature of 371 °C the temperature of the bulb is approaching a critical range in the glass. If a thermometer is used at an indicated temperature above 371 °C it should not be re-used without checking the ice point.

2) An expansion chamber is provided for relief of gas pressure to avoid distortion of the bulb at higher temperatures. It is not for the purpose of joining mercury separations. Under no circumstances should the thermometer be heated above the highest temperature reading.

<https://standards.iteh.ai/catalog/standards/sist/d4b08379-a219-4a42-8620-420cb715b679/iso-3405-1988>

Thermometers shall be artificially aged by means of a suitable heat treatment before graduation in order to secure stability of zero. This treatment shall be such that, after the procedure described below, the maximum error is within the limits specified.

Heat the thermometer to a temperature corresponding to its highest scale line and keep it at this temperature for 5 min. Allow the thermometer to cool, either naturally in still air, or slowly in the test bath at a reproducible rate to 20 °C above ambient temperature or to 50 °C, whichever is the lower, then determine the error at a selected reference point. If natural cooling in air is used, the error shall be determined within 1 h. Heat the thermometer again to a temperature equal to its highest scale line and keep it at this temperature for 24 h, allow it to cool to one of the two temperatures referred to above, at the same rate as in the first part of the test, and redetermine the error under the same conditions as before.

6 Sampling

6.1 In the case of a product having a Reid vapour pressure of 65,5 kPa or higher, cool the sample bottle to a temperature between 13 and 18 °C. Collect the sample in the previously cooled bottle, preferably by immersing the bottle in the liquid, where possible, and discarding the first filling. Where immersion is not possible, draw off the sample into the previously cooled bottle in such a manner that agitation is kept to a

minimum. Close the bottle immediately with a tight-fitting stopper, and place it in an ice bath or refrigerator capable of maintaining the sample at a temperature not exceeding 15 °C.

6.2 Samples of materials that visibly contain water are not suitable for testing. If the sample is not dry, and the expected initial boiling point is below 66 °C, obtain for the test another sample which is free from suspended water. If the expected initial boiling point is above 66 °C, shake the sample with anhydrous sodium sulfate or another suitable drying agent and separate it from the drying agent by decanting.

7 Preparation of apparatus

7.1 Refer to table 1 and select the thermometer which is required for the sample to be tested. Bring the respective temperatures of the flask, thermometer, graduated cylinder, flask support and shield to their required values for starting the test.

7.2 Fill the condenser box to cover the condenser tube with any non-flammable coolant such as chopped ice, water, brine or ethylene glycol solution which is suitable for the temperature specified in table 1. If chopped ice is used, add sufficient water to cover the condenser tube. If necessary, make suitable provision, such as circulation, stirring or air blowing, so as to maintain the required condenser bath temperature throughout the test. Similarly, make any necessary provision so that the temperature of the bath around the graduated cylinder will remain within the limits specified in table 1.

7.3 Remove any residual liquid in the condenser tube by swabbing with a piece of soft, lint-free cloth attached to a cord or copper wire.

7.4 Bring the temperature of the sample to within the range prescribed in table 1. Measure 100 ml of the sample in the graduated cylinder and transfer it as completely as practicable to the distillation flask, taking care that none of the liquid flows into the vapour tube.

7.5 Fit the thermometer, provided with a snugly fitting, well rolled cork, tightly into the neck of the flask so that the bulb is centred in the neck and the lower end of the capillary is level with the highest point on the bottom of the inner wall of the vapour tube (see figure 5).

7.6 Place the flask containing the charge in its support and make a tight connection with the condenser tube by means of a cork through which the vapour tube has been passed. Adjust the flask so that it is in a vertical position and so that the vapour tube extends into the condenser tube for a distance of 25 to 50 mm.

7.7 Place the graduated cylinder that was used to measure the charge, without drying, into its bath under the lower end of the condenser tube so that the end of the condenser tube is centred in the graduated cylinder and extends into it for a distance of at least 25 mm but not below the 100 ml mark. Cover the graduated cylinder closely with a piece of blotting paper, or similar material, suitably weighted, which has been cut to fit the condenser tube snugly. Maintain the level of the bath around the graduated cylinder so that it is at least as high as the 100 ml mark.

If the temperature of the air surrounding the cylinder does not meet the requirements of table 1, a cooling bath (5.7) shall be used and the cylinder immersed so that the liquid covers the 100 ml graduation line.

7.8 Record the prevailing barometric pressure, and proceed at once with the distillation, as specified in clause 8.

8 Procedure

8.1 Apply heat to the distillation flask and its contents. Regulate the heating at this stage so that the time interval between the first application of heat and the initial boiling point is within the limits prescribed in table 1.

8.2 Immediately after observing the initial boiling point, move the graduated cylinder so that the tip of the condenser touches its inner wall. Continue to regulate the heating so that the rate of condensation into the graduated cylinder is uniform and within the limits prescribed in table 1. Repeat any distillation which does not meet the conditions prescribed in table 1.

8.3 In the interval between the initial boiling point and the end of the distillation, observe and record whatever data are necessary for the calculation and reporting of the results of the test as prescribed in clause 9. These observed data may include thermometer readings at prescribed percentages recovered, or percentages recovered at prescribed thermometer readings, or both. Record all volumes in the graduated cylinder to the nearest 0,5 ml and all thermometer readings to the nearest 0,5 °C.

8.4 If a decomposition point is observed, discontinue the heating and proceed as directed in 8.7. Otherwise, proceed as directed in 8.5.

8.5 When the volume of residual liquid in the flask is approximately 5 ml, make a final adjustment of the heat, if necessary, so that the time from the 5 ml of liquid residue in the flask to the end point (final boiling point) meets the requirement given in table 1. If this condition is not satisfied, repeat the test, with appropriate modification of the final heat adjustment.

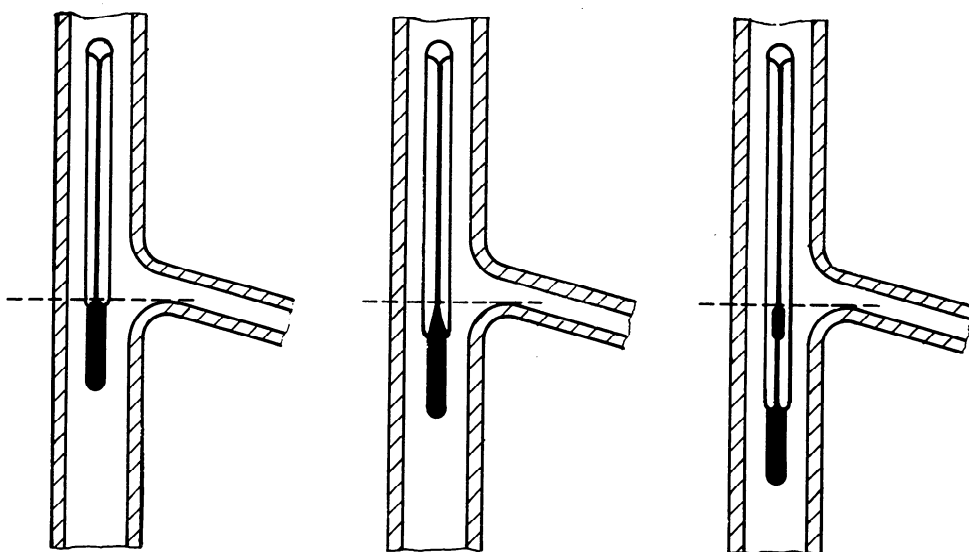

Figure 5 — Position of thermometer in distillation flask