



SLOVENSKI STANDARD
SIST ISO 3405:1996

01-marec-1996

Naftni proizvodi - Določanje destilacijskih lastnosti

Petroleum products -- Determination of distillation characteristics

Produits pétroliers -- Détermination des caractéristiques de distillation

Ta slovenski standard je istoveten z: ISO 3405:1988

[SIST ISO 3405:1996](https://standards.iteh.ai/catalog/standards/sist/a1d5d03-e702-4c05-a580-8b72ffac5d97/sist-iso-3405-1996)

<https://standards.iteh.ai/catalog/standards/sist/a1d5d03-e702-4c05-a580-8b72ffac5d97/sist-iso-3405-1996>

ICS:

75.080	Naftni proizvodi na splošno	Petroleum products in general
--------	-----------------------------	-------------------------------

SIST ISO 3405:1996

en

iTeh STANDARD PREVIEW
(standards.iteh.ai)

[SIST ISO 3405:1996](#)

<https://standards.iteh.ai/catalog/standards/sist/af1d5d03-e702-4c05-a580-8b72ffac5d97/sist-iso-3405-1996>

INTERNATIONAL STANDARD

ISO
3405

Second edition
1988-12-01



INTERNATIONAL ORGANIZATION FOR STANDARDIZATION
ORGANISATION INTERNATIONALE DE NORMALISATION
МЕЖДУНАРОДНАЯ ОРГАНИЗАЦИЯ ПО СТАНДАРТИЗАЦИИ

Petroleum products — Determination of distillation characteristics

Produits pétroliers — Détermination des caractéristiques de distillation

ITC STANDARD PREVIEW
(standards.iteh.ai)

[SIST ISO 3405:1996](https://standards.iteh.ai/catalog/standards/sist/af1d5d03-e702-4c05-a580-8b72ffac5d97/sist-iso-3405-1996)

<https://standards.iteh.ai/catalog/standards/sist/af1d5d03-e702-4c05-a580-8b72ffac5d97/sist-iso-3405-1996>

ISO 3405 : 1988 (E)

Foreword

ISO (the International Organization for Standardization) is a worldwide federation of national standards bodies (ISO member bodies). The work of preparing International Standards is normally carried out through ISO technical committees. Each member body interested in a subject for which a technical committee has been established has the right to be represented on that committee. International organizations, governmental and non-governmental, in liaison with ISO, also take part in the work. ISO collaborates closely with the International Electrotechnical Commission (IEC) on all matters of electrotechnical standardization.

Draft International Standards adopted by the technical committees are circulated to the member bodies for approval before their acceptance as International Standards by the ISO Council. They are approved in accordance with ISO procedures requiring at least 75 % approval by the member bodies voting.

International Standard ISO 3405 was prepared by Technical Committee ISO/TC 28, *Petroleum products and lubricants*.

[SIST ISO 3405:1996](https://standards.iteh.ai/catalog/standards/sist/af1d5d03-e702-4c05-a580-86721ac5d77/sist-iso-3405-1996)

This second edition cancels and replaces the first edition (ISO 3405 : 1975), of which it constitutes a technical revision.

Users should note that all International Standards undergo revision from time to time and that any reference made herein to any other International Standard implies its latest edition, unless otherwise stated.

Petroleum products — Determination of distillation characteristics

1 Scope and field of application

1.1 This International Standard specifies a procedure for the determination of the distillation characteristics of motor gasolines, aviation gasolines, aviation turbine fuels, special boiling point spirits, naphthas, white spirit, kerosine, gas oils, distillate fuel oils and similar petroleum products.

NOTE — For the distillation of aviation turbine fuels and other products of such wide boiling range that the low distillation thermometer specified in group 3 of table 1 is inadequate, this method may be applied by substituting the high distillation thermometer, together with the other test conditions specified in group 3 (see 9.3).

1.2 The distillation (volatility) characteristics of petroleum products are indicative of performance in their intended applications. Petroleum product specifications generally include distillation limits to ensure products of suitable volatility performance.

1.3 The empirical results obtained by use of this distillation method have been found to correlate with automotive equipment performance factors and with other characteristics of petroleum products related to volatility.

2 References

ISO 3007, *Petroleum products — Determination of vapour pressure — Reid method.*

ASTM E1, *Specification for ASTM thermometers.*

IP standards for petroleum and its products — Part 1: Methods for analysis and testing (Appendix A).

3 Definitions

3.1 initial boiling point: Temperature noted (corrected if required) at the moment when the first drop of condensate falls from the tip of the condenser during a distillation carried out under standardized conditions.

3.2 end point ; final boiling point: Maximum thermometer reading noted (corrected if required) during the final phase of a distillation carried out under standardized conditions. This usually occurs after the evaporation of all liquid from the bottom of the flask. "Maximum temperature" is a frequently used synonym.

3.3 dry point: Temperature noted (corrected if required) at the moment of vaporization of the last drop of liquid at the bottom of a flask during a distillation carried out under standardized conditions. Any drops or film of liquid on the side of the flask or thermometer are disregarded.

NOTE — The end point (final boiling point), rather than the dry point, is intended for general use. The dry point may be reported in connection with special-purpose naphthas, such as those used in the paint industry. Moreover, it should be substituted for the end point (final boiling point) whenever the sample is of such a nature that the precision of the end point (final boiling point) cannot consistently meet the criteria given in clause 10.

3.4 decomposition point: Thermometer reading which coincides with the first indications of thermal decomposition of the liquid in the flask.

NOTE — Characteristic indications of thermal decomposition are an evolution of fumes and erratic thermometer readings which usually show a decided decrease after any attempt has been made to adjust the heat.

3.5 percent recovered: The volume, in millilitres, of condensate observed in the receiving graduated cylinder in connection with a simultaneous temperature reading.

3.6 percent recovery: The maximum per cent recovered, as observed in accordance with 8.7.

3.7 percent total recovery: The combined percent recovery and residue in the flask, as observed in accordance with 8.7.

3.8 percent loss: 100 minus the percent total recovery.

ISO 3405 : 1988 (E)

3.9 percent residue: The percent total recovery minus the percent recovery, or the volume of residue, in millilitres, if measured directly.

3.10 percent evaporated: The sum of the percent recovery and the percent loss.

4 Principle

A 100 ml test portion is distilled under prescribed conditions which are appropriate to the nature of the product (see table 1). Systematic observations of thermometer readings and volumes of condensate are made and the results are calculated from these data.

5 Apparatus

Typical assemblies of the apparatus are shown in figures 2 and 3.

Limited data have been obtained which indicate that certain types of automatic distillation apparatus are capable of giving test results which correspond in level and precision with those obtained by the manual procedures of this method, when the apparatus has been calibrated according to the manufacturer's instructions. When carrying out determinations in accordance with this International Standard, such automatic apparatus shall only be used by agreement between the parties to the test, and provided the type of apparatus is mentioned in the test report.

A condensed summary of these supporting data is given in annex C.

5.1 Distillation flask

Flasks shall be of heat-resistant glass and constructed to the dimensions and tolerances shown in figure 1.

NOTE — For tests specifying dry point, specially selected flasks with bottoms and walls of uniform thickness are desirable.

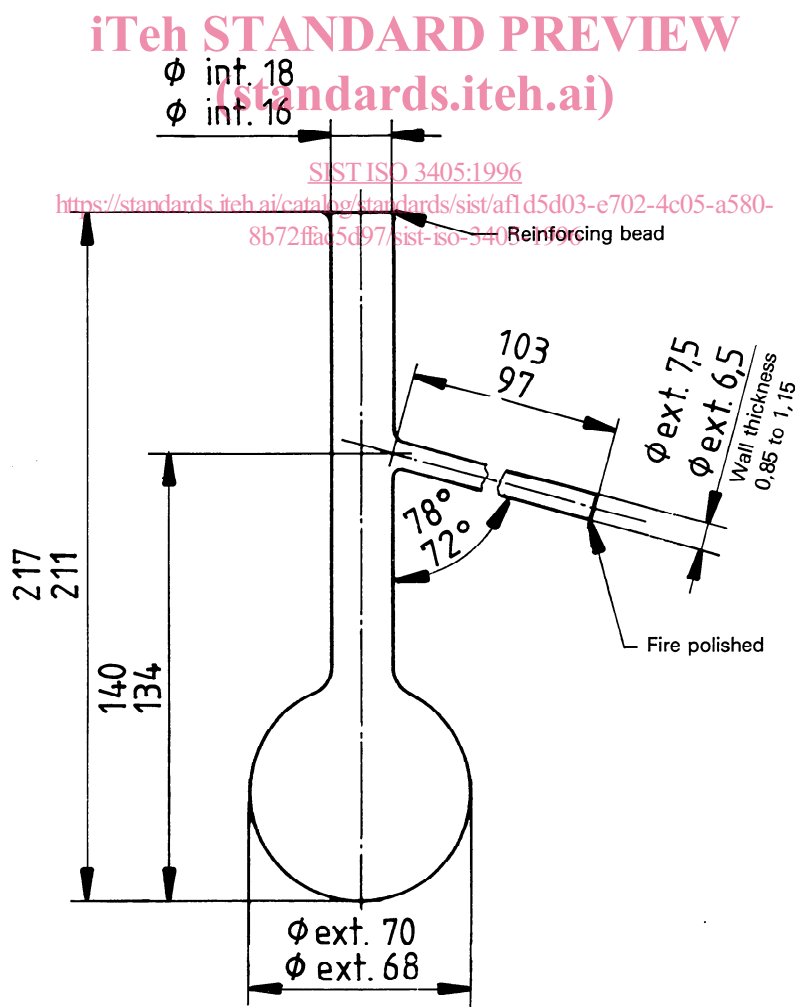

Figure 1 — Distillation flask

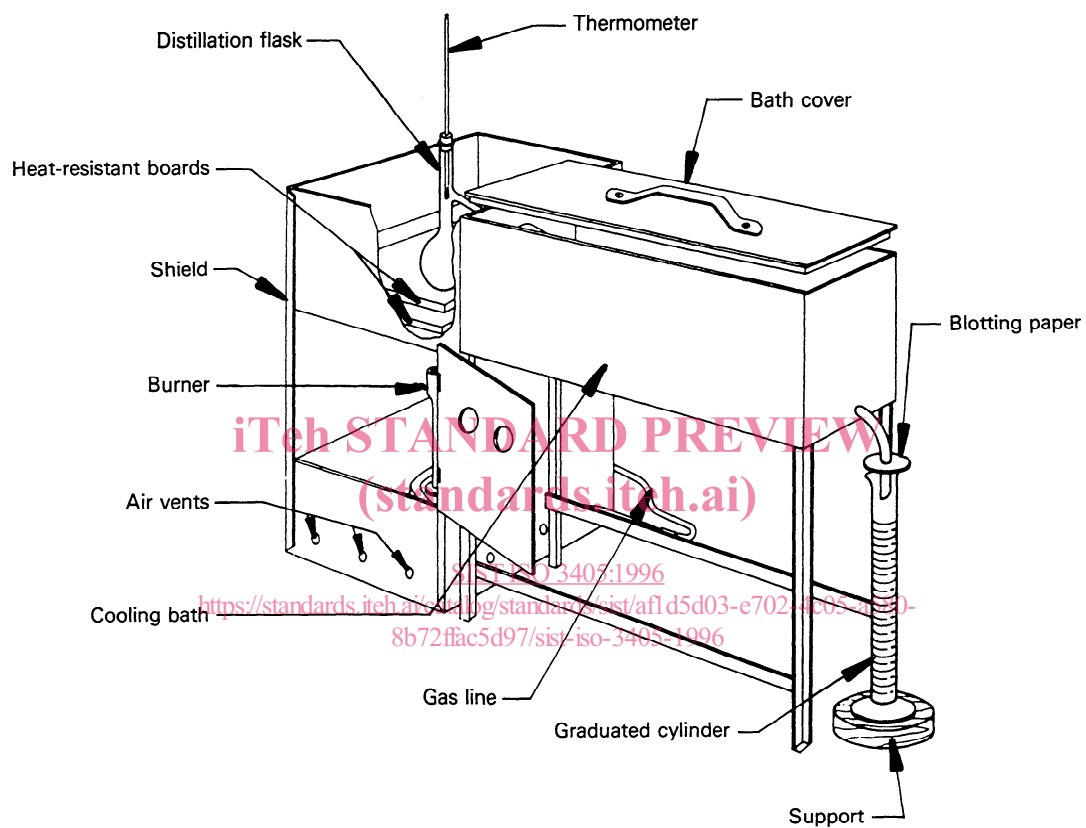
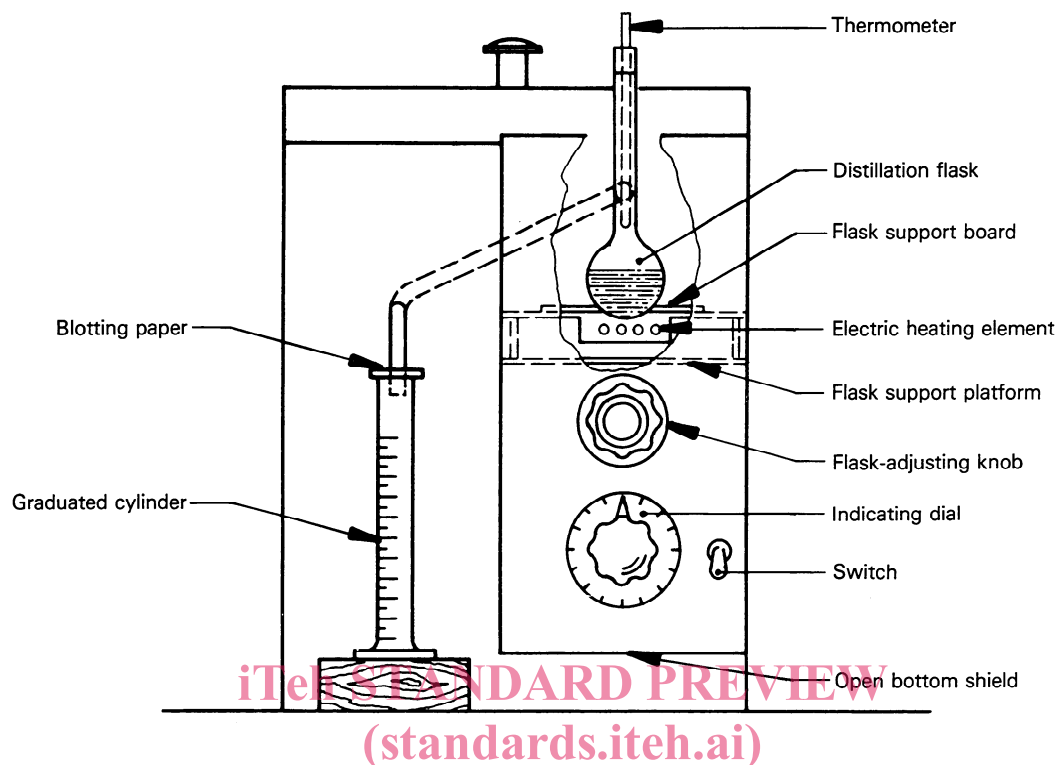

Figure 2 — Apparatus assembly using gas burning



SIST ISO 3405:1996

<https://standards.iteh.ai/catalog/standards/sist/afl d5d03-e702-4c05-a580-8b72ffac5d97/sist-iso-3405-1996>

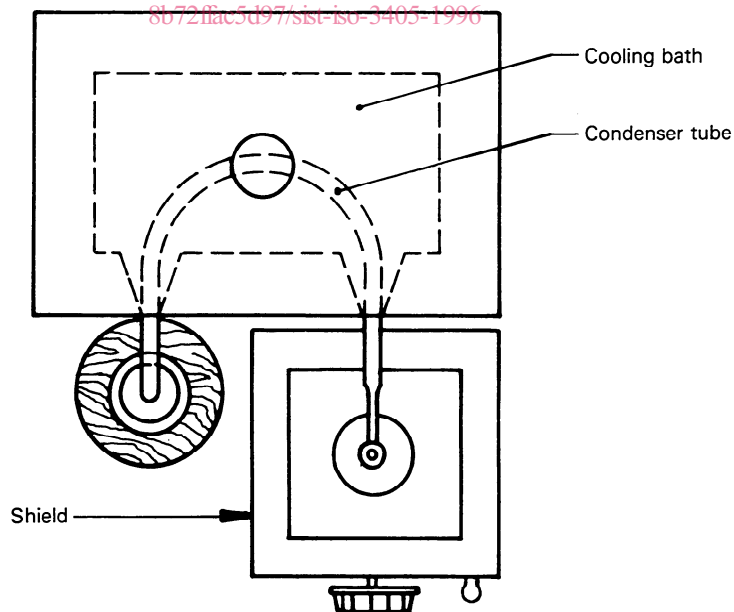

Figure 3 — Apparatus assembly using electric heater

5.2 Condenser and cooling bath

Typical types of condenser and cooling bath are illustrated in figures 2 and 3. Other types of apparatus may be used, provided the test results obtained by their use are such as to satisfy the precision criteria of clause 10.

5.2.1 The condenser shall be made of seamless brass tubing, 560 mm in length. It shall be 14 mm in outside diameter and shall have a wall thickness of 0,8 to 0,9 mm.

5.2.2 The condenser shall be set so that approximately 390 mm of the tube is in contact with the cooling medium, with about 50 mm outside the cooling bath at the upper end, and about 114 mm outside at the lower end. The portion of tube projecting at the upper end shall be set at an angle of 75° to the vertical. The portion of the tube inside the cooling bath may be either straight or bent in any suitable continuous smooth curve. The average gradient shall be 0,26 mm per linear millimetre of condenser tube (equivalent to an angle of 15°), and no section of the immersed portion of the condenser tube shall have a gradient less than 0,24 mm nor more than 0,28 mm per linear millimetre of condenser tube. The projecting lower portion of the condenser tube shall be curved downward for a length of 76 mm and slightly backward so as to ensure contact with the wall of the receiving graduated cylinder at a point approximately 25 to 32 mm below the top of the graduated cylinder when it is in position to receive the distillate. The lower end of the condenser tube shall be cut off at an acute angle so that the tip may be brought into contact with the wall of the graduated cylinder.

5.2.3 The capacity of the cooling bath shall be not less than 5,5 litres of cooling medium. The arrangement of the tube in the cooling bath shall be such that its centreline is not less than 32 mm below the plane of the top of the bath at its point of entrance and not less than 19 mm above the floor of the bath at its exit.

5.2.4 Clearances between the condenser tube and the walls of the bath shall be at least 13 mm except for the sections adjacent to the points of entrance and exit. Multiple tube installations are permissible, provided they conform to the dimensional requirements (see 5.2.2 and 5.2.3) and the capacity of the bath is not less than 5,5 l per tube.

5.3 Metal shield or enclosure for flask

5.3.1 Type 1 shield (see figure 2), 480 mm high, 280 mm long and 200 mm wide, made of sheet metal of approximately 0,8 mm thickness. The shield shall have a door on one narrow side, and two openings 25 mm in diameter equally spaced in each of the two narrow sides, with a slot cut in one side for the upper end of the condenser tube. The centres of these four openings shall be 215 mm below the top of the shield. There shall be three holes of approximately 13 mm in diameter in each of the four sides, with their centres 25 mm above the base of the shield.

5.3.2 Type 2 shield (see figure 3), 440 mm high, 200 mm long and 200 mm wide, made of sheet metal of approximately 0,8 mm thickness and with a window in the front side. The

open bottom of the shield shall be spaced approximately 50 mm from the base of the unit. The rear of the shield shall have an elliptical hole for the upper end of the condenser tube. A flask-adjusting knob shall be located in front of the shield for adjusting the flask support. If an electric heater (see figure 3) is used, it shall be fitted with a stepless heat control unit with an indicating dial. The heater and heat controller shall be built into the lower part of the shield. The remaining portion of the shield above the flask support board (see 5.5.2) shall be the same as the type 1 shield used with the gas burner; the lower portion may be omitted, however, and the heater, control unit and upper part of the shield supported in any convenient manner.

5.4 Heat source

5.4.1 Gas burner (see figure 2), so constructed that sufficient heat from the available gas can be obtained to distill the product at the specified rate. A sensitive regulating valve and gas-pressure governor to give complete control of heating may be provided.

5.4.2 Electric heater (see figure 3): May be used instead of a gas burner, provided it is capable of distilling the product at the specified rate. Heater units of low heat retention, adjustable from 0 to 1 000 W, have been found satisfactory.

5.5 Flask support

5.5.1 Type 1 for use with gas burner (see figure 2)

A ring support of the ordinary laboratory type, 100 mm or larger in diameter, supported on a stand inside the shield, or a platform adjustable from the outside of the shield, may be used.

Two hard boards, made of ceramic or other heat-resistant material, 3 to 6 mm in thickness, shall rest upon the ring or the platform, whichever is used. The board immediately above the ring or platform shall have a central opening 76 to 100 mm in diameter and outside line dimensions slightly smaller than the inside boundaries of the shield.

The second, or flask support, board shall be slightly smaller in outside dimensions than the first board and shall have a central opening conforming to the dimensions in table 1. It shall be 3 to 6 mm in thickness at the centre-hole rim. This flask support board may be moved slightly in accordance with the directions for placing the distillation flask, and direct heat shall be applied to the flask only through the opening in this board.

5.5.2 Type 2 for use with electric heater (see figure 3)

The top of the electric heater shall consist of a hard flask-support board, made of ceramic or other heat-resistant material, with a central opening conforming to the dimensions in table 1. It shall be 3 to 6 mm in thickness at the centre-hole rim. Provision shall be made for moving the heater unit, with its top, so that direct heat is applied to the distillation flask only through the opening in the flask support board.

Table 1 — Test conditions

	Group 1	Group 2	Group 3	Group 4
Sample characteristics				
Vapour pressure at 37,8 °C (ISO 3007)	> 65,5 kPa	< 65,5 kPa	< 65,5 kPa	< 65,5 kPa
Distillation :				
— initial boiling point ¹⁾	—	—	< 100 °C	> 100 °C
— end point	< 250 °C	< 250 °C	> 250 °C	> 250 °C
Preparation of apparatus				
Distillation thermometer (see 5.8)	Low temperature range	Low temperature range	Low temperature range	High temperature range
Diameter of hole in flask support board ²⁾	37,5 mm	37,5 mm	50 mm	50 mm
Temperature at start of test :				
— flask and thermometer	13 to 18 °C	13 to 18 °C	13 to 18 °C	< ambient
— flask support board and shield	< ambient	< ambient	< ambient	—
— graduated cylinder and 100 ml charge	13 to 18 °C	13 to 18 °C	13 to 18 °C	13 °C to ambient
Flask size (see 5.1)	125 ml	125 ml	125 ml	125 ml
Conditions during test procedure				
Temperature of condenser bath	0 to 1 °C	0 to 4 °C	0 to 4 °C	0 to 60 °C ³⁾
Temperature of medium around graduated cylinder	13 to 18 °C	13 to 18 °C	13 to 18 °C	within ± 3 °C of temperature of distillation charge
Time from first application of heat to initial boiling point	5 to 10 min	5 to 10 min	5 to 10 min	5 to 15 min
Time from initial boiling point to 5 % recovered	60 to 75 s	60 to 75 s	—	—
Uniform average rate of condensation from 5 % recovered to 5 ml residue in flask	4 to 5 ml/min	4 to 5 ml/min	4 to 5 ml/min	4 to 5 ml/min
Time from 5 ml residue to end point	3 to 5 min	3 to 5 min	< 5 min	< 5 min

1) As determined under all test conditions of the group concerned.

2) Hole diameters are to be reviewed.

3) The proper condenser bath temperature will depend upon the wax content of the sample and of its distillation fractions. The minimum temperature which permits satisfactory operation should be used.

5.6 Graduated cylinder

The graduated cylinder shall have a capacity of 100 ml and be graduated at intervals of 1 ml. The shape of the base is optional but it shall be such that the receiver does not topple when placed empty on a surface inclined at an angle of 15° to the horizontal.

Construction details and tolerances for the graduated cylinder are shown in figure 4. The use of a Crow receiver is permitted provided that the vertical dimension and the scale length are as shown in the figure.

5.7 Cooling bath for cylinder

An optional cooling bath (see second paragraph of 7.7), such as a tall-form beaker of clear glass or transparent plastic, of sufficient height to allow the graduated cylinder to be immersed up to the 100 ml graduation line in a cooling liquid.

5.8 Thermometer¹⁾

The thermometer shall be of the mercury-in-glass type, nitrogen filled, graduated on the stem and enamel backed, and shall conform to the specifications given in table 2.

1) Thermometers ASTM 7C and 8C, and IP 5C and 6C, are suitable (see clause 2).

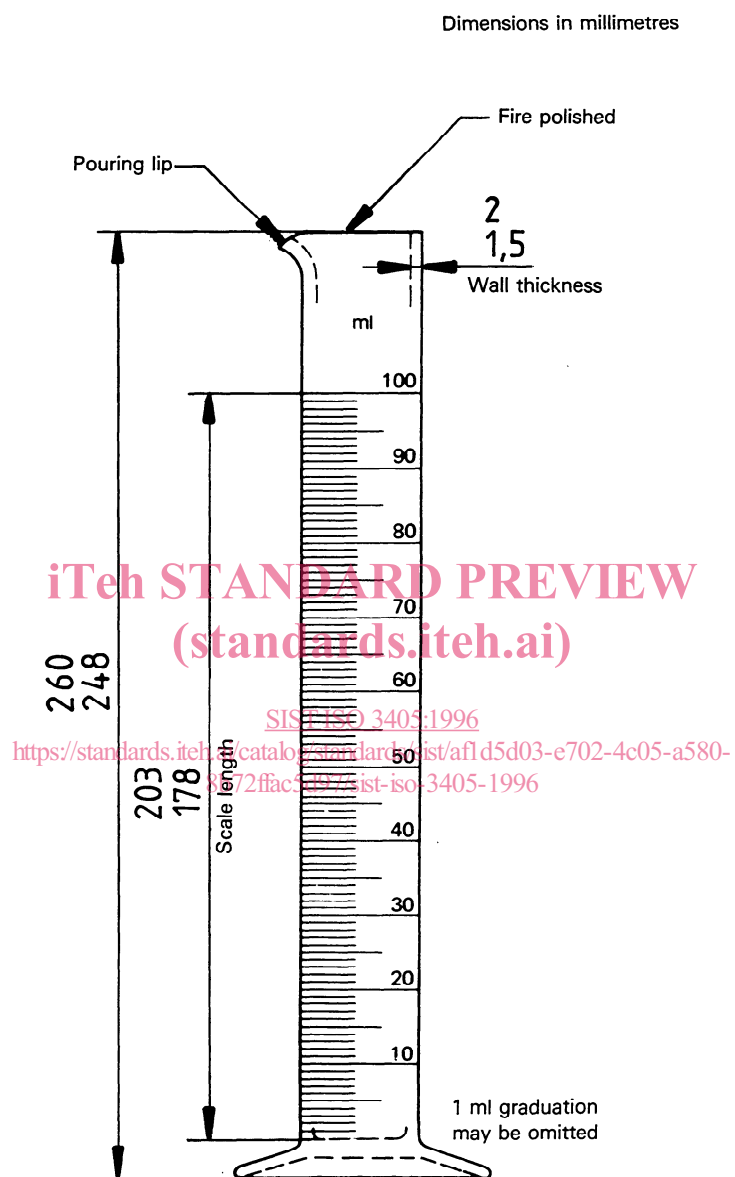

Figure 4 – Graduated cylinder
(100 ml in 1 ml graduations, tolerance $\pm 1,0$ ml)