



Designation: **F1774 – 99 (Reapproved 2005) F1774 – 13**

Standard Specification for Climbing and Mountaineering Carabiners¹

This standard is issued under the fixed designation F1774; the number immediately following the designation indicates the year of original adoption or, in the case of revision, the year of last revision. A number in parentheses indicates the year of last reapproval. A superscript epsilon (ϵ) indicates an editorial change since the last revision or reapproval.

1. Scope

1.1 This specification covers six mechanical tests and the minimum performance requirements for carabiners designed specifically for the sports of climbing and mountaineering.

1.2 Two different types of carabiners are defined in this standard, non-locking carabiners and locking carabiners.

1.3 Tests contained herein are destructive in nature. Carabiners subjected to any of these tests shall not be used in any way after testing except in evaluating the results of such testing.

1.4 This specification does not imply approval of any method of use of climbing and mountaineering carabiners. In addition, the test load values contained herein are not to be interpreted as the forces which a climbing and mountaineering carabiner may be subjected to, or expected to sustain in actual field use.

1.5 This specification is limited to carabiners made of steel or aluminum alloys only.

1.6 The values stated in SI units are to be regarded as the standard.

2. Referenced Documents

2.1 *ASTM Standards:*²

[E4 Practices for Force Verification of Testing Machines](#)

[F1772 Specification for Harnesses for Rescue, Safety, and Sport Activities](#)

[F1775 Specification for Labeling of Climbing and Mountaineering Equipment](#) (Withdrawn 2009)³

2.2 *Other Standard:*

[EN 566:1994 Slings](#) [preliminary]

3. Terminology

3.1 *Definitions*—Terms defined in Terminology [F1772](#) shall be applicable to this specification.

3.2 *Definitions of Terms Specific to This Standard:*

3.2.1 *carabiner, n*—a self-closing gated, load-bearing, connective device. Some carabiner models may have *cocking* or *blocking* devices, that when activated, override the self-closing features.

3.2.2 *durably affixed, adj*—the manner of attaching information directly to the product which endures for the life of the product.

3.2.3 *failure, n*—an arbitrary point beyond which a material or product ceases to be functionally capable of its intended use. In this application, the point at which some part of the carabiner physically breaks or distorts to an extent that the test members are released.

3.2.4 *locking carabiner, n*—a carabiner with a mechanism that reduces the possibility of a gate being opened inadvertently. A locking mechanism requires at least two different consecutive manual actions to open the gate.

3.2.5 *nonlocking carabiner, n*—any carabiner that does not have a mechanism that reduces the possibility of a gate being opened inadvertently.

3.2.6 *normal body weight, n*—a standardized weight that represents a *typical* climber, defined as Function Test Force No. 1.

3.2.7 *ultimate strength, n*—the maximum force sustained by a carabiner during an ultimate force test, prior to its failure.

¹ This specification is under the jurisdiction of ASTM Committee [F32](#) on Search and Rescue and is the direct responsibility of Subcommittee [F32.01](#) on Equipment, Testing, and Maintenance.

Current edition approved Oct. 1, 2005 Dec. 15, 2013. Published October 2005 February 2014. Originally approved in 1997. Last previous edition approved in 1999 2005 as [F1774 – 99](#); [F1774 – 99](#) (2005). DOI: [10.1520/F1774-99R05](#); [10.1520/F1774-13](#).

² For referenced ASTM standards, visit the ASTM website, [www.astm.org](#), or contact ASTM Customer Service at [service@astm.org](#). For *Annual Book of ASTM Standards* volume information, refer to the standard's Document Summary page on the ASTM website.

4. Requirements

4.1 *Product information shall include the following items:*

4.1.1 *Manufacturer's or Distributor's Name or Logo*—A clear indication as to who is responsible for the primary manufacture or distribution, or both, of the product.

4.1.2 *Major Axis Gate Closed Ultimate Strength*—A clear indication as to the major axis gate closed strength by either symbol or pictorial representation.

4.1.3 *Minor Axis Gate Closed Ultimate Strength*—A clear indication as to the minor axis gate closed ultimate strength by either symbol or pictorial representation.

4.1.4 *Major Axis Gate Open Ultimate Strength*—A clear indication as to the major axis gate open ultimate strength by either symbol or pictorial representation.

4.1.5 *Lot Number*—A manufacturer's or distributor's lot number.

4.1.6 Either symbol or pictorial representation to read the manufacturer's or distributor's instructions.

4.2 Lettering, symbols, and pictorial representations shall be durably affixed to the carabiner.

4.3 Lettering, symbols, and pictorial representations shall be a minimum of 2 mm ($\frac{5}{64}$ in.) in height.

5. Significance and Use

5.1 *Gate Function During Body Weight Test*—This test simulates a climber's body weight of Function Test Force No. 1 and verifies that the gate functions as intended under body weight force.

5.2 *Major Axis Gate Closed 70 % Force Test*—This test verifies that the gate functions as originally intended after Function Test Force No. 2 has been applied and released.

5.3 *Locking Mechanism Test*—This test verifies that the locking mechanism keeps the gate in the locked position between forces of 0 kN and Function Force Test No. 3.

5.4 *Major Axis Gate Closed Ultimate Strength Test*—This test is intended to show the force required to physically fail the carabiner.

5.5 *Major Axis Gate Open Ultimate Strength Test*—This test simulates a potential inadvertent use of a carabiner. It is intended to show the force required to physically fail the carabiner.

5.6 *Minor Axis Gate Closed Ultimate Strength Test*—This test simulates a potential inadvertent use of a carabiner. It is intended to show the force required to fail physically the carabiner along the minor axis.

6. Responsibility for Quality Assurance

6.1 Quality control is solely the responsibility of the manufacturer or purchaser, or both, and is not addressed by this specification.

7. Apparatus and Condition

7.1 *Tensile Tester*, capable of calibration in accordance with Practices E4 to the ultimate strength of all carabiners tested.

7.2 *Test Fixtures and Supplies:*

7.2.1 There are four total test pins required, two pins with 6 ± 0.05 -mm radius and two pins with 5 ± 0.05 -mm radius. Pins must be alloy steel and heat-treated to minimum Rockwell hardness, C scale 60. The mean surface roughness, R_a , must not exceed $0.8 \mu\text{m}$ and the peak to valley height, R_{max} , must not exceed $6.3 \mu\text{m}$. The fixture should be designed in such a way that the pins do not rotate and that the carabiner is free to locate itself on the pins when the force is applied. See Figs. 1 and 2.

7.2.2 *Molybdenum-Based Grease.*

7.3 *Test Conditions*—The ambient temperature shall be between 15 and 23°C.

8. Hazards

8.1 Carabiners may disengage or eject parts from the test fixture. Use a safety screen and wear safety glasses while testing. Do not perform this test alone.

9. Sampling

9.1 *Number of Tests*—The number of samples for testing will be specified by the manufacturer's quality assurance program. A minimum of five will be used, in sequence, for the gate function during body weight, major axis gate closed 70 %, and major axis gate closed ultimate strength tests. A minimum of five will be used for the major axis gate open ultimate strength test. A minimum of five will be used for the minor axis gate closed ultimate strength test.

10. Performance Specifications

10.1 *Gate Function During Body Weight Test:*

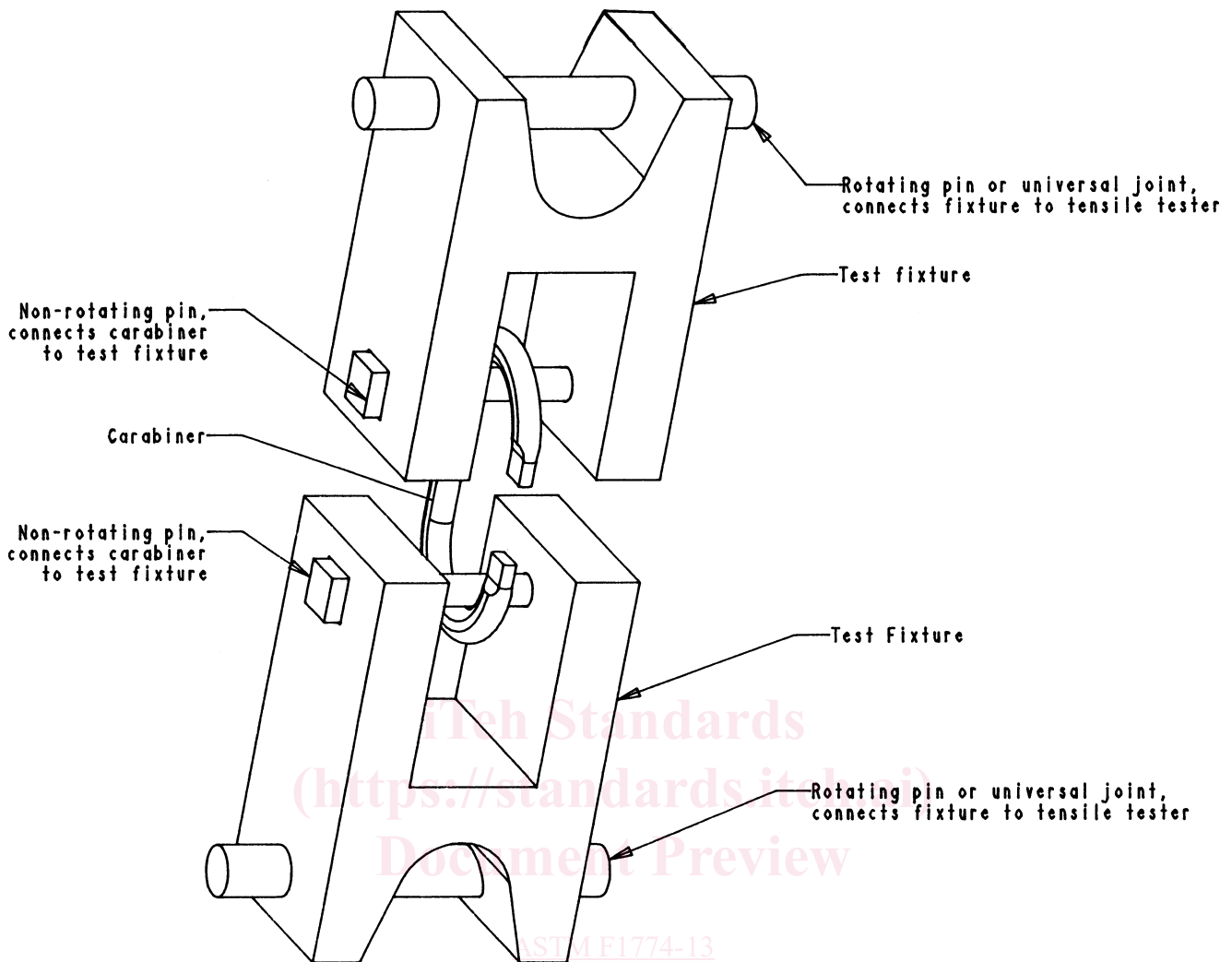

FIG. 1 Major Axis Test Set-Up

10.1.1 Function Test Force No. 1 will be used for this test. Each of the carabiners subjected to the body weight test shall show no evidence of distortion that impairs the designed function.

10.1.2 While the body weight force is applied, the carabiner gate shall open and close as designed and with the same quality and performance as before the test.

10.1.3 When a locking carabiner is locked while the body weight force is applied, the locking mechanism must be able to be rotated to its unlocked position by hand after the force is removed.

10.2 *Major Axis Gate Closed 70 Force Test*—Function Test Force No. 2 will be used for this test. Each of the carabiners subjected to the 70 % force test shall show no evidence of distortion that impairs the designed function after the test is conducted. The locking mechanism of a locking carabiner shall open and close as originally intended and with the same quality and performance as before the test.

10.3 *Locking Mechanism Test*—Function Test Force No. 3 will be used for this test. With the locking mechanism in the locked position and an inward force of 50 N applied to the center of the gate, the gate must not open as Function Test Force No. 3 is applied to the major axis of the carabiner. When the load is released, the gate and locking mechanism must be fully functional.

10.4 *Major Axis Gate Closed Ultimate Strength Test:*

10.4.1 Each of the nonlocking carabiners subjected to this test shall have an ultimate strength equal to or greater than the major axis gate closed minimum ultimate strength for nonlocking carabiners listed in [Table 1](#).

10.4.2 Each of the locking carabiners subjected to this test shall have an ultimate strength equal to or greater than the major axis gate closed minimum ultimate strength for locking carabiners listed in [Table 1](#).

10.5 *Major Axis Gate Open Ultimate Strength Test:*

10.5.1 Each of the nonlocking carabiners subjected to this test shall have an ultimate strength equal to or greater than the major axis gate open minimum ultimate strength for nonlocking carabiners listed in [Table 1](#).