



Designation: F476 – 84 (Reapproved 2002)

Standard Test Methods for Security of Swinging Door Assemblies¹

This standard is issued under the fixed designation F476; the number immediately following the designation indicates the year of original adoption or, in the case of revision, the year of last revision. A number in parentheses indicates the year of last reapproval. A superscript epsilon (ϵ) indicates an editorial change since the last revision or reapproval.

This standard has been approved for use by agencies of the Department of Defense.

1. Scope

1.1 These test methods cover door assemblies of various materials and types of construction for use in wall openings to deter unwanted intruders.

1.2 Door assemblies, covered by these test methods, also include individual components such as the hinge, lock, door, jamb/strike, and jamb/wall.

1.3 These test methods are designed to measure the capability of a swinging door assembly to restrain or delay and to frustrate the commission of “break-in” crimes.

1.4 These test methods apply primarily to typical entry door assemblies in single- and multi-family residential housing.

1.5 *This standard does not purport to address all of the safety concerns, if any, associated with its use. It is the responsibility of the user of this standard to establish appropriate safety and health practices and determine the applicability of regulatory limitations prior to use.*

2. Referenced Documents

2.1 *ASTM Standards:*²

F471 Terminology Relating to Combination Locks

3. Terminology Definitions

3.1 *bolt*—a metal bar which, when actuated, is projected (or thrown) either horizontally or vertically into a retaining member, such as a strike plate, to impede a door from moving or opening.

3.2 *bolt projection (or bolt throw)*—the distance from the edge of the door, at the bolt center line, to the farthest point on the bolt in the projected position, when subjected to end pressure.

3.3 *component*—as distinguished from a part, a subassembly that combines with other components to make up a total door assembly. The prime components of a door assembly include: door, lock, hinges, jamb/wall, jamb/strike, and wall.

3.4 *cylinder*—the cylindrical subassembly of a lock, containing the cylinder core, tumbler mechanism, and the keyway. A double-cylinder lock is one which has a key-actuated cylinder on both the exterior and interior of the door.

3.5 *cylinder core (or cylinder plug)*—the central part of a cylinder, containing the keyway, which is rotated by the key to operate the lock mechanism.

3.6 *deadbolt*—a lock bolt that does not have a spring action as opposed to a latch bolt that does. The bolt must be actuated by a key or a knob, or both, or thumb turn, and when projected becomes locked against return by end pressure.

3.7 *dead latch (or dead locking latch bolt)*—a spring-actuated latch bolt having a beveled end and incorporating a plunger which, when depressed, automatically locks the projected latch bolt against return by end pressure.

3.8 *door assembly*—a unit composed of a group of parts or components that make up a closure for a passageway through a wall. For the purposes of these test methods, a door assembly consists of the following parts: door, hinges, locking device or devices, operation contacts (such as handles, knobs, push plates), miscellaneous hardware and closures, the frame, including the head and jambs plus the anchorage devices to the surrounding wall, and a portion of the surrounding wall extending 900 mm (36 in.) from each side of the jambs and 400 mm (16 in.) above the head.

3.9 *jamb*—the vertical members of a door frame (such as, those fixed members to which the door is secured).

3.10 *jamb/strike*—that component of a door assembly which receives and holds securely the extended lock bolt. The strike and jamb, used together, are considered a unit.

3.11 *jamb/wall*—that component of a door assembly to which a door is attached and secured. The wall and jamb, used together, are considered a unit.

3.12 *key-in-knob*—a lockset having the key cylinder and other lock mechanisms, such as a push or turn button, contained in the knobs.

¹ This method is under the jurisdiction of ASTM Committee F12 on Security Systems and Equipment and is the direct responsibility of Subcommittee F12.50 on Locking Devices.

Current edition approved March 10, 2002. Published July 1984. Originally published as F476 – 76. Last previous edition F476 – 76. DOI: 10.1520/F0476-84R02.

² For referenced ASTM standards, visit the ASTM website, www.astm.org, or contact ASTM Customer Service at service@astm.org. For *Annual Book of ASTM Standards* volume information, refer to the standard's Document Summary page on the ASTM website.

3.13 *latch (or latch bolt)*—a beveled, spring-actuated bolt, that may or may not have a dead locking device.

3.14 *lock (or lockset)*—a keyed device (complete with cylinder, latch or dead bolt mechanism, and trim such as knobs, levers, thumb turns, escutcheons, etc.) for securing a door in a closed position against forced entry. For the purposes of this standard, a lock does not include the strike plate.

3.15 *lock front*—the outer plate through which the locking bolt projects and which is usually flush with the edge of the door.

3.16 *part*—as distinguished from component, a unit (or subassembly) that combines with other units to make up a component.

3.17 *strike*—a metal plate attached to, or mortised into a door jamb to receive and to hold a projected latch bolt or dead bolt, or both, in order to secure the door to the jamb.

3.18 *swinging door*—a stile (side)-hinged door.

3.19 *Type A lock*—a lock that uses a single bolt, or separate latch and lock bolts that are mechanically interconnected.

3.20 *Type B lock*—a lock in which the latch bolt is mechanically independent from the lock bolt.

3.21 For definitions of other terms used in these test methods, refer to Terminology **F471**.

4. Significance and Use

4.1 Crime statistics show that the majority of all burglary attacks are on residential property. These test methods are, therefore, designed to aid in identifying a level of physical restraint, by swinging door assemblies, that will help reduce this large increment of crime.

4.2 These test methods are not intended to provide a measure of resistance for a door assembly subjected to attacks by skilled burglars on high pay-off targets. These attacks and targets require higher level, more sophisticated resistance, which usually includes alarms, communication, and apprehension systems.

4.3 The wall assembly described in 7.3 is considered suitable for the scope of these test methods. Wall construction that differs in dynamic response from that described in 6.3 may require testing in accordance with Section 11.

4.4 The primary purpose of this standard is to provide detailed test methods. Acceptance criteria for performance levels are considered a matter for authorities having jurisdiction. Some potential guidelines may be found in Annex A1.

5. Apparatus

5.1 A detailed description of test equipment suitable for this standard can be found in **Appendix X1**. In summary, the equipment consists of the following:

5.1.1 *Door Ram*—The door ram shall be a pendulum system with a steel weight capable of delivering horizontal impacts of up to 200 J (148 ft·lbf). The striking end of the weight shall be hemispherical and have a diameter of approximately 150 mm (6 in.).

5.1.2 *Component Ram*—The component ram shall be a pendulum system with a steel weight capable of delivering horizontal impacts of up to 100 J (74 ft·lbf). The striking end of the weight shall have an impact nose approximately 32 mm (1¼ in.) in diameter.

5.1.3 *Vertical Impactor*—The vertical pendulum system shall employ a steel weight and be capable of delivering vertical (downward) impacts of up to 100 J (74 ft·lbf) to a door knob installed in a door assembly.

5.1.4 *Torque Applicator*—The portable torque applicator shall be capable of delivering and measuring up to 160 N·m (118 lbf·ft) of torque to both door knobs and lock cylinders. The torque loading adapters shall be designed to grip the knobs and cylinders.

5.1.5 *Tension Loading Device*—The tension loading device shall be capable of delivering and measuring tensile forces of up to 18 kN (4000 lbf).

5.1.6 *Compression Loading Device*—The compression loading device shall be capable of delivering and measuring compressive forces of up to 900 N (200 lbf).

5.1.7 *Jamb Spreading Device*—The jamb spreading device shall be capable of delivering to door jambs and measuring spreading forces of up to 22 kN (4950 lbf) with a means of measuring up to 13 mm (½ in.) of increase in lock-front to strike distance. The device shall have on each end either a load bearing plate or pressure foot that provides a minimum contact surface of 40 by 120 mm (1½ by 5 in.).

5.1.8 *Instrument Accuracy*—The tension loading and jamb spreading devices shall have a combined calibration and reading error no greater than 200 N (45 lbf). The compression loading device shall have a combined calibration and reading error of no greater than 40 N (9 lbf). The torquemeter shall have a combined error no greater than 3.4 N·m (2.5 lbf·ft). The impact energy of each pendulum system shall be controlled to within ± 1 %.

6. Construction and Size

6.1 The construction and size of the test door assemblies, consisting of single doors, doors in pairs, special-purpose doors (such as Dutch doors), jambs and headers, and all hardware components shall be representative of the classification or rating that is desired.

6.2 The door assembly support fixture shall simulate the rigidity normally provided to a door assembly in a building by the ceiling, floor and walls. **Fig. 1** shows an acceptable fixture.

6.3 The test fixture for door, door jamb, hinge, lock, strike, and other components shall consist of a vertical wall section constructed from 2 by 4 wood studs, 410 mm (16 in.) on center, with a rough entry door opening, and shall be covered with 13-mm (½-in.) exterior grade plywood sheathing on the exterior and ½-in. gypsum board on the interior. It shall be constructed as shown in **Fig. 2** and shall be secured to the wall support fixture (at the sides and top) and to the laboratory floor. For tests of door, lock, strike, and hinge components, the fixture wall section shall also include a door jamb.

6.4 The alternative test fixture for lockset components shall consist of a small door assembly, as shown in **Figs. 3 and 4**. The frame shall be fabricated from steel angle and plate at least 5 mm (¾ in.) thick. The test panel shall be 600 mm (24 in.) square and 45 mm (1¾ in.) thick, made by bonding three pieces of plywood together or by cutting a section from a 45-mm (1¾-in.) solid wood core door (such as, glued block core construction NWMA IS-1). A50 by 50 by 3-mm (2 by 2 by ⅛-in.) steel angle shall be bolted to the hinge edge of the

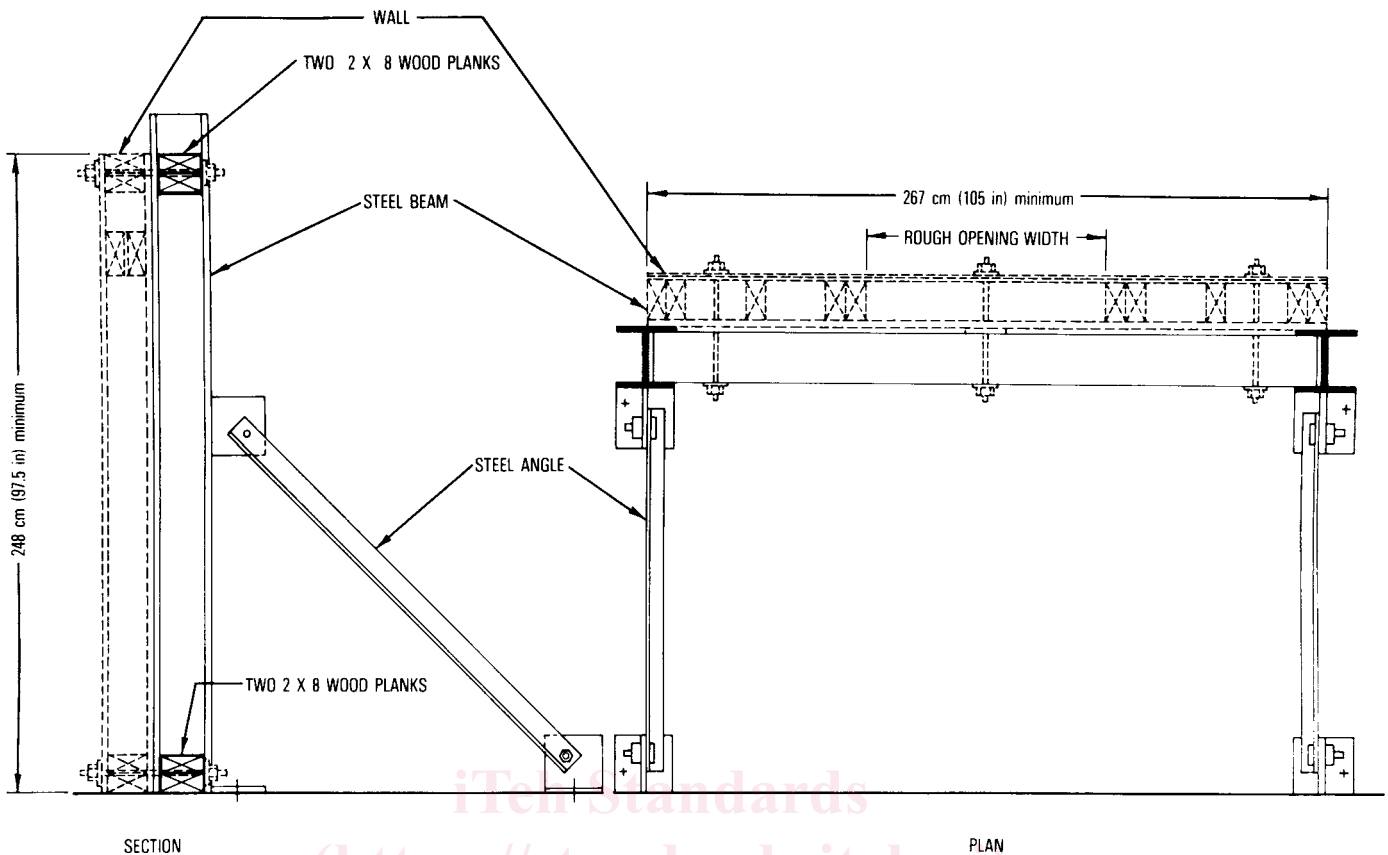

- NOTE 1—Vertical members are equivalent to, or better in bending than, W8 × 10 steel beam.
 NOTE 2—Horizontal members are equivalent to, or better in bending than, a 2 by 8-ft wood plank.
 NOTE 3—Diagonal members are equivalent to, or better than, 2 by 2 by ¼ in.-steel angle.
 NOTE 4—Adequate floor anchorage of the entire wall support fixture is essential.

FIG. 1 Wall Support Fixture

door panel, and a removable steel strike plate shall be bolted to the frame at the lock position of the door panel. The alternate lockset component test fixture shown in Figs. 3 and 4 may be used in lieu of the lockset component test fixture shown. The use of steel plates and expendable wood blocks as shown in the drawing may be used on the full size test fixture as described in 6.3 when testing lock and hinge components.

6.5 The test fixture for static bolt load tests (10.2) shall consist of a vertical panel fabricated from wood attached to a stable horizontal base, as shown in Fig. 5. The top edge of the panel shall be parallel to the bottom surface of the base. The panel shall be about 45 mm (1¾ in.) thick and the top edge shall be prepared to permit the lock set which is being tested to be mounted in the panel in accordance with the manufacturer's instructions.

7. Sampling

7.1 Specimens shall be representative and adequately identified for future reference. Complete manufacturer or fabricator

installation instructions and full-size templates for all items of hardware shall be included.

8. Mounting for Test

8.1 Swinging doors shall be mounted so as to open away from the working area, except when testing an out-swinging door assembly.

8.2 Prepare doors and door jambs for the installation of locksets and hinges in conformance with the manufacturer's instructions. Follow the manufacturer's instructions for fastening the jamb to the support fixture described in 6.2.

8.3 Install components such as test doors, door jambs, hinges, and jamb/strikes in the component test fixture described in 6.3. Except when testing hinges, hinge the door with 1½ pairs of 115-mm (4½-in.) steel butt hinges, and fix it in the closed-locked position (at the normal lock point) with a real or simulated latch bolt having sufficient strength and stiffness to prevent it from failing during test. In the absence of other construction specifications, make the clearances on the lock

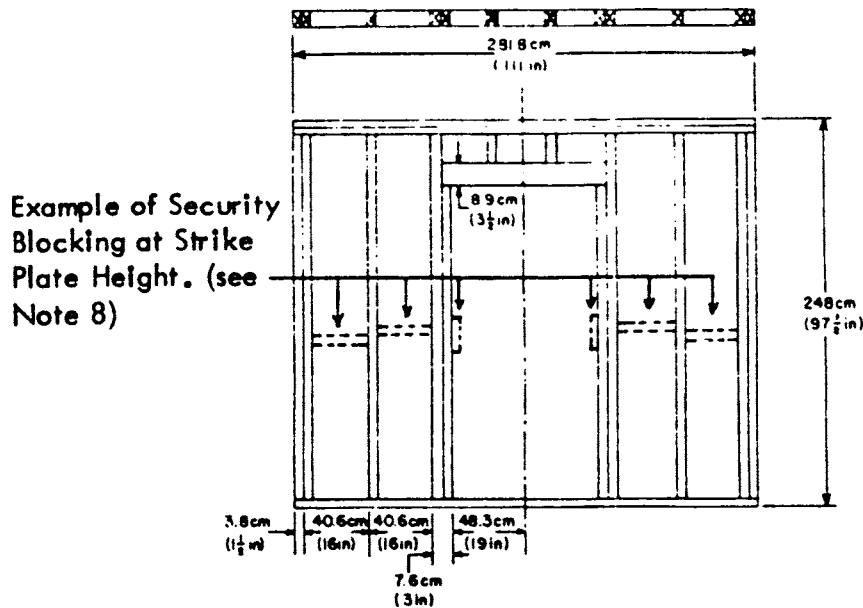

Example of Security Blocking at Strike Plate Height. (see Note 8)

NOTE 1—All studs, plates and headers are 2-by-4s.

NOTE 2—Nail sole plate and lower member of top plate to each stud with 2—16d end nails.

NOTE 3—Nail upper member of top plate to the lower member with 16d nails, one nail near each stud and two near each end.

NOTE 4—Nail the double studs together with 16d nails not more than 610 mm (24 in.) on centers.

NOTE 5—Nail the header (two 2-by-4s) to each full length stud with 4—16d end nails.

NOTE 6—Nail 1/2 in. plywood sheathing to plates and studs with 6d nails at 150 mm (6 in.) on centers around the perimeter and at 300 mm (12 in.) on centers along intermediate supports.

NOTE 7—Nail 1/2-in. gypsum drywall to all supports with threaded drywall nails at 200 mm (8 in.) on centers.

NOTE 8—Security blocking may be necessary to achieve successful jamb/wall stiffness test results. If blocking is used, it shall be reported in the test report. The nature of the blocking shall be indicated.

FIG. 2 Door, Door Jamb, Hinge, and Lock Strike Component Fixture

side, hinge side, and top of the door 3.2 ± 0.4 mm ($1/8 \pm 1/64$ in.). Clearance at the threshold is not considered critical in these tests.

8.4 To test locksets as components, install them in the alternative component test fixture described in 6.4. Fix the test panel in the closed locked position at the normal locking point. Hinge the test panel with two 115-mm (4 1/2-in.) steel butt hinges.

8.5 To test lock sets for static bolt load, install them in the test fixture described in 6.5.

9. Procedure

9.1 One complete assembly shall be used to conduct the tests. Tests shall be given in the sequence of Sections 10-21. Tests under Sections 10, 12, 13, 14, 15, and 16, if conducted in the test panel shall not be repeated in the door assembly being tested. These tests need not be repeated for successive tests of other door assemblies where the same lock model is being used.

10. Static Bolt Load Test

10.1 To test Type A and B locks and all door assembly locks, mount the lock in the test fixture described in 6.5. Lock the door lock with the dead bolt or dead latch in the fully projected position. If the lock incorporates a dead-latch plunger, attach a 6.5-mm (1/4-in.) spacer to the lock front. Allow the dead-latch plunger to project flush with the top of the

spacer, and hold it in that position with a piece of tape, or by another suitable means.

10.2 Place the lock, in the test fixture, in a compression testing machine, or mount it on a firm, level surface with the compression loading device directly above it with the loading face parallel to the lock front, and the axis of the hydraulic ram perpendicular to the lock front. Apply an increasing compressive load to the end of the latch bolt or the dead bolt. Note the maximum force required to depress the latch bolt or the dead bolt to where the farthest point on the bolt is 6 mm (1/4 in.) from the lock front surface.

10.3 To test for bolt projection, apply end pressure to the projected dead bolt or dead latch and measure the distance from the lock front surface to the farthest point on the bolt or latch at the center line.

10.3.1 Following the test of a lock incorporating a dead latch, place the strike plate provided with the lock over the latch of a dead latch to determine whether it is possible for both the dead latch and the dead plunger to enter the hold in the strike simultaneously.

11. Jamb/Wall Stiffness Test

11.1 Prepare the test specimen in accordance with 8.3. Position the jamb spreading device (5.1.7) between the door jambs, at lock height. Apply increasing force as required and measure the space between the lock front and strike.

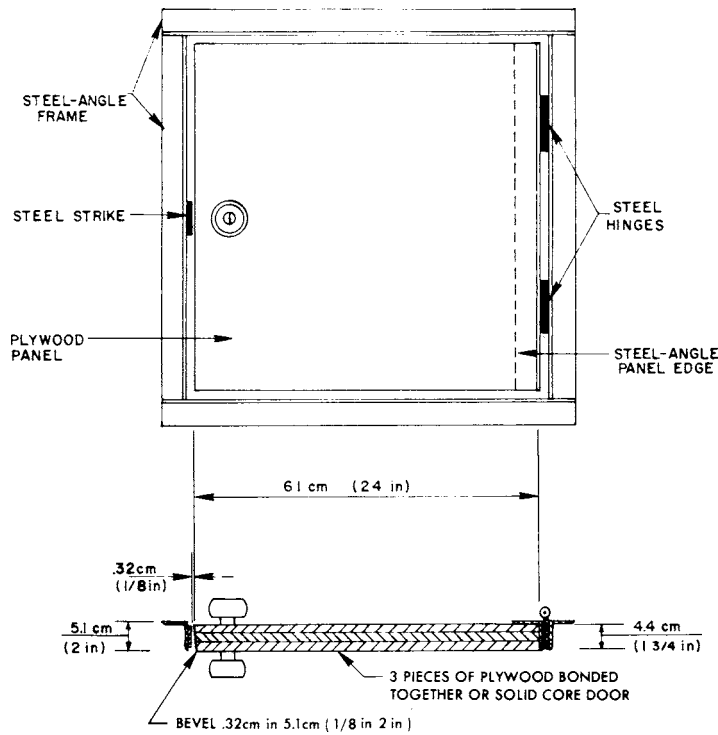

NOTE 1—The door panel consists of three pieces of plywood [610 mm (24 in.) square] bonded together (1 piece, 19 mm (3/4 in.) thick, between two pieces, each 13 mm (1/2 in.) thick); or a glued block core door with premium or good grade hardwood veneer (NWMA I.S. 1-74).

NOTE 2—The door panel shall have a steel angle bolted to the hinge edge.

NOTE 3—The steel angle frame and panel edge shall be 51 by 51 by 3 mm (2 by 2 by 1/8 in.) thick.

FIG. 3 Lockset Component Test Fixture

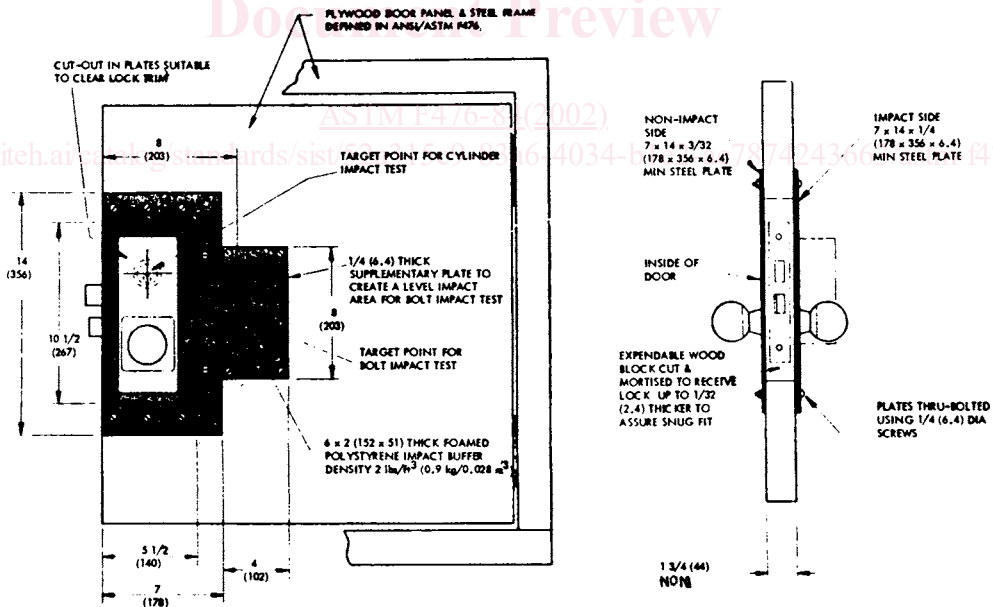
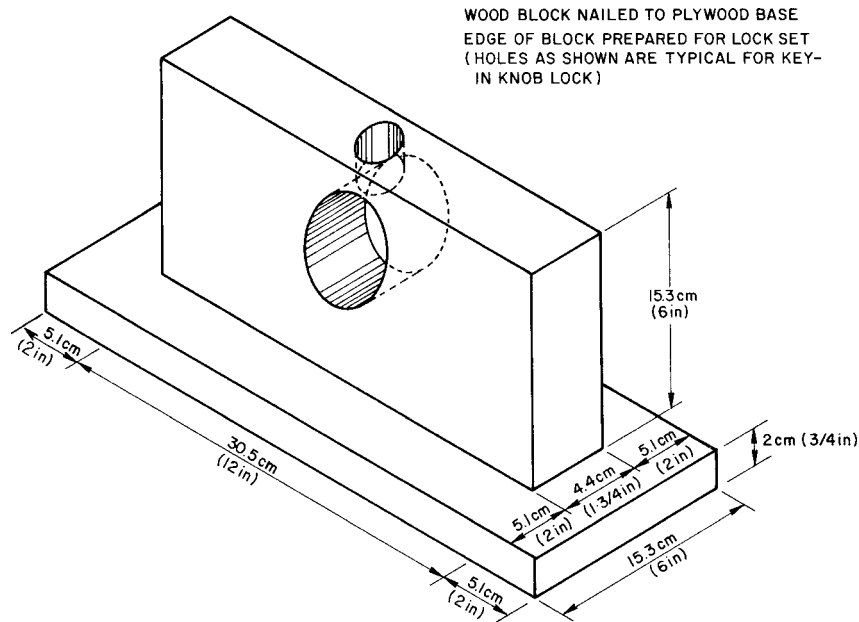

FIG. 4 Alternate Lockset Component Test Fixture



NOTE 1—The wood block is nailed to the plywood base edge of block prepared for lock set. (The holes as shown are typical for key-in knob lock.)

FIG. 5 Static Bolt Load Test Fixture

11.2 While the required load is being applied, or the lock front-to-strike distance is increased, push or pull on the door to determine whether the dead bolt or dead latch is engaged with the strike.

12. Knob Impact Test

12.1 Prepare the test specimen in accordance with 8.3 or 8.4 and lock the door or test panel in the closed position. Position the vertical impactor (5.1.3) so that the pendulum arm is horizontal when the striking weight contacts the top of the door knob, and its center of gravity is in the vertical center-line through the knob. Raise the weight to the height necessary to deliver the required impact and release it. Deliver the required number of impacts to the knob. After each impact, attempt to open the door or test panel by turning the knob. If the knob is broken off, manipulate the exposed lock mechanism by hand or with the aid of a screwdriver.

12.2 With the door or test panel open, and the dead bolt or dead latch in the projected, locked position, attempt to (a) depress the dead bolt by applying hand pressure to its end or (b) depress the latch and dead-latch plunger fully, allow the latch to extend, then slowly allow the plunger to project until the last point of dead locking is reached.

13. Cylinder-Core Tension Test

13.1 Prepare the test specimen in accordance with 8.3 or 8.4 and lock the door or test panel in the closed position. Drill a hole in the cylinder core using a No. 21 drill, adjacent to the keyway to a minimum depth of 13 mm (1/2 in.). Tap this hole with a 10-32 thread. Attach the tensile loading device (5.1.5) to a rigid load-bearing support in front of the cylinder, and align the pulling axis with that of the hole in the cylinder. Attach the pulling adapter to the cylinder with a 10-32 hardened cap screw fully threaded into the tapped hole. Connect the cylinder tensile loading device to the adapter, and apply the required tensile

force to the cylinder. Following this test, release the load and attempt to open the door or test panel by manipulating an exposed lock mechanism by hand or with the aid of a screwdriver. If the core or cylinder is not damaged, open the door, and test the dead latch or dead bolt for end pressure resistance as in 12.2.

14. Cylinder-Body Tension Test

14.1 Prepare the test specimen in accordance with 8.3 or 8.4 and lock the door or test panel in the closed position. Drill a hole in the cylinder body using a No. 3 drill, near the center of the cylinder face, to a minimum depth of 13 mm (1/2 in.). If the lock is constructed such that only the cylinder core is exposed, drill through the material covering the face of the cylinder body, into the cylinder. Tap this hole with a 1/4-28 thread. Attach the cylinder tensile loading device (5.1.5) to a rigid load-bearing support in front of the cylinder, and align the pulling axis with that of the hole in the cylinder. Attach the pulling adapter to the cylinder with a 1/4-28 hardened cap screw fully threaded into the tapped hole, or other appropriate devices. Connect the cylinder pulling device to the adapter, and apply the required tensile force to the cylinder. Following this test, release the load and attempt to open the door or test panel by manipulating an exposed lock mechanism by hand or with the aid of a screwdriver. If the cylinder is not damaged, open the door, and test the dead latch or dead bolt for end pressure resistance as in 12.2.

15. Knob Torque Test

15.1 Prepare the specimen test in accordance with 8.3 or 8.4 and lock the door or test panel in the closed position. Attach the torque-loading adapter to the knob and connect the torque applicator to it (5.1.4). Alternately subject the knob to the required torque in both the clockwise and counter-clockwise directions, applying the torque as rapidly as possible. Inspect