



Designation: **F2476–05 F2476 – 13**

Standard Test Method for the Determination of Carbon Dioxide Gas Transmission Rate (CO_2TR) Through Barrier Materials Using An Infrared Detector¹

This standard is issued under the fixed designation F2476; the number immediately following the designation indicates the year of original adoption or, in the case of revision, the year of last revision. A number in parentheses indicates the year of last reappraisal. A superscript epsilon (ϵ) indicates an editorial change since the last revision or reappraisal.

1. Scope

1.1 This method covers a procedure for determination of the steady-state rate of transmission of carbon dioxide gas through plastics in the form of film, sheeting, laminates, coextrusions, or plastic-coated papers or fabrics. It provides for the determination of (1) carbon dioxide gas transmission rate (CO_2TR), (2) the permeance of the film to carbon dioxide gas ($P'CO_2$), and (3) carbon dioxide permeability coefficient ($P''CO_2$) in the case of homogeneous materials.

1.2 *This standard does not purport to address all of the safety concerns, if any, associated with its use. It is the responsibility of the user of this standard to establish appropriate safety and health practices and determine the applicability of regulatory limitations prior to use.*

2. Referenced Documents

2.1 *ASTM Standards:*²

[D1898 Practice for Sampling of Plastics](#) (Withdrawn 1998)³

[E177 Practice for Use of the Terms Precision and Bias in ASTM Test Methods](#)

[E691 Practice for Conducting an Interlaboratory Study to Determine the Precision of a Test Method](#)

3. Terminology

3.1 *Definitions:*

3.1.1 *Carboncarbon dioxide permeability coefficient* ($P''CO_2$)—the product of the permeance and the thickness of film. The permeability is meaningful only for homogeneous materials, in which case it is a property characteristic of the bulk material. This quantity should not be used unless the relationship between thickness and permeance has been verified on tests using several different thicknesses of the material. The SI unit of carbon dioxide permeability is the mol/m·s·Pa. The test conditions (see 3.1.3) must be stated.

3.1.2 *Carboncarbon dioxide permeance* ($P'CO_2$)—the ratio of the CO_2TR to the difference between the partial pressure of CO_2 on the two sides of the film. The SI unit of permeance is the mol/(m²·s·Pa). The test conditions (see 3.1.3) must be stated.

3.1.3 *Carboncarbon dioxide transmission rate* (CO_2TR)—The quantity of carbon dioxide gas passing through a unit area of the parallel surfaces of a plastic film per unit time under the conditions of the test. The SI unit of transmission rate is the mol/(m²·s). The test conditions, including temperature and carbon dioxide partial pressure on both sides of the film, must be stated.

¹ This test method is under jurisdiction of ASTM Committee F02 on Flexible Barrier Packaging and is the direct responsibility of Subcommittee F02.10 on Permeation. Current edition approved Jan. 3, 2006/Dec. 15, 2013. Published May 2005/February 2014. Originally approved in 2005. Last previous edition approved in 2005 as F2476-05. DOI: 10.1520/F2476-05.10.1520/F2476-13.

² For referenced ASTM standards, visit the ASTM website, www.astm.org, or contact ASTM Customer Service at service@astm.org. For *Annual Book of ASTM Standards* volume information, refer to the standard's Document Summary page on the ASTM website.

³ The last approved version of this historical standard is referenced on www.astm.org.

3.1.3.1 Discussion—

A commonly used metric unit of CO_2TR is the cc(STP)/(m²·day) at one atmosphere driving force pressure differential where: 1 cc(STP) is 44.62 μ mol, 1 atm is 0.1013 MPa, and one day is 86.4 x 10³ s. CO_2TR in SI units is obtained by multiplying the value in metric units by 5.164 x 10⁻¹⁰ or the value in inch-pound units ($\frac{cm^3(STP)}{100\text{ in}^2(STP)} / (100\text{ in}^2 \cdot \text{day}) \cdot \text{day}$) by 8.004 x 10⁻⁹.

4. Summary of Test Method

4.1 The carbon dioxide gas transmission rate is determined after the sample has equilibrated in a dry-test environment. In this context, a “dry” environment is considered to be one in which the relative humidity is less than 1 %.

4.2 The specimen is mounted as a sealed semi-barrier between two chambers at ambient atmospheric pressure. One chamber is slowly purged by a stream of nitrogen and the other chamber with carbon dioxide. As carbon dioxide gas permeates through the film into the nitrogen carrier gas, it is transported to an infrared detector where an electrical output is produced whose magnitude is proportional to the amount of CO₂ flowing into the detector per unit of time.

5. Significance and Use

5.1 Carbon dioxide gas transmission rate (CO₂ TR) is an important determinant of the packaging protection afforded by barrier materials. It is not, however, the sole determinant, and additional tests, based on experience, must be used to correlate packaging performance with CO₂TR. It is suitable as a referee method of testing, provided that purchaser and seller have agreed on sampling procedures, standardization procedures, test conditions and acceptance criteria.

6. Apparatus

6.1 *Carbon Dioxide Gas Transmission Apparatus*, ~~Carbon Dioxide Gas Transmission Apparatus~~, as diagrammed in Fig. 1 or Fig. 2, with the following:

6.1.1 *Diffusion Cell*—shall consist of two metal halves, which, when closed upon the test specimen, will accurately define a circular area. A typical acceptable diffusion cell area is 50 cm². The volume enclosed by each cell half, when clamped, is not critical: it should be small enough to allow for rapid gas exchange, but not so small that an unsupported film that happens to sag or bulge will contact the top or bottom of the cell.

6.1.1.1 *O-Ring Groove*—an appropriately sized groove, machined into the CO₂ (or test gas) side of the diffusion cell, retains an elastomer O-ring. The test area is considered to be that area established by the inside contact diameter of the compressed O-ring when the diffusion cell is clamped shut against the test specimen. The area, A, can be obtained by measuring the inside diameter of the imprint left by the O-ring on the specimen after it has been removed from the diffusion cell.

6.1.1.2 The nitrogen (or carrier gas) side of the diffusion cell shall have a flat raised rim. Since this rim is a critical sealing surface against which the test specimen is pressed, it shall be smooth and flat, without radial scratches.

6.1.1.3 *Diffusion Cell Pneumatic Fittings*—each half of the diffusion cell shall incorporate suitable fittings for the introduction and exhaust of gases without significant loss or leakage.

6.1.1.4 It is desirable to thermostatically control the diffusion cell. Because the transmission rate is a function of temperature, it shall be controlled to within ± 0.1°C.

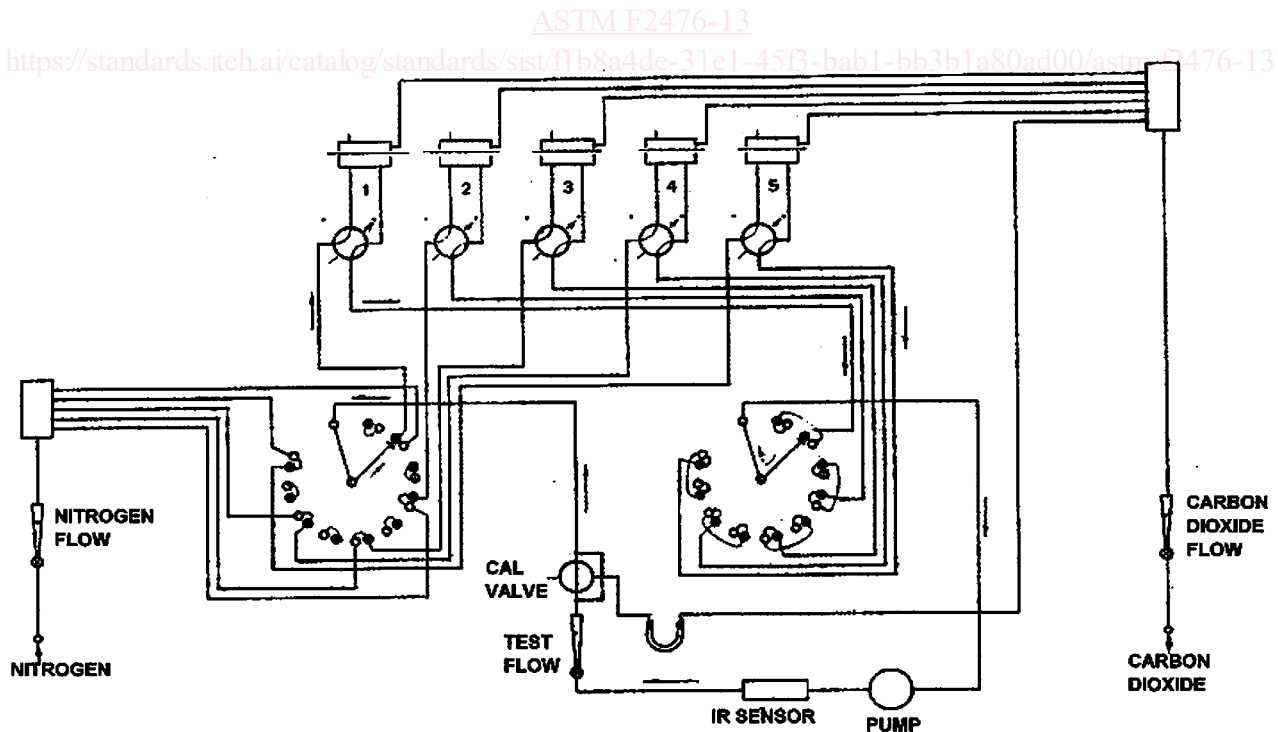

FIG. 1 A practical arrangement of components for the measurement of carbon dioxide transmission rate using a non-computerized system

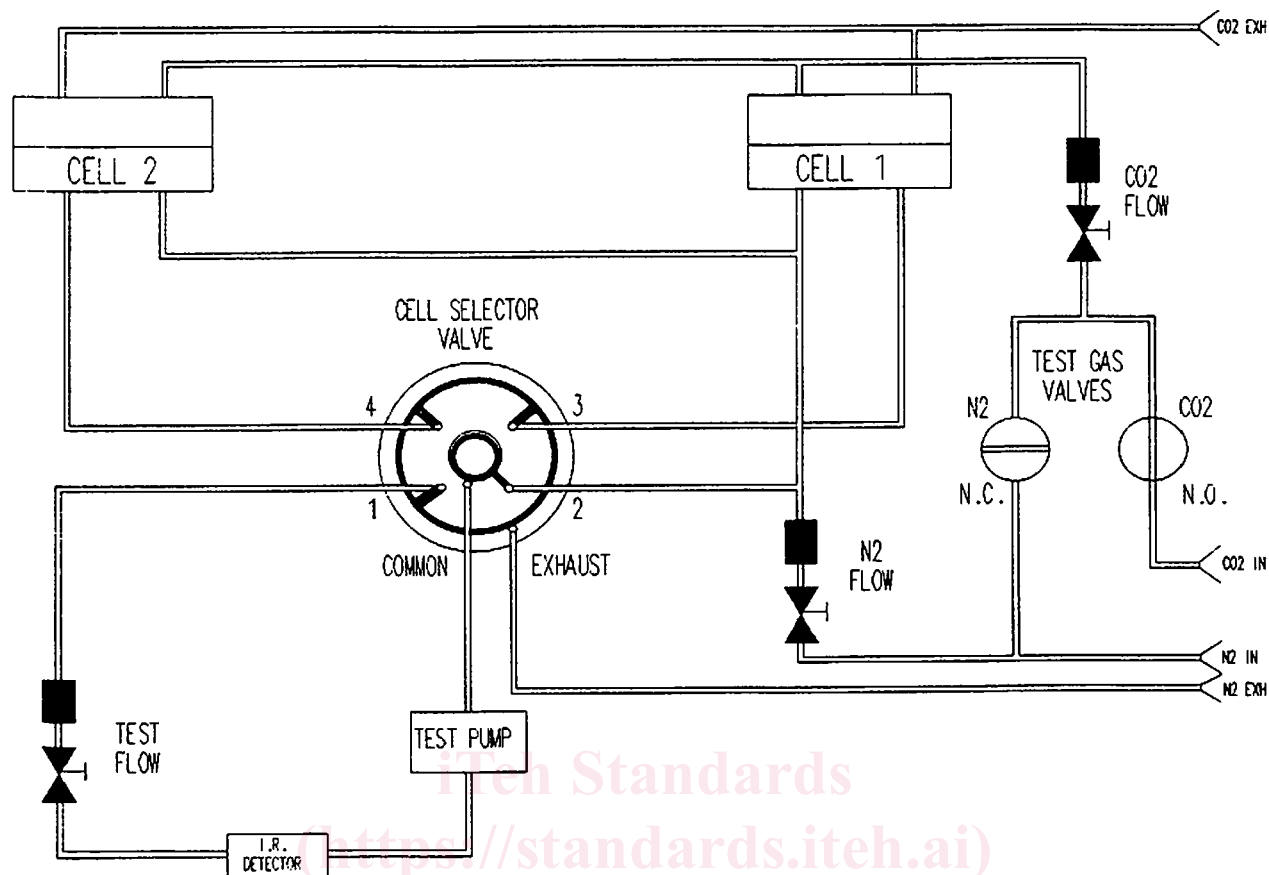

FIG. 2 A practical arrangement of components for the measurement of carbon dioxide transmission rate using a computerized system

ASTM F2476-13

6.1.1.5 Experience has shown that arrangements using multiple diffusion cells are a practical way to increase the number of measurements that can be obtained from an infrared sensor. A valving manifold connects the carrier gas side of each individual diffusion cell to the sensor in a predetermined pattern. Carrier gas is continually purging the carrier gas side of those cells that are not connected to the sensor. Either test gas or carrier gas, as is appropriate, purges the test gas chamber of any individual cell.

6.1.2 *Flowmeter*—a means shall be provided to establish and maintain test gas and carrier gas flows. An operating range in the order of 5 to 100 ml/min for CO₂ and up to 300 ml/min for N₂.

6.1.3 *Flow Switching Valves*—needed to perform the tasks of (1) purging, (2) accumulating, if needed, for static or dynamic testing methods, and (3) maintaining flow for continuous flow methods.

6.1.4 *Infrared sensor*—*Sensor*—a 4.3 μm infrared filter to measure the quantity of CO₂ in the carrier gas going to the sensor.

NOTE 1—The infrared sensor is not an absolute measuring device. Therefore, some standard has to be used to establish a point of reference. A means of providing a known quantity of CO₂ has been used and has been found satisfactory for this application. The use of a calibrated valve enables the system to establish the point of reference against which the unknown film is compared or the system may also be calibrated with a reference film.

6.1.5 *Recording device*—*Device*—a strip chart recorder or, if the system is computer- controlled, a monitor and a printer have been found to be adequate.

7. Reagents and Materials

7.1 *Nitrogen gas*—*Gas*—grade need not be higher than “High Purity” or “Extra Dry,” which is readily available in most of the principle principal cities at low cost. A regulator with auxiliary metering valve and outlet fittings for 1/8 in. tubing should be used.

7.2 *Carbon Dioxide gas*—*Gas*—a carbon dioxide concentration of 99.9 % or greater is suitable for this application.

7.3 *Sealing Grease*—a high-viscosity silicone stopcock grease or high-vacuum grease for sealing the specimen film in the diffusion cell.

7.4 *Aluminum Foil Reference Blank*—The term “reference blank” or “blocking plate” refers to a non-transmitting, zero reference aluminum foil sheet. Used in some instruments to establish system zero prior to testing film specimens.