



**International
Standard**

ISO 19403-7

**Paints and varnishes —
Wettability —**

**Part 7:
Measurement of the dynamic
contact angles and the roll-off angle
on a tilt stage**

Peintures et vernis — Mouillabilité —

*Partie 7: Mesurage des angles de contact dynamiques et de
l'angle de roulement sur un plan incliné*

**Second edition
2024-10**

iTeh Standards
(<https://standards.iteh.ai>)
Document Preview

[ISO 19403-7:2024](https://standards.iteh.ai/catalog/standards/iso/4d1e85a3-2d33-46ca-bca9-327f689a26f8/iso-19403-7-2024)

<https://standards.iteh.ai/catalog/standards/iso/4d1e85a3-2d33-46ca-bca9-327f689a26f8/iso-19403-7-2024>



COPYRIGHT PROTECTED DOCUMENT

© ISO 2024

All rights reserved. Unless otherwise specified, or required in the context of its implementation, no part of this publication may be reproduced or utilized otherwise in any form or by any means, electronic or mechanical, including photocopying, or posting on the internet or an intranet, without prior written permission. Permission can be requested from either ISO at the address below or ISO's member body in the country of the requester.

ISO copyright office
CP 401 • Ch. de Blandonnet 8
CH-1214 Vernier, Geneva
Phone: +41 22 749 01 11
Email: copyright@iso.org
Website: www.iso.org

Published in Switzerland

Contents

	Page
Foreword	iv
Introduction	v
1 Scope	1
2 Normative references	1
3 Terms and definitions	1
4 Principle	2
5 Apparatus and materials	2
6 Sampling	4
7 Procedure	4
7.1 General for measuring the roll-off angle.....	4
7.1.1 Setting up the contact angle measuring system.....	4
7.1.2 Test conditions.....	4
7.1.3 Conditioning of the test panels.....	4
7.2 Measurement.....	5
7.2.1 General.....	5
7.2.2 Application of the drop.....	5
7.2.3 Determination of the roll-off angle.....	6
8 Test report	8
Annex A (informative) Notes on sampling and treatment of test specimens	10
Annex B (informative) Factors influencing the roll-off angle	11
Bibliography	13

Document Preview

[ISO 19403-7:2024](https://standards.iteh.ai/standards/iso/4d1e85a3-2d33-46ca-bca9-327f689a26f8/iso-19403-7-2024)

<https://standards.iteh.ai/catalog/standards/iso/4d1e85a3-2d33-46ca-bca9-327f689a26f8/iso-19403-7-2024>

Foreword

ISO (the International Organization for Standardization) is a worldwide federation of national standards bodies (ISO member bodies). The work of preparing International Standards is normally carried out through ISO technical committees. Each member body interested in a subject for which a technical committee has been established has the right to be represented on that committee. International organizations, governmental and non-governmental, in liaison with ISO, also take part in the work. ISO collaborates closely with the International Electrotechnical Commission (IEC) on all matters of electrotechnical standardization.

The procedures used to develop this document and those intended for its further maintenance are described in the ISO/IEC Directives, Part 1. In particular, the different approval criteria needed for the different types of ISO document should be noted. This document was drafted in accordance with the editorial rules of the ISO/IEC Directives, Part 2 (see www.iso.org/directives).

ISO draws attention to the possibility that the implementation of this document may involve the use of (a) patent(s). ISO takes no position concerning the evidence, validity or applicability of any claimed patent rights in respect thereof. As of the date of publication of this document, ISO had not received notice of (a) patent(s) which may be required to implement this document. However, implementers are cautioned that this may not represent the latest information, which may be obtained from the patent database available at www.iso.org/patents. ISO shall not be held responsible for identifying any or all such patent rights.

Any trade name used in this document is information given for the convenience of users and does not constitute an endorsement.

For an explanation of the voluntary nature of standards, the meaning of ISO specific terms and expressions related to conformity assessment, as well as information about ISO's adherence to the World Trade Organization (WTO) principles in the Technical Barriers to Trade (TBT), see www.iso.org/iso/foreword.html.

This document was prepared by Technical Committee ISO/TC 35, *Paints and varnishes*, Subcommittee SC 9, *General test methods for paints and varnishes*, in collaboration with the European Committee for Standardization (CEN) Technical Committee CEN/TC 139, *Paints and varnishes*, in accordance with the Agreement on technical cooperation between ISO and CEN (Vienna Agreement).

This second edition cancels and replaces the first edition (ISO 19403-7:2017), which has been technically revised.

<https://standards.iteh.ai/catalog/standards/iso/4d1e85a3-2d33-46ca-bca9-327f689a26f8/iso-19403-7-2024>

The main changes are as follows:

- the title of the document has been changed;
- the term [3.2](#) “advancing angle” has been replaced by “dynamic advancing contact angle” and the definition has been reworded;
- the term [3.3](#) “receding angle” has been replaced by “dynamic receding contact angle” and the definition has been reworded;
- the minimum size of the text samples has been changed to 4 cm × 4 cm;
- the use of ethylene glycol as test liquid has been deleted;
- the normative references have been updated.

A list of all parts in the ISO 19403 series can be found on the ISO website.

Any feedback or questions on this document should be directed to the user's national standards body. A complete listing of these bodies can be found at www.iso.org/members.html.

Introduction

Dynamic contact angles describe the processes on the interface liquid or solid during volume increase (dynamic advancing contact angle) or volume decrease (dynamic receding contact angle) of a drop in horizontal position. As an alternative to the static method (see ISO 19403-2) a surface area is always wetted for the dynamic advancing contact angle, which was previously unwetted. For the dynamic receding contact angle, the contact angle is observed during dewetting. By determining the difference between the dynamic advancing contact angle and the dynamic receding contact angle, information on chemical homogeneity and roughness can be concluded. The dynamic receding contact angle is not suitable for the determination of the surface energy.

iTeh Standards
(<https://standards.iteh.ai>)
Document Preview

[ISO 19403-7:2024](https://standards.iteh.ai/catalog/standards/iso/4d1e85a3-2d33-46ca-bca9-327f689a26f8/iso-19403-7-2024)

<https://standards.iteh.ai/catalog/standards/iso/4d1e85a3-2d33-46ca-bca9-327f689a26f8/iso-19403-7-2024>

Paints and varnishes — Wettability —

Part 7:

Measurement of the dynamic contact angles and the roll-off angle on a tilt stage

1 Scope

This document specifies a method for the dynamic measurement of the roll-off angle on a tilt stage of a liquid drop on a solid surface. This document also specifies how the dynamic advancing and receding contact angles of the drop rolling off can be determined. The roll-off angle determined through this method can be applied when evaluating easy-to-clean or anti-adherent surfaces.

2 Normative references

The following documents are referred to in the text in such a way that some or all of their content constitutes requirements of this document. For dated references, only the edition cited applies. For undated references, the latest edition of the referenced document (including any amendments) applies.

ISO 4618, *Paints and varnishes — Vocabulary*

ISO 19403-1, *Paints and varnishes — Wettability — Part 1: Vocabulary and general principles*

3 Terms and definitions

For the purposes of this document, the terms and definitions given in ISO 4618, ISO 19403-1 and the following apply.

ISO and IEC maintain terminology databases for use in standardization at the following addresses:

- ISO Online browsing platform: available at <https://www.iso.org/obp>
- IEC Electropedia: available at <https://www.electropedia.org/>

3.1 roll-off angle

α_s
tipping of the surface of the solid body, which arises from the rolling off of a liquid drop that is put down onto this surface

3.2 dynamic advancing contact angle

dynamic advancing angle

θ_a
contact angle measured at the three-phase line during advancing the liquid phase

Note 1 to entry: The values depend on the method.

[SOURCE: ISO 19403-6:2024, 3.2]

3.3

dynamic receding contact angle

dynamic receding angle

θ_r

contact angle measured at the three-phase line during receding the liquid phase

Note 1 to entry: The values depend on the method.

[SOURCE: ISO 19403-6:2024, 3.3]

4 Principle

A drop is put down onto the surface to be tested. The surface is tipped with constant inclination speed until the drop rolls off. The progressing angle is determined from the temporal tracking of the wetting three-phase point and the dynamic receding contact angle from the temporal tracking of the dewetting three-phase point.

5 Apparatus and materials

Ordinary laboratory apparatus, together with the following, shall be used.

5.1 Contact angle measuring system, i.e. any state-of-the-art contact angle measuring device fitted with a tilting device. It is preferred to use systems with digital image capture and analysis for measuring the contact angle. [Figure 1](#) shows a system for which the camera as well as the sample table are inclined. [Figure 2](#) shows a schematic example of a contact angle measuring system for which only the sample table is inclined.

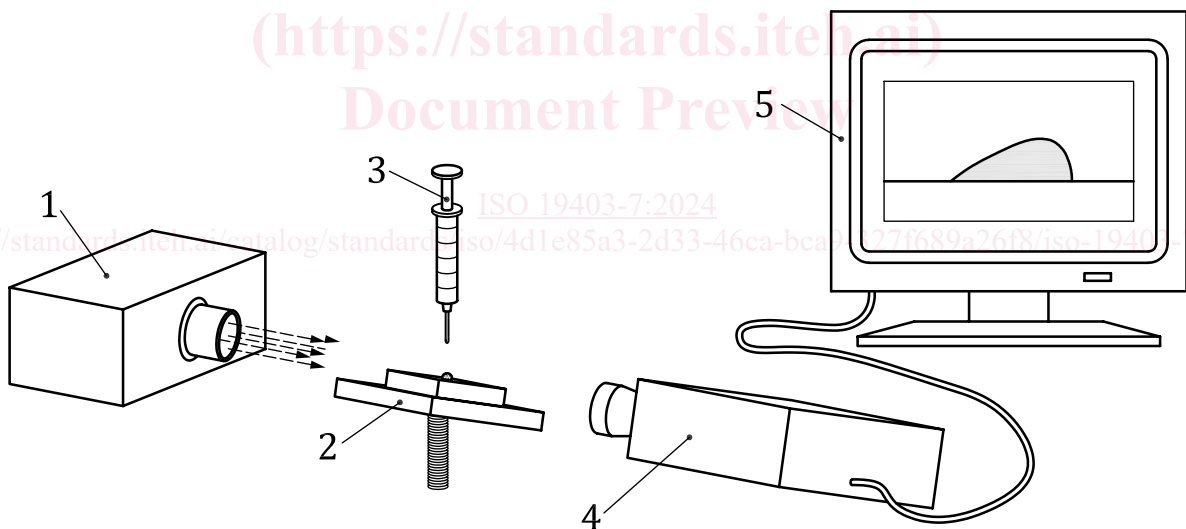

Key

- 1 light source
- 2 specimen holder
- 3 graduated microsyringe
- 4 optical system
- 5 screen

Figure 1 — Schematic diagram of a contact angle measuring system for which the camera as well as the sample table are inclined

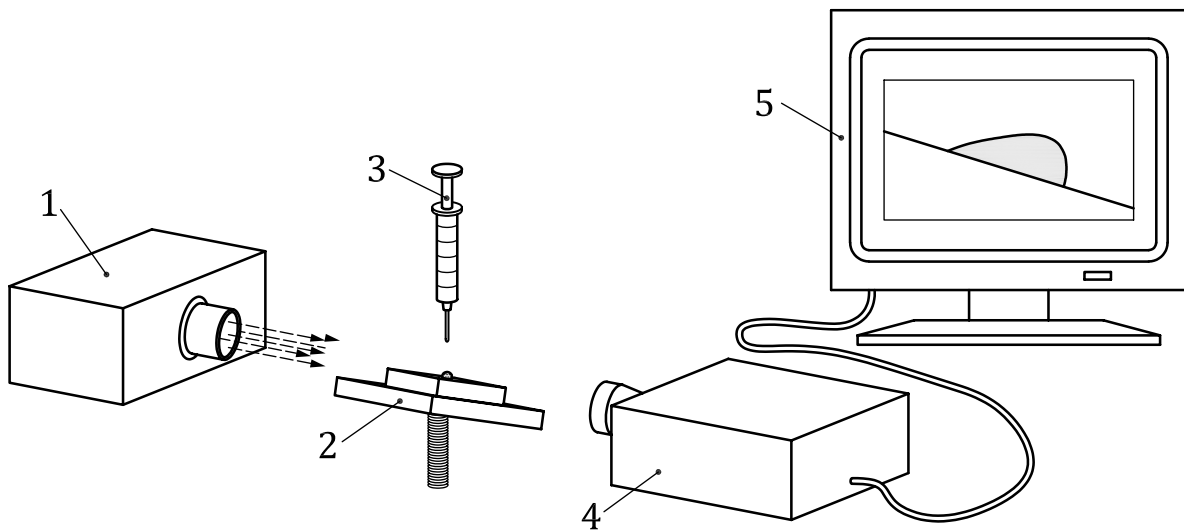

Key

- 1 light source
- 2 specimen holder
- 3 graduated microsyringe
- 4 optical system
- 5 screen

NOTE The device used can differ from the schematic diagram regarding light path and the arrangement of the components.

Figure 2 — Schematic diagram of a contact angle measuring system for which only the sample table is inclined

The image capturing system should be oriented in a way that the drop is within the left third of the image (when the table is inclined to the right).

5.2 Dosing unit, which makes it possible to precisely apply drops in the range of microlitres to the surface.

5.3 Test liquids, of at least purity grade “for analysis”. Water shall have a surface tension of at least 71,5 mN/m at standard climate, i.e. (23 ± 2) °C and (50 ± 5) % relative humidity.

If not otherwise agreed, use at least one of the test liquids suggested in [Table 1](#).

It is recommended to measure the surface tension of the liquids to be used according to ISO 19403-3. For guidance, the values from the literature for the surface tension, σ_l , are indicated in [Table 1](#). It is also possible to use an individually measured value of the surface tension as a reference value. According to experience, the measured value should not deviate more than ±2 % from the value specified in the literature or the individually determined value.

The test liquids shall not physically or chemically affect the surface. They shall not have a yield point.

The test liquids shall not cross-link, show any skinning or evaporate during the measurement.

Liquids having a vapour pressure higher than water at 30 °C shall be measured in the saturated vapour phase.

NOTE The values given in [Table 1](#) refer to 25 °C measuring temperature. For measuring under standard atmosphere (see [7.1.2](#)), no significant deviations can be assumed.

Table 1 — Suggested test liquids

Test liquid	Surface tension σ_1 mN/m	Dispersive fraction σ_1^d mN/m	Polar fraction σ_1^p mN/m	Source
Water	72,8	21,8	51,0	Reference [5]
Di-iodomethane	50,8	50,8	0,0	Reference [5]
1,2,3-propanetriol (glycerol)	63,4	37,0	26,4	Reference [5]
Hexadecane	27,6	27,6	0,0	Reference [5]
1-bromo-naphthalene	44,6	44,6	0,0	Reference [5]
Benzyl alcohol	38,9	29,0	9,9	Reference [6]
Decalin (isomer mixture)	30,6	30,6	0,0	Reference [5]
cis-Decalin	32,2	32,2	0,0	Reference [7]
trans-Decalin	29,9	29,9	0,0	Reference [7]

6 Sampling

Take a representative specimen of the substrate to be tested. The specimens shall not be contaminated before measuring.

Preferably, the specimen should have the minimum size of 4 cm × 4 cm and be as flat as possible.

For advice on sampling and sample preparation, see [Annex A](#).

7 Procedure

7.1 General for measuring the roll-off angle

7.1.1 Setting up the contact angle measuring system

Choose the location of the contact angle measuring system so that it is not exposed to:

- vibrations,
- intense air flows (e.g. caused by air conditioning), and
- intense exposure to light from outside (e.g. windows, bright lighting).

Align the contact angle measuring system horizontally.

7.1.2 Test conditions

Carry out the test at (23 ± 2) °C and a relative humidity of (50 ± 5) % (see ISO 3270) and make sure that all test media have this temperature.

7.1.3 Conditioning of the test panels

Condition the test panels at a temperature of (23 ± 2) °C and a relative humidity of (50 ± 5) % for a minimum of 16 h prior to testing. Carry out the test immediately after conditioning.