



Designation: C1684 – 13^{ε1}

Standard Test Method for Flexural Strength of Advanced Ceramics at Ambient Temperature—Cylindrical Rod Strength¹

This standard is issued under the fixed designation C1684; the number immediately following the designation indicates the year of original adoption or, in the case of revision, the year of last revision. A number in parentheses indicates the year of last reappraisal. A superscript epsilon (ϵ) indicates an editorial change since the last revision or reappraisal.

^{ε1} NOTE—Units statement was added to the scope editorially in April 2014.

1. Scope

1.1 This test method is for the determination of flexural strength of rod shape specimens of advanced ceramic materials at ambient temperature. In many instances it is preferable to test round specimens rather than rectangular bend specimens, especially if the material is fabricated in rod form. This method permits testing of machined, drawn, or as-fired rod shaped specimens. It allows some latitude in the rod sizes and cross section shape uniformity. Rod diameters between 1.5 and 8 mm and lengths from 25 to 85 mm are recommended, but other sizes are permitted. Four-point- $1/4$ point as shown in Fig. 1 is the preferred testing configuration. Three-point loading is permitted. This method describes the apparatus, specimen requirements, test procedure, calculations, and reporting requirements. The method is applicable to monolithic or particulate- or whisker-reinforced ceramics. It may also be used for glasses. It is not applicable to continuous fiber-reinforced ceramic composites.

1.2 The values stated in SI units are to be regarded as the standard. The values given in parentheses are for information only.

1.3 *This standard does not purport to address all of the safety concerns, if any, associated with its use. It is the responsibility of the user of this standard to establish appropriate safety and health practices and determine the applicability of regulatory limitations prior to use.*

2. Referenced Documents

2.1 ASTM Standards:²

C158 Test Methods for Strength of Glass by Flexure (De-

termination of Modulus of Rupture)
C1145 Terminology of Advanced Ceramics
C1161 Test Method for Flexural Strength of Advanced Ceramics at Ambient Temperature
C1239 Practice for Reporting Uniaxial Strength Data and Estimating Weibull Distribution Parameters for Advanced Ceramics
C1322 Practice for Fractography and Characterization of Fracture Origins in Advanced Ceramics
C1368 Test Method for Determination of Slow Crack Growth Parameters of Advanced Ceramics by Constant Stress-Rate Strength Testing at Ambient Temperature
E4 Practices for Force Verification of Testing Machines
E337 Test Method for Measuring Humidity with a Psychrometer (the Measurement of Wet- and Dry-Bulb Temperatures)

3. Terminology

3.1 Definitions:

3.1.1 *complete gage section, n*—the portion of the specimen between the two outer loading points in four-point flexure and three-point flexure fixtures. **C1161**

3.1.2 *flaw, n*—a structural discontinuity in an advanced ceramic body that acts as a highly localized stress raiser.

3.1.2.1 *Discussion*—The presence of such discontinuities does not necessarily imply that the ceramic has been prepared improperly or is faulty. **C1322**

3.1.3 *flexural strength, n*—a measure of the ultimate strength of a specified beam in bending. **C1145, C1161**

3.1.4 *four-point- $1/4$ point flexure, n*—configuration of flexural strength testing where a specimen is symmetrically loaded at two locations that are situated one quarter of the overall span away from the outer two support loading points (see Fig. 1). **C1145, C1161**

3.1.5 *fracture origin, n*—the source from which brittle fracture commences. **C1145, C1322**

3.1.6 *inert flexural strength, n*—a measure of the strength of specified beam in bending as determined in an appropriate inert condition whereby no slow crack growth occurs.

3.1.6.1 *Discussion*—An inert condition may be obtained by

¹ This test method is under the jurisdiction of ASTM Committee C28 on Advanced Ceramics and is the direct responsibility of Subcommittee C28.01 on Mechanical Properties and Performance.

Current edition approved Aug. 1, 2013. Published September 2013. Originally approved in 2008. Last previous edition approved in 2008 as C1684 – 08. DOI: 10.1520/C1684-13E01.

² For referenced ASTM standards, visit the ASTM website, www.astm.org, or contact ASTM Customer Service at service@astm.org. For *Annual Book of ASTM Standards* volume information, refer to the standard's Document Summary page on the ASTM website.

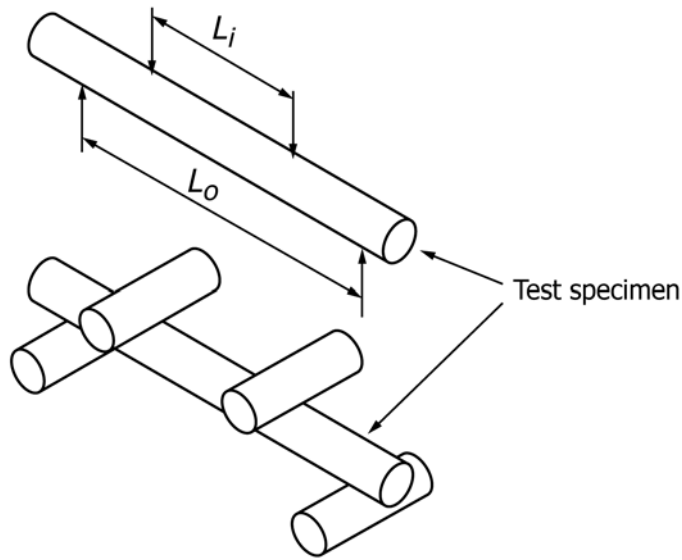

FIG. 1 Four-Point-1/4 Point Flexure Loading Configuration

using vacuum, low temperatures, very fast test rates, or any inert media. **C1161**

3.1.7 *inherent flexural strength, n*—the flexural strength of a material in the absence of any effect of surface grinding or other surface finishing process, or of extraneous damage that may be present. The measured inherent strength is in general a function of the flexure test method, test conditions, and specimen size. **C1161**

3.1.8 *inner gage section, n*—the portion of the specimen between the inner two loading points in a four-point flexure fixture. **C1161**

3.1.9 *slow crack growth (SCG), n*—subcritical crack growth (extension) which may result from, but is not restricted to, such mechanisms as environmentally-assisted stress corrosion or diffusive crack growth. **C1145, C1161**

3.1.10 *three-point flexure, n*—configuration of flexural strength testing where a specimen is loaded at a location midway between two support loading points (see Fig. 2). **C1145, C1161**

4. Significance and Use

4.1 This test method may be used for material development, quality control, characterization, and design data generation purposes. This test method is intended to be used with ceramics whose strength is 50 MPa (~7 ksi) or greater. The test method may also be used with glass test specimens, although Test Methods C158 is specifically designed to be used for glasses. This test method may be used with machined, drawn, extruded, and as-fired round specimens. This test method may be used with specimens that have elliptical cross section geometries.

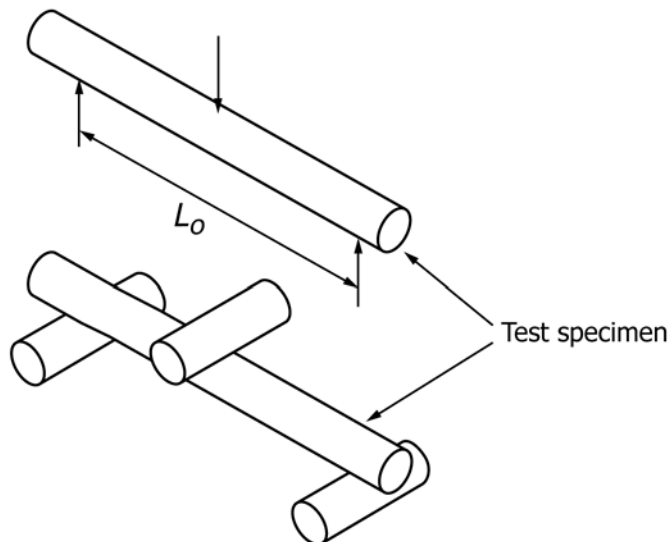

FIG. 2 Three-Point Flexure Loading Configuration

4.2 The flexure strength is computed based on simple beam theory with assumptions that the material is isotropic and homogeneous, the moduli of elasticity in tension and compression are identical, and the material is linearly elastic. The average grain size should be no greater than one fiftieth of the rod diameter. The homogeneity and isotropy assumptions in the standard rule out the use of this test for continuous fiber-reinforced ceramics.

4.3 Flexural strength of a group of test specimens is influenced by several parameters associated with the test procedure. Such factors include the loading rate, test environment, specimen size, specimen preparation, and test fixtures (1-3).³ This method includes specific specimen-fixture size combinations, but permits alternative configurations within specified limits. These combinations were chosen to be practical, to minimize experimental error, and permit easy comparison of cylindrical rod strengths with data for other configurations. Equations for the Weibull effective volume and Weibull effective surface are included.

4.4 The flexural strength of a ceramic material is dependent on both its inherent resistance to fracture and the size and severity of flaws in the material. Flaws in rods may be intrinsically volume-distributed throughout the bulk. Some of these flaws by chance may be located at or near the outer surface. Flaws may alternatively be intrinsically surface-distributed with all flaws located on the outer specimen surface. Grinding cracks fit the latter category. Variations in the flaws cause a natural scatter in strengths for a set of test specimens. Fractographic analysis of fracture surfaces, although beyond the scope of this standard, is highly recommended for all purposes, especially if the data will be used for design as discussed in Refs (3-5) and Practices C1322 and C1239.

4.5 The three-point test configuration exposes only a very small portion of the specimen to the maximum stress. Therefore, three-point flexural strengths are likely to be greater than four-point flexural strengths. Three-point flexure has some advantages. It uses simpler test fixtures, it is easier to adapt to high temperature and fracture toughness testing, and it is sometimes helpful in Weibull statistical studies. It also uses smaller force to break a specimen. It is also convenient for very short, stubby specimens which would be difficult to test in four-point loading. Nevertheless, four-point flexure is preferred and recommended for most characterization purposes.

5. Interferences

5.1 The effects of time-dependent phenomena, such as stress corrosion or slow crack growth on strength tests conducted at ambient temperature, can be meaningful even for the relatively short times involved during testing. Such influences must be considered if flexure tests are to be used to generate design data. Slow crack growth can lead to a rate dependency of flexural strength. The testing rate specified in this standard may or may not produce the inert flexural strength whereby negligible slow crack growth occurs. See Test Method C1368.

³ The boldface numbers in parentheses refer to the list of references at the end of this standard.

5.2 Surface preparation of test specimens can introduce machining microcracks which may have a pronounced effect on flexural strength (6). Machining damage imposed during specimen preparation can be either a random interfering factor, or an inherent part of the strength characteristic to be measured. With proper care and good machining practice, it is possible to obtain fractures from the material's natural flaws. Surface preparation can also lead to residual stresses. It should be understood that final machining steps may or may not negate machining damage introduced during the early coarse or intermediate machining.

5.3 This test method allows several options for the preparation of specimens. The method allows testing of as-fabricated (e.g., as-fired or as-drawn), application-matched machining, customary, or one of three specific grinding procedures. The latter "standard procedures" (see 7.2.4) are satisfactory for many (but certainly not all) ceramics. Centerless or transverse grinding aligns the severest machining microcracks perpendicular to the rod tension stress axis. The specimen may fracture from the machining microcracks. Transverse-ground specimens in many instances may provide a more "practical strength" that is relevant to machined ceramic components whereby it may not be possible to favorably align the machining direction. Therefore, this test method allows transverse grinding for normal specimen preparation purposes. Longitudinal grinding, which is commonly used to orient grinding damage cracks in rectangular bend bars, is less commonly used for rod specimens, but is also permitted by this test method.

6. Apparatus

6.1 *Loading*—Specimens may be loaded in any suitable testing machine provided that uniform rates of direct loading can be maintained. The force measuring system shall be free of initial lag at the loading rates used and shall be equipped with a means for retaining read-out of the maximum force applied to the specimen. The accuracy of the testing machine shall be in accordance with Practices E4.

6.2 *Four-Point Flexure*—Four-point- $\frac{1}{4}$ point fixtures are the preferred configuration. When possible, use one of the outer support and inner loading span combinations listed in Table 1. Other span sizes may be used if these sizes are not suitable for a specific round part. The ratio of the fixture outer span length to the specimen diameter shall not be less than 3.0.

6.3 *Three-Point Flexure*—Three-point flexure may be used if four-point is not satisfactory, such as if the specimens are very short and stubby and consequently require very large breaking forces in four-point loading. When possible, use one of the support spans listed in Table 1 for three-point loading. Other span sizes may be used if these sizes are not suitable for

TABLE 1 Preferred Fixture Spans

Configuration	Support Outer Span (L_s), mm	Loading Inner Span (L_l), mm
A	20	10
B	40	20
C	80	40

a specific round part. The outer fixture span length to specimen diameter ratio shall not be less than 3.0.

6.4 *Loading Rollers*—Force shall be applied to the test pieces directly by rollers as described in this section (6.4) or alternatively by rollers with cradles as described in 6.5.

6.4.1 This test method permits direct contact of rod specimens with loading and support rollers. Direct contact may cause two problems, however. The crossed cylinder arrangement creates intense contact stresses in both the loading roller and the test specimen due to the very small contact footprint. The magnitude of the contact stresses depends upon the applied forces, the roller and test specimen diameters, and their elastic properties.

6.4.2 Section 6.4.5 provides guidance on how to minimize or eliminate permanent deformation that may occur in the loading rollers due to contact stresses.

6.4.3 Direct loading by rollers onto the rod test specimens may cause premature test specimen fracture invalidating the test. Examples are shown in Annex A1. Contact stresses may generate shallow Hertzian cone cracks in the test specimen. Minor cracking at an inner loading point (on the compression-loaded side of the test rod) usually is harmless since it does not cause specimen breakage and forces are transmitted through the crack faces. In extreme conditions, however, such as loading of short stubby specimens in 3-point or 4-point loading, the magnitude of the forces and contact stresses may be great enough to drive a Hertzian crack deep into the test

specimen cross section. Contact cracks at the outer support rollers may be deleterious and cause an undesirable fracture of the specimen, even though these locations are far away from the inner span in 4-point loading or the middle in 3-point loading. Examples of such deleterious contact cracks are shown in Annex A1. The propensity for fracture from contact cracks depends upon the test material properties and the testing configuration. The lower the material’s fracture toughness and the higher the elastic modulus, the more likely that contact cracks will cause premature fracture. The larger the test specimen diameter for a given test span, the more likely that contact fracture will occur since larger forces are applied to break them. In other words, short stubby rod specimens are more likely to have problems than long slender rods. This standard allows considerable latitude in the selection of specimen sizes and testing geometries. If specimens break prematurely from contact cracks, the user shall either: reduce the test specimen diameter, or use longer rod specimens with longer span test fixtures, or use fixtures with cradles (see 6.5), or shift to three-point loading.

6.4.4 The rollers shall be free to rotate or roll to minimize frictional constraint as the specimen stretches or contracts during loading. The sole exception is the middle-load roller in three-point flexure which need not rotate. Note that the outer-support rollers roll *outward* and the inner-loading rollers roll *inward*. The rollers may roll on a fixture base as shown in Fig. 3 or alternatively, they may be mounted in roller assem-

(<https://standards.iteh.ai>)

Document Preview

ASTM C1684-13e1

<https://standards.iteh.ai/catalog/standards/sist/71494254840519721b13524421/astm-c1684-13e1>

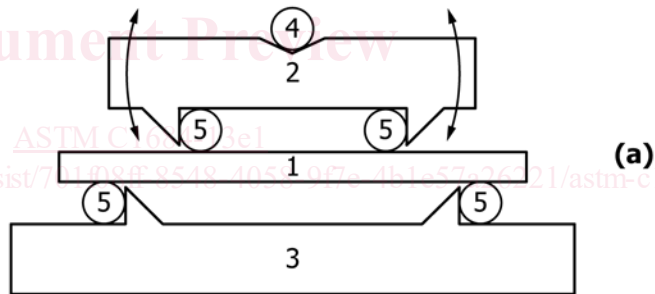

Key:

- 1 rod specimen
- 2 upper roller support
- 3 lower roller support
- 4 pivot roller
- 5 loading rollers

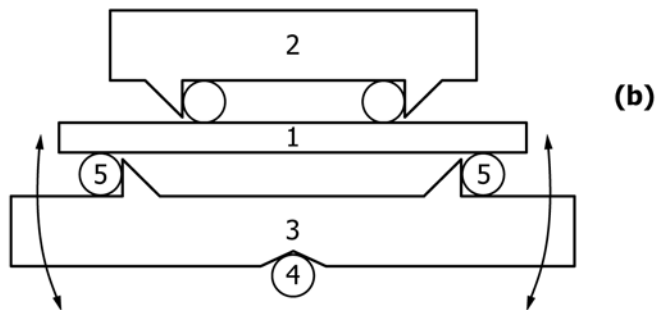

NOTE 1—The loading and support rollers are free to roll to relieve frictional constraints. The outer rollers roll outward and the inner rollers roll inward. Either the upper (shown in a) or the lower support piece (shown in b) should be free to pivot or “articulate” to ensure even loading on the left and right rollers. The curved arrows show this action. Such pivoting or “articulation” is not necessary for three-point loading. Rubber bands, magnets, or low stiffness springs may hold the rollers up against the positioning shoulders.

FIG. 3 Four-Point Fixture Schematic

blies that allow them to rotate. Cradle inserts such as shown in Fig. 4 may be used in conjunction with loading rollers if necessary to eliminate fractures at the loading points induced by severe contact loading stresses associated with a round specimen in contact with round loading rollers.

NOTE 1—Fixtures suitable for Test Method C1161 for rectangular cross section specimens may be used with rod specimens. Fully-articulating fixtures as defined in C1161 are *not* required for rod specimens due to ease of applying force to a cylindrical specimen. Semi-articulating fixtures as defined in C1161 are satisfactory for four-point loading of rods. *No* articulation is needed for three-point loading. Loading rollers were referred to as “bearings” in Test Method C1161.

6.4.5 The load application rollers shall be made of hardened steel or a dense strong ceramic. The portions of the test fixture that support the rollers may need to be hardened to prevent permanent deformation. The roller length shall be at least three times the specimen diameter. The range of specimen sizes, fixture sizes, and materials permitted by this standard for rod specimens is so broad that it is difficult to specify a single hardness requirement. Therefore it is recommended that hardened steel dowel rollers with hardness of HRC 60 or greater be used as the loading and support rollers. These should be checked after breaking a few specimens and if there is evidence of permanent deformation, then harder rollers should be substituted or cradles used as per 6.5. Minor scuff marks, scratches, or small nicks on the rollers do not require the rollers to be replaced.

6.4.6 The roller diameter should be 0.75 to 1.5 times the diameter of the test specimen size. Table 2 lists some suggested sizes. Other sizes are permitted if necessary for unusual sized test specimens. Smaller diameter rollers may cause excessive contact stresses. Larger diameter rollers may cause stress errors due to contact point tangency shift as the specimen deflects under load. All rollers shall be straight and uniform in diameter and have the same diameter to within ± 0.025 mm.

6.4.7 The rollers shall be carefully positioned such that the spans are accurate within ± 0.10 mm. The load application rollers for the three-point configurations shall be positioned midway between the support rollers within ± 0.10 mm. The load application (inner) rollers for the four-point configurations shall be centered with respect to the support (outer) rollers within ± 0.10 mm.

TABLE 2 Suggested Nominal Roller Diameters

Configuration	Diameter, mm
A	1.0–3.0
B	2.2–6.0
C	4.5–12.0

6.4.8 All rollers should be approximately parallel to each other.

NOTE 2—The rollers do not need be as precisely parallel as specified in Test Method C1161 for fixtures intended to be used for rectangular flexure specimens. Unlike rectangular specimens, round rods are much less susceptible to twisting errors. In general, any fixture suitable for rectangular specimens will have rollers that are sufficiently parallel for round rods.

6.5 Cradles—If direct contact of loading rollers on the specimen causes fractures at the loading points, then cradle inserts may be used between the test specimen and the rollers as shown in Fig. 4 and in Annex A2. The cradles will relieve most of the contact stresses and eliminate contact crack fractures. A cradle shall *not* be used for the middle loading point in three-point loading.

6.6 The fixture shall be stiffer than the specimen, so that most of the crosshead travel is imposed onto the specimen. Fixture compliance should be measured. An oversized block or rod may be inserted into the fixture and force applied up to the levels expected for a test series. The load-displacement record can be used to compute the system stiffness or compliance.

6.7 Micrometer—A micrometer with a resolution of 0.002 mm (or 0.0001 in.) or smaller should be used to measure the test piece dimensions. The micrometer shall have flat anvil faces. The micrometer shall not have a ball tip or sharp tip since these might damage the test piece if the specimen dimensions are measured prior to fracture. Alternative dimension measuring instruments may be used provided that they have a resolution of 0.002 mm (or 0.0001 in.) or finer and do no harm to the specimen.

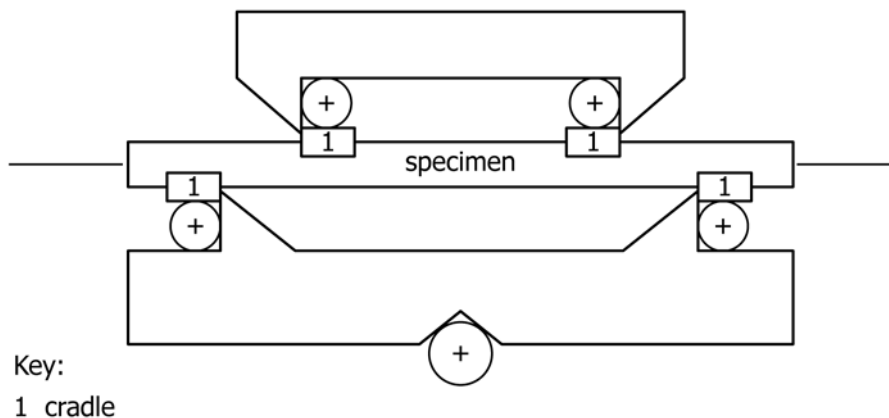

NOTE 1—Cradles may be used between the rollers and the specimen. See Annex A2 for more information about cradles.

FIG. 4 Four-Point Fixture with Cradles Schematic

7. Sampling, Test Specimens, and Test Units

7.1 *Test Specimen Size*—Recommended and allowed test specimen dimensions are given in Table 3. The fixture span length (L_o) to specimen diameter (D) ratio shall not be less than 3.0.

NOTE 3—A range of test specimen diameters is allowed by this standard, unlike Test Method C1161 for rectangular beams which specifies fixed sizes. Rods are more likely to be related to some component shape and some flexibility in specimen size is desirable, albeit at some loss of ease in comparing strength data for different rod sizes.

NOTE 4—Some caution should be exercised in the choice of test specimen diameter. The fixture span length to specimen diameter ratio (L_o/D) limitation of >3.0 is intended to ensure that stress distribution is correct. However, some materials may be susceptible to contact damage for low L_o/D ratios that causes premature fracture that invalidates the test. See 6.4.3. Whenever possible, use fixture spans with larger L_o/D ratios.

7.2 *Specimen Preparation*—Depending upon the intended application of the flexural strength data, use one of the following four test specimen preparation procedures:

NOTE 5—This test method does not specify a test piece surface finish. Surface finish may be very misleading since a ground, lapped, or even polished surface may conceal hidden (beneath the surface) cracking damage from rough or intermediate grinding.

7.2.1 *As-Fabricated*—The flexural specimen shall simulate the surface condition of an application where no machining is to be used; for example, drawn, extruded, injection molded, cast, and sintered parts. No additional grinding or surface finishing preparation is required. The rods do not need to be perfectly round. This method permits the use of elliptical cross section specimens.

7.2.2 *Application-Matched Machining*—The specimen shall have the same surface preparation as that given to a component. Unless the process is proprietary, the report shall be specific about the stages of material removal, wheel grits, wheel bonding, and the amount of material removed per pass.

7.2.3 *Customary Procedures*—In instances where a customary machining procedure has been developed that is completely satisfactory for a class of materials (that is, it induces no unwanted surface damage or residual stresses), this procedure shall be used.

7.2.4 *Standard Procedures*—In the instances where 7.2.1 through 7.2.3 are not appropriate, then 7.2.4 shall apply. Three alternative grinding modes may be used. Machining may be in the centerless grinding, or transverse grinding, or longitudinal grinding modes. The procedures below shall serve as minimum requirements and more stringent procedures may be necessary. All grinding shall be done with an ample supply of appropriate filtered coolant to keep work piece and wheel constantly

flooded and particles flushed. Grinding shall be in two or three stages, ranging from coarse to fine rates of material removal. The choice of bond system (resin, vitrified), diamond type (natural or synthetic, coated or uncoated, friability, shape, etc.) and concentration (percent of diamond in the wheel) is at the discretion of the user. The two end faces do not require special machining.

NOTE 6—These procedures have been demonstrated to be effective in minimizing or eliminating grinding cracks as strength limiting flaws in silicon nitride (6).

NOTE 7—The sound of the grinding wheel during the grinding process may be a useful indicator of whether the grinding wheel condition and material removal conditions are appropriate. It is beyond the scope of this standard to specify the auditory responses, however.

7.2.4.1 Transverse Centerless Grinding:

(1) Coarse grinding shall be by a diamond wheel that is between 180 grit to 320 grit. The in-feed (wheel depth of cut) shall not exceed 0.050 mm (0.002 in.) per pass (for a 0.050 mm diameter change) to a diameter that is oversized by 0.050 mm (0.002 in.) to 0.100 mm (0.004 in.). The wheel surface speed should be between 15 and 40 m/s.

(a) Note—This procedure is similar to that of transverse cylindrical grinding in 7.2.4.2, but the allowed in-feeds are greater due to the nature of the centerless grinding set up.

(2) Intermediate grinding, if used, shall be by a diamond wheel that is between 200 and 400 grit. The in-feed shall not exceed 0.050 mm/pass to a diameter that is oversized by at least 0.050 mm (0.002 in.). The wheel surface speed should be between 15 and 40 m/s.

(3) Finish grinding shall be with a 600 grit diamond wheel. The in-feed shall not exceed 0.005 mm (0.0002 in.). Final grinding shall remove no less than 0.050 mm (0.002 in.) from the diameter. The wheel surface speed should be between 15 and 40 m/s.

7.2.4.2 Transverse Cylindrical Grinding:

(1) Coarse grinding shall be by a diamond wheel that is between 180 grit to 320 grit. The in-feed (wheel depth of cut) shall not exceed 0.025 mm (0.001 in.) per pass (for a 0.050 mm diameter change) to a diameter that is oversized by 0.050 mm (0.002 in.) to 0.100 mm (0.004 in.). The wheel surface speed should be between 15 and 40 m/s.

(a) Note—This procedure is similar to that of transverse centerless grinding in 7.2.4.1, but the allowed in-feeds are less due to the nature of the cylindrical grinding set up.

(2) Intermediate grinding, if used, shall be with a diamond wheel that is between 200 and 400 grit. The in-feed shall not exceed 0.025 mm/pass to a diameter that is oversized by at least 0.050 mm (0.002 in.). The wheel surface speed should be between 15 and 40 m/s.

(3) Finish grinding shall be with a 600 grit diamond wheel. The in-feed shall not exceed 0.005 mm (0.0002 in.). Final grinding shall remove no less than 0.050 mm (0.002 in.) from the diameter. The wheel surface speed should be between 15 and 40 m/s.

7.2.4.3 Longitudinal Centerless Ground:

(1) Coarse and intermediate grinding may be centerless or transverse grinding as specified in 7.2.4.1 or 7.2.4.2 to a diameter that is oversized by at least 0.050 mm (0.002 in.).

TABLE 3 Recommended and Allowable Specimen Sizes

Fixture Configuration	Support Span (L_o)	Recommended Specimen Diameter (D), mm	Allowable Specimen Diameter (D), ^A mm	Specimen Length (L_r), min, mm
A	20	1.5–2	1–6.7 ^A	25
B	40	3–4	2–13.3 ^A	45
C	80	6–8	4–27 ^A	85

^A Caution: Large diameter specimens may fracture from contact damage that invalidates the test. See 6.4.3.

(2) Finish longitudinal grinding shall be with a diamond wheel that is between 320 and 600 grit. The in-feed (wheel depth of cut) shall not exceed 0.005 mm (0.0002 in.). Remove no less than 0.050 mm (0.002 in.) from the diameter.

7.2.4.4 Materials with low fracture toughness and a greater susceptibility to grinding damage may require finer grinding wheels at very low removal rates.

7.2.4.5 Very deep skip marks or very deep single striations (which may occur due to a poor quality grinding wheel or due to a failure to true, dress, or balance a wheel) are not acceptable.

7.2.5 *Handling Precautions and Scratch Inspection*—Exercise care in storing and handling of specimens to avoid the introduction of random and severe flaws, such as might occur if specimens were allowed to impact or scratch each other. If required by the user, inspect the surfaces as required for evidence of grinding chatter, scratches, or other extraneous damage. A5× to 10× hand loupe or a low power stereo binocular microscope may be used to aid the examination. Mark the scratched area with a pencil or permanent marker if scratches or extraneous damage are detected. The damaged area should not be placed in tension, but instead on the compression mode of loading when the specimen is inserted into the test fixtures.

NOTE 8—Damage or scratches may be introduced by handling or mounting problems. Scratches are sometimes caused by loose abrasive grit.

7.3 *Number of Test Specimens*—A minimum of 10 test specimens shall be required for the purpose of estimating the mean. A minimum of 30 shall be necessary if estimates regarding the form of the strength distribution are to be reported (for example, a Weibull modulus) or if the data are to be used for design. The number of test specimens required by this test method has been established with the intent of determining not only reasonable confidence limits on strength distribution parameters, but also to help discern multiple-flaw population distributions. More than 30 test specimens are recommended if multiple-flaw populations are present.

NOTE 9—Practice C1239 may be consulted for additional guidance particularly if confidence intervals for estimates of Weibull parameters are of concern.

8. Procedure

8.1 Test specimen dimensions may be measured before testing, but it is simpler and preferable to measure round test specimens after fracture. See 8.12. If the test specimens are noticeably elliptical and the minor and major diameters differ by more than 5 %, the major and minor dimensions should be checked before testing so that the specimens can be inserted into the test fixture correctly as specified in 8.5.1. See 8.12 for the procedure to measure specimen dimensions.

8.2 Test specimens on the appropriate fixture. Test size A specimens on either the four-point A fixture or the three-point A fixture. Similarly, test B specimens on B fixtures, and C specimens on C fixtures. Four-point loading is preferred. Three-point loading may be used if the rods have a large diameter and require large break forces to fracture.

8.3 Carefully place each test specimen into the test fixture to preclude possible damage and to ensure alignment of the specimen in the fixture. Position the specimen so that there is an approximately equal amount of overhang of the test specimen beyond the outer rollers on each side. Position the specimen (in a front to back sense) so that the test specimen is directly centered below the axis of the applied load.

8.4 Slowly apply the force at right angles to the fixture. The maximum permissible stress in the test specimen due to initial force (preload) shall not exceed 25 % of the mean strength. For four-point loading, make sure the fixture pivots or articulates so that all four loading rollers are in contact with the test specimen. A lamp or flashlight held behind the fixture can aid this examination.

8.5 Once preloaded, mark the front of the test specimen to identify the points of load application. Also mark the rod orientation so that the tensile and compression regions can be distinguished. Carefully drawn pencil or felt tip permanent marker pen marks will suffice. These marks assist in post fracture interpretation and analysis.

8.5.1 Specimens with noticeably elliptical cross sections (the ratio of the minor to major axis length is less than 0.95) should be positioned so that the major diameter is either approximately vertical or approximately horizontal in the fixture at the discretion of the user. Avoid positioning elliptical specimens at odd orientations in the fixture. A consistent alignment procedure should be used.

8.6 Put cotton, crumpled tissues, or other appropriate material around the test specimen to prevent pieces from flying out of the fixtures upon fracture. This step may help ensure operator's safety and preserve primary fracture pieces for subsequent fractographic analysis. A box or shield around the fixtures may also help ensure operator safety.

8.7 *Strain Rates*—The crosshead rates are chosen so that the strain rate upon the test specimen shall be approximately $1.0 \times 10^{-4} \text{ s}^{-1}$ (0.006 min^{-1}).

8.7.1 The strain rate for either the three- or four-point- $\frac{1}{4}$ point mode of loading is as follows:

$$\dot{\epsilon} = 6\dot{y}D/L_o^2 \quad (1)$$

and, therefore:

$$\dot{y} = \dot{\epsilon}L_o^2/6D = 0.006L_o^2/6D \quad (2)$$

where:

$\dot{\epsilon}$ = strain rate, min^{-1} ,
 D = specimen diameter, mm,
 \dot{y} = crosshead speed, mm/min, and
 L_o = outer (support span), mm.

NOTE 10—Example: A 3-mm diameter rod on a 20 by 40 mm fixture. $\dot{\epsilon} = 0.006 \text{ min}^{-1} * (40 \text{ mm})^2 / 6 * 3 \text{ mm} = 0.53 \text{ mm/min}$. Use a $\dot{y} = 0.5 \text{ mm/min}$. The calculation above assumes that most of the crosshead travel is imposed onto the specimen as discussed in 6.6.

8.7.2 Times to failure for typical ceramics will range from 3 to 30 s. It is assumed that the fixtures are relatively rigid and that most of the testing-machine crosshead travel is imposed as strain on the test specimen in accordance with section 6.6. If the times to failure are longer than 30 s, then faster rates may be used.

8.7.3 If it is suspected that slow crack growth is active to a degree that it might cause a rate dependency of the measured flexural strength, then faster testing rates should be used.

NOTE 11—The sensitivity of flexural strength to stressing rate may be assessed by testing at two or more rates. See Test Method C1368.

8.7.4 The strain rate may be converted to a stressing rate, assuming the material remains linearly elastic to fracture, by:

$$\dot{\sigma} = E\dot{\epsilon} \quad (3)$$

where:

- $\dot{\epsilon}$ = strain rate, s^{-1} ,
- $\dot{\sigma}$ = stressing rate, MPa/s, and
- E = elastic modulus, GPa.

NOTE 12—Example: A 3-mm diameter alumina rod ($E = 380$ GPa) on a 20 by 40 mm fixture with $\dot{y} = 0.5$ mm/min. The strain rate is $1 \times 10^{-4} s^{-1}$, so stressing rate = $380 \text{ GPa} * 1 \times 10^{-4} / s = 38 \text{ MPa/s}$.

8.8 If there is an excessive tendency for fractures to occur directly (within 0.5 mm) underneath a four-point flexure inner roller, then check the fixture alignment and articulation.

NOTE 13—Secondary fractures often occur at the four-point inner rollers and are harmless. See Annex A3.

NOTE 14—Occasional breaks outside the inner gage section in four-point fracture are not unusual, particularly for materials with low Weibull moduli (large scatter in strengths). These fractures can often be attributed to atypical, large natural flaws in the material. See Fig. A3.2.

NOTE 15—Breaks away from the middle loading roller in three-point loading are not unusual, especially for materials with low Weibull moduli. They often are due to large flaws.

8.9 *Break Force*—Measure the break force with an accuracy of ± 1.0 %.

8.10 *Validity Check*—If fixtures without cradles are used, verify that the specimens do not break at a loading point as a result of contact crack damage.

8.10.1 If specimens fracture from contact damage, then discard the result. If this occurs in only a few instances, the other test data may be satisfactory. If all specimens fracture from contact damage, then suspend the testing. Use a longer span fixture, or smaller diameter specimens, or use cradles with the fixtures. See Annex A1.

8.10.2 Verify that the test specimen breakage locations are dispersed in the inner gage section. See Annex A3.

8.10.3 Specimens which break outside of the inner gage section are valid in this test method provided that their occurrence is infrequent. See Annex A3 for guidance as to where the primary fracture is located. Frequent breakages outside their inner gage section (~10 % or more of the specimens) or frequent primary breakages directly under (within 0.5 mm) an inner roller are grounds for rejection of a test set. The specimens and fixtures should be checked for alignment and articulation.

NOTE 16—Breaks outside the inner gage section sometimes occur due to an abnormally large flaw and there may be nothing wrong with such a test outcome. The frequency of fractures outside the inner gage section depends upon the Weibull modulus and are more likely with low moduli, or if there are multiple flaw populations, or if there are stray flaws. Breakages directly under an inner load pin sometimes occur for similar reasons. In addition, many apparent fractures under a load pin are in fact legitimate fractures from an origin close to, but not directly at the load pin. Secondary fractures in specimens that have a lot of stored elastic energy (that is, strong specimens) often occur right under a load pin due to elastic

wave reverberations in the specimen. See Annex A3 for guidance.

8.10.4 Reject all specimens that fracture from scratches or other extraneous damage.

8.11 *Preserve Fragments*—All primary fracture fragments should be retained and preserved for fractographic analysis. Fractographic analysis of broken test specimens is highly recommended to characterize the types, locations, and sizes of fracture origins as well as possible stable crack extension due to slow crack growth. Follow the guidelines in Practice C1322. The test pieces may be retrieved with tweezers after fracture. The operator may wear gloves in order to avoid contamination of the fracture surfaces for possible fractographic analysis. If there is any doubt, then all pieces should be preserved.

8.12 *Test Specimen Dimensions*—Determine the diameter of each test specimen in the mid region to within 0.002 mm (or 0.0001 in.). Use a micrometer as specified in 6.7. It is recommended that measurement be made after the test specimen has been broken. Measure at a point near the fracture origin. Measurements should be made after the specimen is broken in order to avoid damage to the specimen prior to the test and also to eliminate any potential complications associated with variations in the diameter along the test specimen length. Take multiple readings (at least two) at different orientations around the periphery at the cross section near the origin and use an average diameter. Alternately, measurements may be made before the specimen is broken, but care should be taken to avoid damaging the test specimen.

8.12.1 If the test specimens have a noticeably elliptical cross section (the ratio of the minor to major axis length is less than 0.95), measure the major and minor diameters. These should have been aligned with the test fixture and the direction of load application in accordance with 8.5.1. The alignment can be confirmed by the surface markings applied to the specimen, or by observation of the location on the compression curl on the fracture surface.

8.13 *Relative Humidity*—Determine the relative humidity in accordance with Test Method E337.

9. Calculation or Interpretation of Results

9.1 The formula for the strength of a cylindrical rod in four-point flexure is:

$$\sigma = \frac{16Pa}{\pi D^3} \quad (4)$$

where:

- σ = strength in MPa (MN/m^2),
- P = break force, N,
- a = moment arm, mm, and
- D = specimen diameter, mm.

9.1.1 The moment arm a is the distance between an inner loading point and an outer support point:

$$a = \frac{L_o - L_i}{2} \quad (5)$$

where:

- L_i = inner (loading) span, mm, and
- L_o = outer (support) span, mm.

9.1.2 Thus, the formula for the strength of a cylindrical rod in four-point-1/4 point flexure is:

$$\sigma = \frac{4PL_o}{\pi D^3} \quad (6)$$

9.2 The formula for the strength of a cylindrical rod in three-point flexure is:

$$\sigma = \frac{8PL_o}{\pi D^3} \quad (7)$$

9.3 Eq 4, Eq 6, and Eq 7 may be used for test specimens that have elliptical cross sections provided that the ratio of minor to major axis diameter is between 0.95 and 1.0. If an average diameter is used in these equations (see 8.12), the error in stress is less than 2.5 %.

9.3.1 If the ratio of the minor to major axis diameter is less than 0.95, then measure the major and minor diameters and use them separately to compute the flexure stress in accordance with Eq 8 and Eq 9. The orientation of the test specimen in the fixtures was marked after the specimen was mounted in the fixture as per 8.5. Either the major or the minor axis was aligned with the direction of load application. The formula for the strength of an elliptical rod in four-point-1/4 point flexure is:

$$\sigma = \frac{4PL_o}{\pi D_{horiz} D_{vert}^2} \quad (8)$$

where:

D_{horiz} = test specimen diameter measured horizontally, mm, and

D_{vert} = test specimen diameter measured vertically, in the direction of the loading axis, mm.

NOTE 17—The minor or major test specimen axes may be mounted either flat or vertically in the fixture at the discretion of the user. See 8.5.1.

9.4 The formula for the strength of an elliptical cross section rod in three-point flexure is:

$$\sigma = \frac{8PL_o}{\pi D_{horiz} D_{vert}^2} \quad (9)$$

9.5 Eq 4, Eq 6, Eq 7, Eq 8, or Eq 9 shall be used for reporting the flexural strength.

NOTE 18—These equations give the maximum stress in the rod in bending. They do not necessarily give the stress that was acting upon the flaw at the fracture origin. In some cases, for example, for fracture mirror analysis or fracture toughness calculations, the stress should be corrected for subsurface origins, breaks partway up the sides of the rod, and breaks outside the inner span-gage section. For conventional Weibull analysis, always use the maximum stress in the test specimen at failure.

NOTE 19—The conversion between pounds per square inch (psi) and megapascals (MPa) is included for convenience (145.04 psi = 1 MPa; therefore, 100 000 psi = 100 ksi = 689.5 MPa).

10. Report

10.1 Test reports shall include the following:

10.1.1 Test configuration and nominal specimen size used. Average ellipticity ratio, or ellipticity range, if the test specimens are not round.

10.1.2 The number of specimens (n) used.

10.1.3 All relevant material data including vintage data or billet identification data if available. (Did all specimens come from one billet or batch?) As a minimum, the date the material was manufactured shall be reported.

10.1.4 Exact method of specimen preparation, including all stages of machining if available.

10.1.5 Heat treatments or exposures, if any.

10.1.6 Test environment including humidity (Test Method E337) and temperature.

10.1.7 Strain rate or crosshead rate and the typical time to fracture.

10.1.8 Report the strength of every specimen in megapascals (pounds per square inch) to three significant figures.

10.1.9 Mean ($\bar{\sigma}$) and standard deviation (SD) where:

$$\bar{\sigma} = \frac{\sum_1^n \sigma_i}{n} \quad (10)$$

$$SD = \sqrt{\frac{\sum_1^n (\sigma_i - \bar{\sigma})^2}{(n - 1)}} \quad (11)$$

10.1.10 Report of any deviations and alterations from the procedures described in this test method.

10.1.11 The following notation may be used to report the mean strengths:

$\bar{\sigma}_{(R,N,L)}$ denotes rod , R, (or "round") strengths measured in (N = 4 or 3) -point flexure, and (L = 20, 40, or 80 mm) fixture outer span size.

Examples:
 $\bar{\sigma}_{(R,4,40)} = 491$ MPa denotes the mean rod flexural strength was 491 MPa when measured in four-point flexure with 40 mm span fixtures.

$\bar{\sigma}_{(R,3,20)} = 707$ MPa denotes the mean rod flexural strength was 707 MPa when measured in three-point flexure with 20 mm span fixtures.

10.1.12 The relative humidity or test environment may also be reported as follows:

$\bar{\sigma}_{(R,N,L)} = XXX$ [RH % or environment] denotes rod strengths measured in an atmosphere with RH % relative humidity or other environment.

Examples:
 $\bar{\sigma}_{(R,4,40)} = 388$ MPa [45 %] denotes the mean rod flexural strength was 388 MPa when measured in four-point flexure with 40 mm span fixtures in lab ambient conditions with 45 % relative humidity.

$\bar{\sigma}_{(R,3,40)} = 705$ MPa [dry N₂] denotes the mean flexural strength was 705 MPa when measured in three-point flexure with 40 mm span fixtures in a dry nitrogen gas environment.

$\bar{\sigma}_{(R,3,20)} = 705$ MPa [vacuum] denotes the mean flexural strength was 705 MPa when measured in three-point flexure with 20 mm span fixtures in a vacuum environment.

11. Precision and Bias

11.1 The flexure strength of a ceramic is not a deterministic quantity, but will vary from one specimen to another. There will be an inherent statistical scatter in the results for finite sample sizes (for example, 30 test specimens). Weibull statistics can model this variability as discussed in Practice C1239. This test method has been devised so that the precision is very high and the bias very low compared to the inherent variability of strength of the material.

11.2 The experimental errors in the flexure test in general have been analyzed and documented in Ref (1). Many of the misalignment errors (inner span versus outer span in four-point, or middle loading point in three-point, span size errors) are the same for rod specimens as for rectangular specimens. The specifications and tolerances in this test method have been

chosen such that the individual errors are typically a maximum of 0.5 % to 1.0 % each. An exception is the wedging stress error described in 11.5 which can be as large as 5 % to 10 % if fixtures without cradles are used as discussed in 11.5.1. If cradles are used in four point-loading, the total error is probably less than 3 % for four-point configurations B and C. This is the maximum possible error in stress for an individual specimen.

11.3 The small four-point configuration A is somewhat more prone to error which is probably greater than 5 % in four-point loading. The error is less for the small three-point A configuration, but this configuration exposes only a tiny portion of the material to the full tensile stress and is subject to the wedging stress error. For this reason, the A configurations are not recommended for design purposes, but only for characterization and materials development.

11.4 Three-point loading errors for common fixture misalignments are typically less than for four-point flexure loading. An important exception is for the case of three-point loading of very short length, but large diameter rods, in which case wedging stress errors can be very significant as described in 11.5. In addition, since only a small region of the test specimen is exposed to high stress, the three-point loading configuration is usually not recommended.

11.5 Wedging stress errors are created by the concentrated forces at the loading points. The crossed cylinders arrangement can create stress field distortions in the immediate vicinity of the load application points, including the opposite side of the test specimen. These stress field distortions are worse for rods loaded in bend fixtures with crossed cylindrical contacting rollers than for rectangular bend bars in similar test fixtures. Wedging stress errors are eliminated by the use of cradles as per section 6.5.

11.5.1 For crossed cylinder arrangements (rod specimen on rollers), the wedging errors in maximum tensile stress range can cause errors as high as +10 % for some of the configurations allowed in this method. The errors are largest for the lowest L_0/D ratios. They are minimized by use of large L_0/D

ratios. The localized wedging errors are the same for the three-point and four-point configurations in this method. The errors are very localized, however, and only exist in the immediate vicinity of the loading points. The errors are of greater concern for the three-point loading configuration than for the four-point configuration, since the errors in the latter are mitigated by the large amount of unaffected material in the gage section.

11.5.2 Despite the large wedging stress errors (from the crossed cylinder configuration) identified in 11.5.1, analysis has shown that their net effect upon the Weibull characteristic strength for a set of specimens is much smaller. It ranges from ~0 to +5 % for the configurations in this standard. The error is very small for the four-point configurations and ranges from 0 to +5 % for the three-point configurations. The reason for this is that the wedging stress errors are positive in some locations near the loading points and negative in other nearby locations. The net effect on the risk of rupture, the effective volume, the effective surface, the Weibull modulus, and characteristic strength, has been analyzed and described in Ref (7). This mitigation of a known stress error upon the final result (in this case, the calculated Weibull parameters) is unusual and specific to materials such as ceramics and glasses which break in accordance with Weibull theory and not simply from the maximum stress in a body. Other materials, such as metals and plastics will be subject to the full wedging stress error described in 11.5.1.

11.6 The error due to contact point tangency shift, from the loading point shifting on a loading roller as the specimen deflects, is a maximum of +0.4 % for materials with a strength to elastic modulus ratio of 1000, if the requirements of 6.4.6 are met.

11.7 Interlaboratory comparisons of rod flexure strength are not yet available.

12. Keywords

12.1 advanced ceramics; cylinder; flexural strength; four-point flexure; glass; rods; three-point flexure

ANNEXES

(Mandatory Information)

A1. CONTACT CRACKS IN RODS TESTED WITH ROLLERS

A1.1 Contact cracks may form at the loading and support points when rods are tested using loading rollers. This is especially of concern in true for configurations with low L_0/D ratios. Fig. A1.1 shows an example in a glass rod. If small, they may be harmless and do not disturb the stress distribution in the specimen or cause premature fracture. Fig. A1.2 shows a fracture surface of a glass rod that had a valid fracture in 3-point loading from an origin near the rod bottom. A contact

crack is evident on the opposite (top) side of the specimen. The contact crack exists in the region that normally has the compression (or cantilever curl) of a fractured rod broken in bending.

A1.2 Contact cracks can cause premature fracture if they get too large or reach tensile-stressed portions of the rod. Figs. A1.3 and A1.4 show examples.