



International
Standard

ISO 11452-3

**Road vehicles — Component test
methods for electrical disturbances
from narrowband radiated
electromagnetic energy —**

**Part 3:
Transverse electromagnetic
(TEM) cell**

*Véhicules routiers — Méthodes d'essai d'un équipement soumis
à des perturbations électriques par rayonnement d'énergie
électromagnétique en bande étroite —*

Partie 3: Cellule électromagnétique transverse (TEM)

**Fourth edition
2024-05**

iTeh Standards
(<https://standards.iteh.ai>)
Document Preview

[ISO 11452-3:2024](https://standards.iteh.ai/catalog/standards/iso/64ae42e2-d5c4-49dd-a0b2-d081ef66b8de/iso-11452-3-2024)

<https://standards.iteh.ai/catalog/standards/iso/64ae42e2-d5c4-49dd-a0b2-d081ef66b8de/iso-11452-3-2024>



COPYRIGHT PROTECTED DOCUMENT

© ISO 2024

All rights reserved. Unless otherwise specified, or required in the context of its implementation, no part of this publication may be reproduced or utilized otherwise in any form or by any means, electronic or mechanical, including photocopying, or posting on the internet or an intranet, without prior written permission. Permission can be requested from either ISO at the address below or ISO's member body in the country of the requester.

ISO copyright office
CP 401 • Ch. de Blandonnet 8
CH-1214 Vernier, Geneva
Phone: +41 22 749 01 11
Email: copyright@iso.org
Website: www.iso.org

Published in Switzerland

Contents

	Page
Foreword	iv
Introduction	v
1 Scope	1
2 Normative references	1
3 Terms and definitions	1
4 Test conditions	1
5 Test apparatus	2
5.1 TEM cell.....	2
5.2 Instrumentation.....	3
5.3 Test set-up.....	4
5.3.1 General.....	4
5.3.2 Exposure of device under test and wiring harness (for major field coupling to the harness).....	4
5.3.3 Exposure of device under test alone (for major field coupling to that device).....	5
6 Test procedure	6
6.1 Test plan.....	6
6.2 Test method.....	7
6.2.1 General.....	7
6.2.2 Test level setting.....	7
6.2.3 DUT test.....	8
6.3 Test report.....	8
Annex A (informative) TEM cell dimensions	9
Annex B (informative) Calculations and measurements of TEM-cell frequency range	11
Annex C (informative) Installation of external components and low pass filter design	13
Annex D (informative) Test setup without low pass filters	16
Annex E (informative) Function performance status classification (FPSC) and test severity levels	20
Bibliography	21

Foreword

ISO (the International Organization for Standardization) is a worldwide federation of national standards bodies (ISO member bodies). The work of preparing International Standards is normally carried out through ISO technical committees. Each member body interested in a subject for which a technical committee has been established has the right to be represented on that committee. International organizations, governmental and non-governmental, in liaison with ISO, also take part in the work. ISO collaborates closely with the International Electrotechnical Commission (IEC) on all matters of electrotechnical standardization.

The procedures used to develop this document and those intended for its further maintenance are described in the ISO/IEC Directives, Part 1. In particular, the different approval criteria needed for the different types of ISO document should be noted. This document was drafted in accordance with the editorial rules of the ISO/IEC Directives, Part 2 (see www.iso.org/directives).

ISO draws attention to the possibility that the implementation of this document may involve the use of (a) patent(s). ISO takes no position concerning the evidence, validity or applicability of any claimed patent rights in respect thereof. As of the date of publication of this document, ISO had not received notice of (a) patent(s) which may be required to implement this document. However, implementers are cautioned that this may not represent the latest information, which may be obtained from the patent database available at www.iso.org/patents. ISO shall not be held responsible for identifying any or all such patent rights.

Any trade name used in this document is information given for the convenience of users and does not constitute an endorsement.

For an explanation of the voluntary nature of standards, the meaning of ISO specific terms and expressions related to conformity assessment, as well as information about ISO's adherence to the World Trade Organization (WTO) principles in the Technical Barriers to Trade (TBT), see www.iso.org/iso/foreword.html.

This document was prepared by Technical Committee ISO/TC 22, *Road vehicles*, Subcommittee SC 32, *Electrical and electronic components and general system aspects*.

This fourth edition cancels and replaces the third edition (ISO 11452-3:2016), of which it constitutes a minor revision. The changes are as follows:

— [Formula \(1\)](#) in [6.2.2](#) was modified.

A list of all parts in the ISO 11452 series can be found on the ISO website.

Any feedback or questions on this document should be directed to the user's national standards body. A complete listing of these bodies can be found at www.iso.org/members.html.

Introduction

Immunity measurements of complete road vehicles are generally able to be carried out only by the vehicle manufacturer, owing to, for example, high costs of absorber-lined shielded enclosures, the desire to preserve the secrecy of prototypes or a large number of different vehicle models.

For research, development and quality control, a laboratory measuring method can be used by both vehicle manufacturers and equipment suppliers to test electronic components.

The TEM cell method has the major advantage of not radiating energy into the surrounding environment. The method can be used for testing either the immunity of a component with the field coupling to the wiring harness or the immunity of the component alone with minimum exposure to the wiring harness.

iTeh Standards (<https://standards.iteh.ai>) Document Preview

[ISO 11452-3:2024](https://standards.iteh.ai/catalog/standards/iso/64ae42e2-d5c4-49dd-a0b2-d081ef66b8de/iso-11452-3-2024)

<https://standards.iteh.ai/catalog/standards/iso/64ae42e2-d5c4-49dd-a0b2-d081ef66b8de/iso-11452-3-2024>

Road vehicles — Component test methods for electrical disturbances from narrowband radiated electromagnetic energy —

Part 3: Transverse electromagnetic (TEM) cell

1 Scope

This document specifies transverse electromagnetic (TEM) cell tests for determining the immunity of electronic components of passenger cars and commercial vehicles to electrical disturbances from narrowband radiated electromagnetic energy, regardless of the vehicle propulsion system (e.g. spark-ignition engine, diesel engine, electric motor).

The electromagnetic disturbances considered are limited to continuous narrowband electromagnetic fields.

2 Normative references

The following documents are referred to in the text in such a way that some or all of their content constitutes requirements of this document. For dated references, only the edition cited applies. For undated references, the latest edition of the referenced document (including any amendments) applies.

ISO 11452-1, *Road vehicles — Component test methods for electrical disturbances from narrowband radiated electromagnetic energy — Part 1: General principles and terminology*

3 Terms and definitions

For the purposes of this document, the terms and definitions given in ISO 11452-1 apply.

ISO and IEC maintain terminology databases for use in standardization at the following addresses:

- ISO Online browsing platform: available at <https://www.iso.org/obp>
- IEC Electropedia: available at <https://www.electropedia.org/>

4 Test conditions

The upper frequency range limit of the TEM cell is a direct function of the TEM cell dimensions.

For testing automotive electronic systems, a 0,01 MHz to 200 MHz TEM cell should be used. See [Annex A](#) for suggested cell dimensions. See [Annex B](#) for methods to determine TEM-cell frequency range.

The user shall specify the test severity level or levels over the frequency range. See [Annex E](#) for suggested test severity levels.

Standard test conditions shall be those given in ISO 11452-1 for:

- test temperature;
- supply voltage;

- modulation;
- dwell time;
- frequency step sizes;
- definition of test severity levels;
- test-signal quality.

5 Test apparatus

5.1 TEM cell

The TEM cell used for this test is a rectangular coaxial line with a 50 Ω characteristic impedance (see [Figure 1](#)). The device under test is exposed to a uniform TEM field.

The TEM cell is a laboratory measurement system which can be used to generate test fields within 2 dB of the theoretical value if the device under test does not occupy an excessive portion of the test volume (see [5.3](#)).

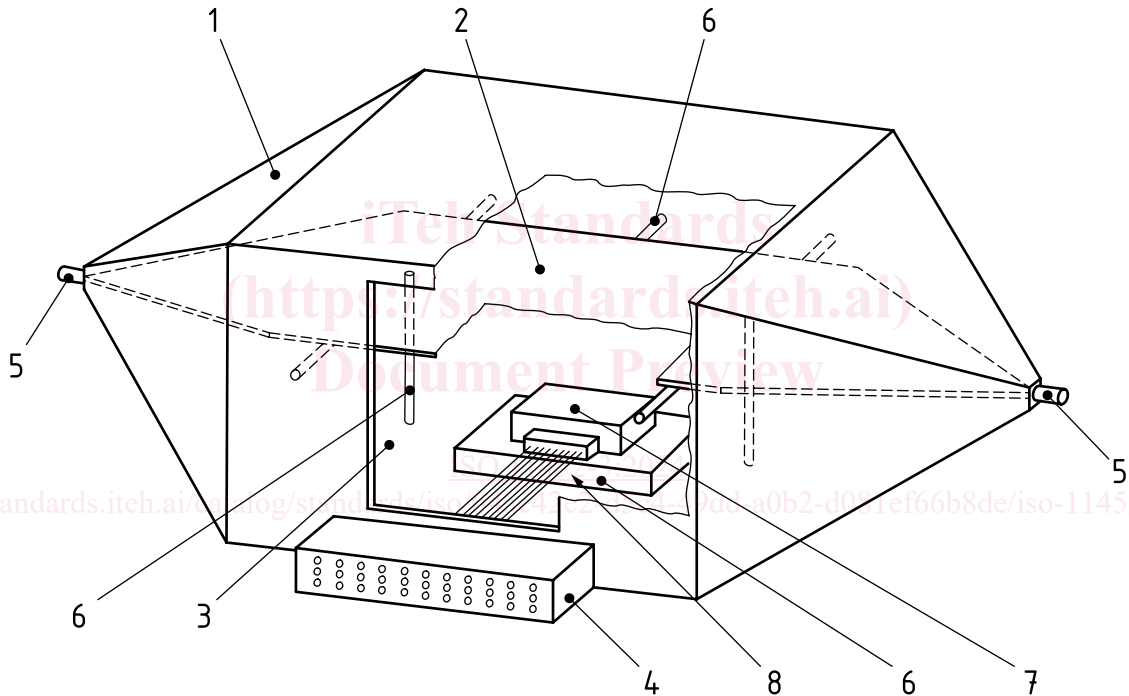

Key

- 1 outer conductor (shield)
- 2 septum (inner conductor)
- 3 access door
- 4 connector panel (optional)
- 5 coaxial connectors
- 6 dielectric support (relative permittivity $\epsilon_r \leq 1,4$)
- 7 device under test
- 8 input/output leads

Figure 1 — TEM cell

5.2 Instrumentation

Figure 2 shows an example of a TEM cell test set-up. The TEM cell has high resonances in the region greater than the recommended upper frequency limit.

A low pass filter with an attenuation of at least 60 dB at frequencies above 1,5 times the cut-off frequency of the TEM cell may be installed (e.g. 200 MHz TEM cell: 60 dB for frequencies above 300 MHz) to avoid resonances.

Example of installation of low pass filter is given in Annex C.

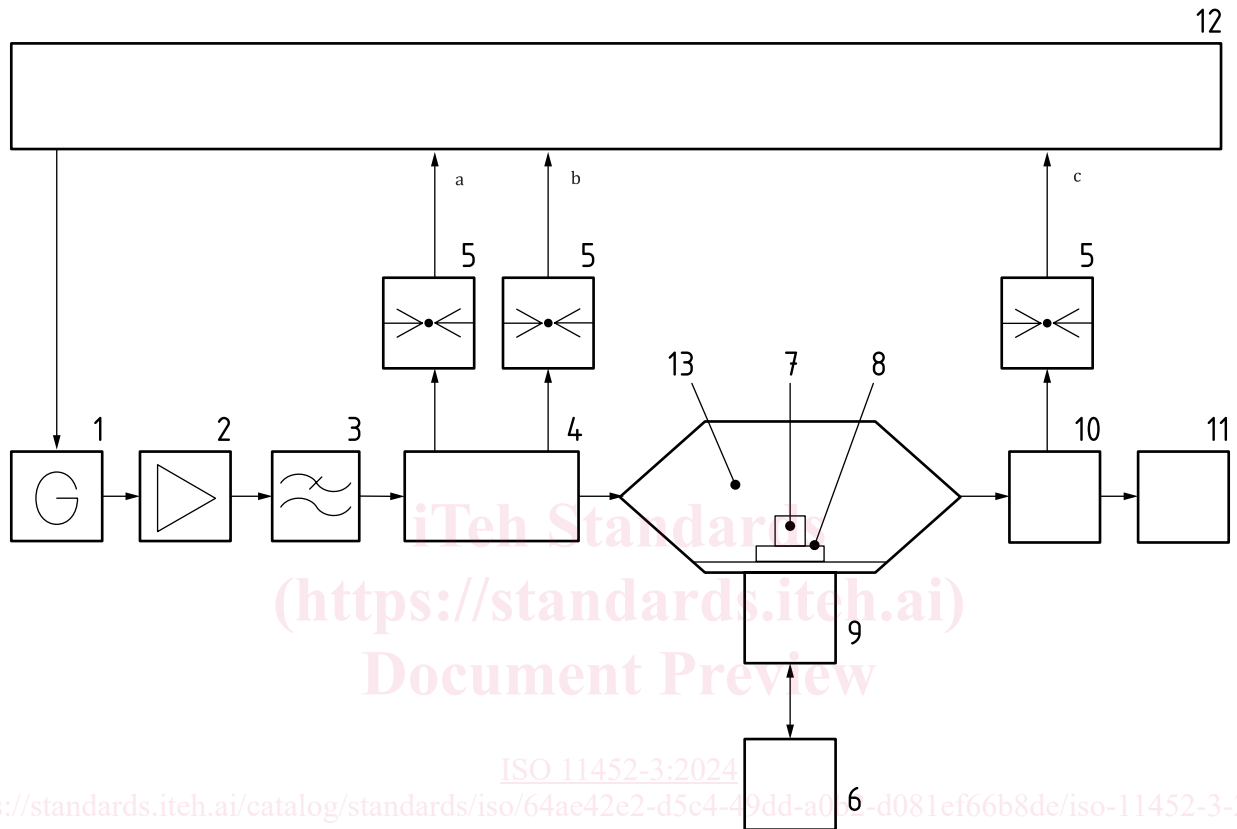

Key

- | | | | |
|---|---|----|---|
| 1 | signal generator | 9 | low pass filters/connector panel |
| 2 | broadband amplifier | 10 | coupler |
| 3 | low pass filter (optional) | 11 | high power load (50 Ω) |
| 4 | dual-directional coupler (30 dB decoupling ratio minimum) | 12 | controller |
| 5 | RF-power meter | 13 | TEM cell |
| 6 | peripheral | a | P_{forward} (forward power). |
| 7 | device under test | b | $P_{\text{reflected}}$ (reflected power). |
| 8 | dielectric support | c | P_{output} (output power). |

Figure 2 — Example TEM cell configuration

5.3 Test set-up

5.3.1 General

In order to maintain the homogeneous field in the TEM cell and obtain reproducible measurement results, the device under test shall be no larger than one-sixth of the cell (inside) height b (see [Figure 3](#) and [Figure A.1](#)). The device under test should be placed in the centre of the cell on a dielectric equipment support.

The device under test and the wiring harness may be positioned in either of two arrangements, depending on whether the exposure of the device under test and the wiring harness (see [5.3.2](#)) or that of the device alone (see [5.3.3](#)) is being tested.

An alternative test set-up without low pass filter is presented in [Annex D](#).

5.3.2 Exposure of device under test and wiring harness (for major field coupling to the harness)

The height of the dielectric support is one-sixth of cell height b (see [Figure 3](#)). In order to obtain reproducible measurement results, the device under test, together with its wiring harness or printed circuit board, shall be placed in the same position in the TEM cell for each measurement. In addition to the direct RF-field coupling to the device under test, the use of an unshielded harness or printed circuit board will result in a common mode electrical field coupling and a differential mode magnetic field coupling, depending on the inclination and the width of the harness or circuit board.

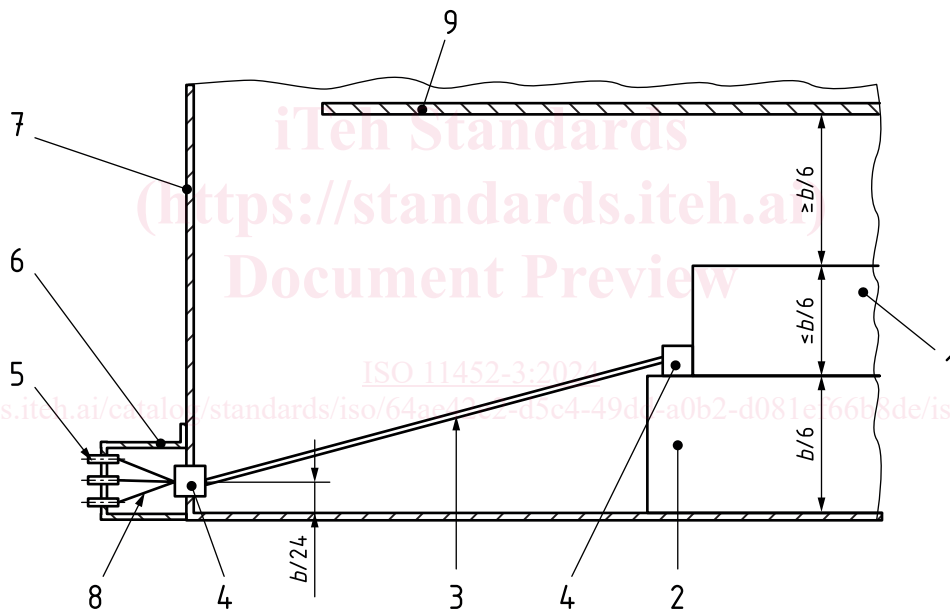

Key

- 1 device under test
- 2 dielectric support (relative permittivity $\epsilon_r \leq 1,4$)
- 3 printed circuit board (no ground plane) or wiring harness, unshielded
- 4 connector
- 5 coaxial connectors
- 6 connector panel
- 7 TEM cell wall
- 8 cables
- 9 septum
- b TEM cell height (see [Annex A](#))

Figure 3 — Example test set-up — Major field coupling to wiring harness (side view)