



Designation: **B820—09 B820 – 14**

# Standard Test Method for Bend Test for Determining the Formability of Copper and Copper Alloy Strip<sup>1</sup>

This standard is issued under the fixed designation B820; the number immediately following the designation indicates the year of original adoption or, in the case of revision, the year of last revision. A number in parentheses indicates the year of last reapproval. A superscript epsilon ( $\epsilon$ ) indicates an editorial change since the last revision or reapproval.

## 1. Scope\*

1.1 This test method describes the technique of bend testing copper and copper alloy strip samples to determine product formability or the ability to resist cracking when forming a bend around a specific radius. The criterion for failure is the occurrence of cracks on the outer radius of curvature (convex).

1.2 This bend test is limited to strip from 0.003 to and including 0.031 in. thick. (0.076 to and including 0.79 mm).

1.3 The size of the forming radii used in this test shall be 0.005 to and including 0.250 in. (0.127 to and including 6.35 mm).

1.4 *Units*—~~The values~~ Values stated in inch-pound units are to be regarded as standard. The values given in parentheses are mathematical conversions to SI units ~~that~~ which are provided for information only and are not considered standard.

1.5 *This standard does not purport to address all of the safety concerns, if any, associated with its use. It is the responsibility of the user of this standard to establish appropriate safety and health practices and determine the applicability of regulatory limitations prior to use.*

## 2. Referenced Documents

2.1 *ASTM Standards:*<sup>2</sup>

[B846 Terminology for Copper and Copper Alloys](#)

[B950 Guide for Editorial Procedures and Form of Product Specifications for Copper and Copper Alloys](#)

[E6 Terminology Relating to Methods of Mechanical Testing](#)

[E290 Test Methods for Bend Testing of Material for Ductility](#)

## 3. Terminology

3.1 *Definitions*—For definitions of terms related to copper and copper alloys, refer to Terminology [B846](#), and for definitions of terms relating to mechanical testing, refer to Terminology [E6](#).

3.2 For definitions of terms related to mechanical testing, refer to Terminology [E6](#).

3.3 *Description of Terms Specific to This Standard:*

3.3.1 *bend, longitudinal (or good way bend)*—a bend with an axis perpendicular to the direction of rolling, drawing or extrusion (see [Fig. 1](#)).

3.3.2 *bend, transverse (or bad way bend)*—a bend with an axis on a plane parallel to the direction of rolling, drawing or extrusion (see [Fig. 1](#)).

NOTE 1—The usage of these two terms is consistent with Test Method/Methods [E290](#).

## 4. Summary of Test Method

4.1 The bend test is made by applying a force transversely to the length of the specimen in the portion being bent, usually at mid-length. The 90° bending forces are applied through an arrangement illustrated in [Fig. 2](#), while 180° bending forces are applied

<sup>1</sup> This test method is under the jurisdiction of ASTM Committee [B05](#) on Copper and Copper Alloys and is the direct responsibility of Subcommittee [B05.06](#) on Methods of Test.

Current edition approved April 1, 2009/April 1, 2014. Published May 2009/May 2014. Originally approved in 1992. Last previous edition approved in 1998/2009 as [B820—04](#)/[B820—09](#). DOI: [10.1520/B0820-09](#)/[10.1520/B0820-14](#).

<sup>2</sup> For referenced ASTM standards, visit the ASTM website, [www.astm.org](#), or contact ASTM Customer Service at [service@astm.org](#). For *Annual Book of ASTM Standards* volume information, refer to the standard's Document Summary page on the ASTM website.

\*A Summary of Changes section appears at the end of this standard

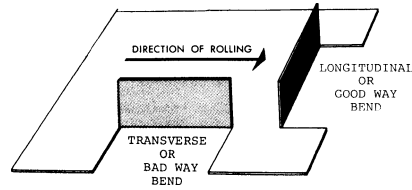

FIG. 1 — Direction of Bending

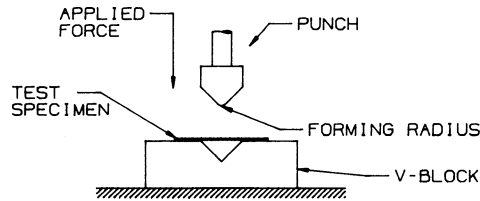

FIG. 2 — V-Block and Punch for 90° Bend Test

through an arrangement illustrated in Fig. 3. When complete fracture does not occur, the convex surface of the specimen is examined for cracks. In general, the test using a 180° bend angle is a more severe test than the test using a 90° bend angle.

**5. Significance and Use**

5.1 This bend test provides information as to the formability or the ability of copper and copper alloy strip to resist cracking when being formed.

5.2 This test method can be used as a quality control tool to determine if material will form to a given radius.

5.3 This test method is also useful in research and development to provide data for use in selecting a spring material that will safely form to the geometry of a given part.

5.4 The results are suitable for direct application in design and manufacturing, only when all factors such as the geometry of the part, punch and die design, lubrication, stamping speed, and other material properties are known.

**6. Apparatus**

6.1 Various devices are suitable for 90° or 180° bend testing. The apparatus shall provide these features:

6.1.1 *90° Bend Test Fixture*—An illustration of this test fixture is shown in Fig. 2. A specimen rests on a pair of pins, rollers, or radiused flat supports; a pin, mandrel, or 90° V-block punch of a given bend radius for applying the bending force directly at the mid-length.

6.1.2 *180° Bend Test Fixture*—An illustration of this test fixture is shown in Fig. 3. A specimen rests on a pair of pins, rollers, or radiused flat supports; a pin, mandrel, or 180° punch of a given bend radius for applying the bending force directly at the mid-length. Dial indicators with a precision of 0.0005 in. (0.013 mm) or better are necessary to accurately position the two supports.

6.1.2.1 To prevent breaking the punch, it is recommended not to use a radius smaller than 1/2 the thickness of the material being tested and in no case should the punch size be less than .005 in. (0.127 mm).

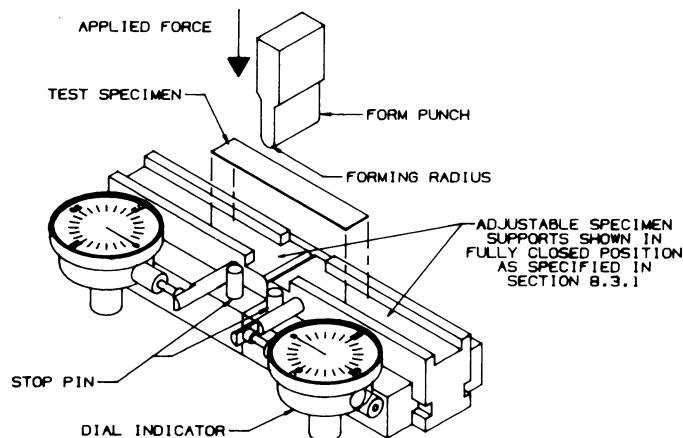

FIG. 3 — Fixture for 180° Bend Test