



Standard Practice for Preparing Tension Test Specimens for Copper Alloy Sand, Permanent Mold, Centrifugal, and Continuous Castings¹

This standard is issued under the fixed designation B208; the number immediately following the designation indicates the year of original adoption or, in the case of revision, the year of last revision. A number in parentheses indicates the year of last reappraisal. A superscript epsilon (ϵ) indicates an editorial change since the last revision or reappraisal.

This standard has been approved for use by agencies of the U.S. Department of Defense.

1. Scope*

1.1 This practice establishes procedures for preparing test coupons and specimens (machined and unmachined) for tension tests of copper alloys for sand, permanent mold, centrifugal and continuous castings.

1.2 The values stated in inch-pound units are the standard. ~~SI to be regarded as standard.~~ The values given in parentheses are for information only. ~~mathematical conversions to SI units that are provided for information only and are not considered standard.~~

2. Referenced Documents

2.1 *ASTM Standards:*²

B846 Terminology for Copper and Copper Alloys

3. Terminology

3.1 Definitions of terms relating to copper alloys can be found in Terminology **B846**.

4. Significance and Use

4.1 The mechanical properties determined from test bars for sand, permanent mold, and centrifugal castings poured in accordance with this practice represent the properties of the metal going into castings poured from the same heat. These mechanical properties may not be the same as the properties of the corresponding castings because of the solidification effects of varying size, section, and design.

4.2 Test bars for continuous castings are taken from the castings and therefore represent the properties of the castings.

5. Test Coupons

5.1 *Sand Castings*—The test bar coupons shall be made by the same manufacturing process as the castings they represent wherever possible. If the castings are cast entirely in green sand, partial cores shall be permitted for the test bars but in no case shall chills be permitted. Unless otherwise agreed upon between the manufacturer and purchaser, test bars may be poured in cores on a production line. The use of filters in the gating system is permitted.

5.1.1 *High-Shrinkage Sand-Cast Alloys*—The test specimen coupons for copper casting alloys exhibiting high shrinkage during freezing and cooling shall be cast to the form and dimensions shown in **Fig. 1** (a or b) or **2** (a or b). If specimens having threaded ends are to be used in the tension tests, the length of the keel blocks in **Fig. 1a** may be reduced to 6¹/₄ in. (159 mm). See **Appendix X1** for SI equivalents.

5.1.2 *Low-Shrinkage Sand-Cast Alloys*—The test specimen coupons for copper casting alloys exhibiting low shrinkage during freezing and cooling shall be cast to the form and dimensions shown in **Fig. 2** (A or B), **Fig. 3**, or **Fig. 4** or as may be prescribed in the casting specifications.

¹ This practice is under the jurisdiction of ASTM Committee **B05** on Copper and Copper Alloys and is the direct responsibility of Subcommittee **B05.05** on Castings and Ingots for Remelting.

Current edition approved Feb. 1, 2006/April 1, 2014. Published February 2006/May 2014. Originally approved in 1946. Last previous edition approved in 2004/2006 as **B208—04-B208 – 06**. DOI: 10.1520/B0208-06.10.1520/B0208-14.

² For referenced ASTM standards, visit the ASTM website, www.astm.org, or contact ASTM Customer Service at service@astm.org. For *Annual Book of ASTM Standards* volume information, refer to the standard's Document Summary page on the ASTM website.

*A Summary of Changes section appears at the end of this standard

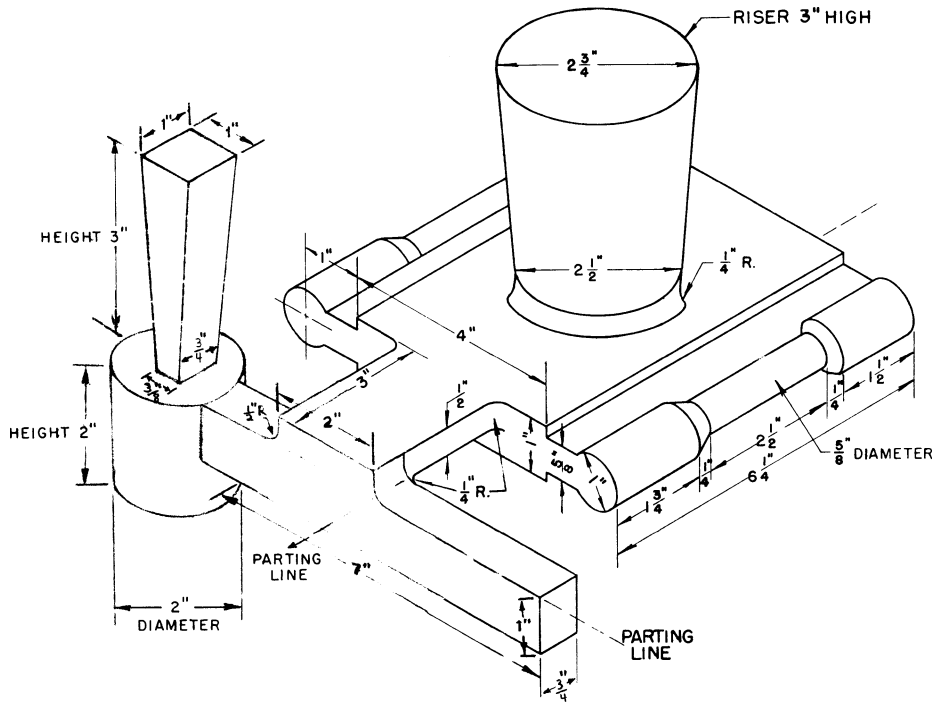

FIG. 2a — Double Horizontal Full-Web Type Test Bars

FIG. 2 a Double Horizontal Full-Web Type Test Bars

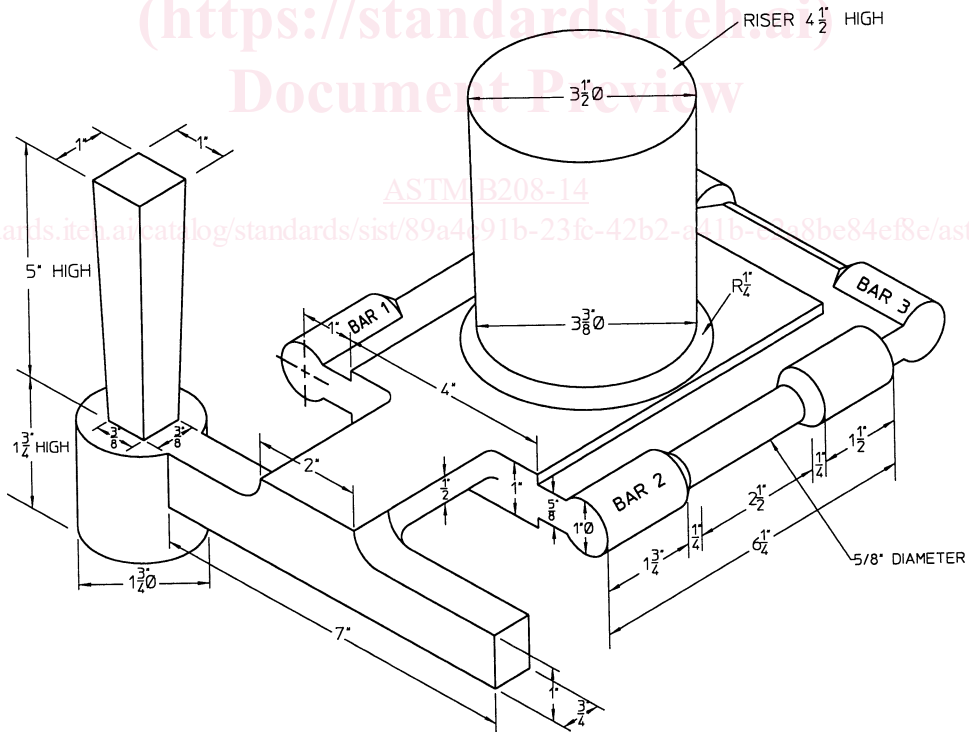
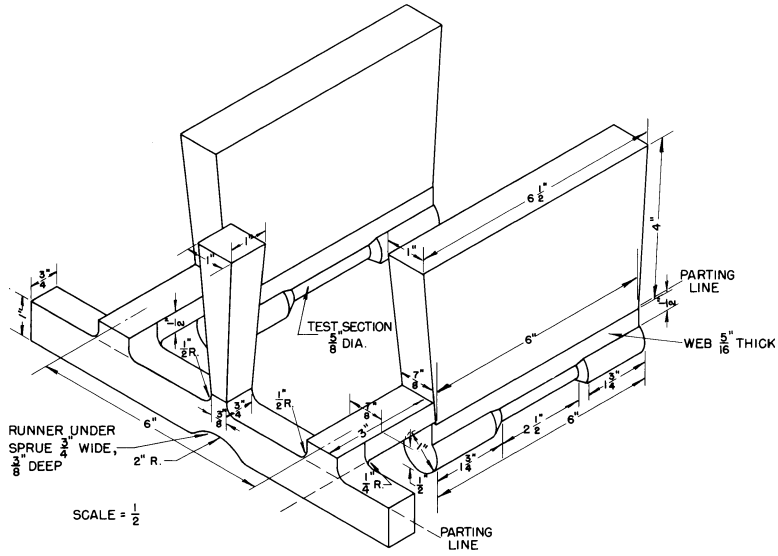
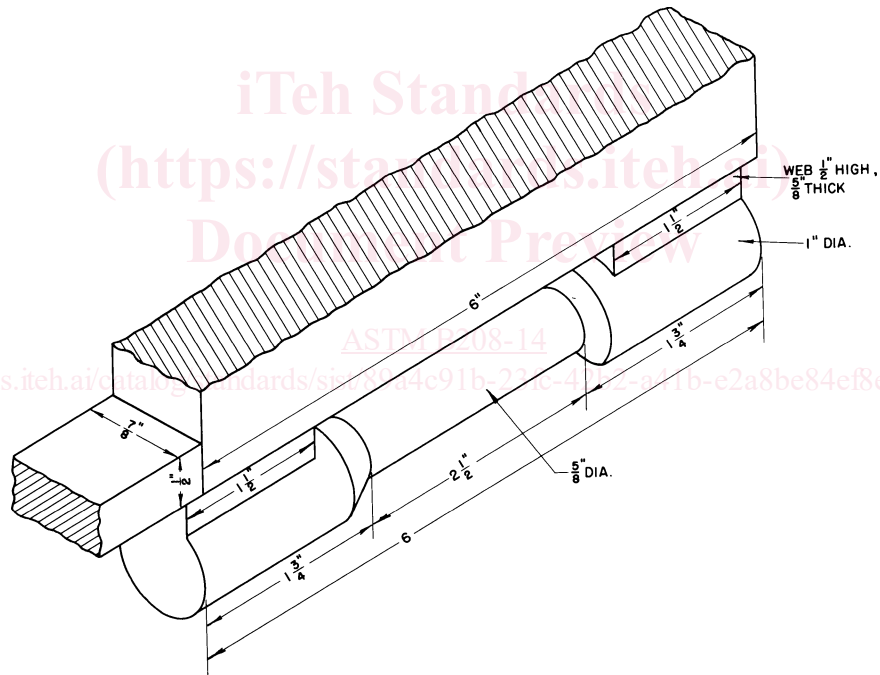

FIG. 2 b Triple Full-Web Type Test Bar



(a) Gating Design for Double Vertical Full-Web or Grip-Web Type Bars (Full-Web Bars Being Cast)

(a) Gating Design for Double Vertical Full-Web or Grip-Web Type Bars (Full-Web Bars Being Cast)



(b) Design of the Vertical Grip-Web Bar (Gating and Riser System as in (a))

FIG. 3 Double Vertical Full-Web and Grip-Web Type Test Bars

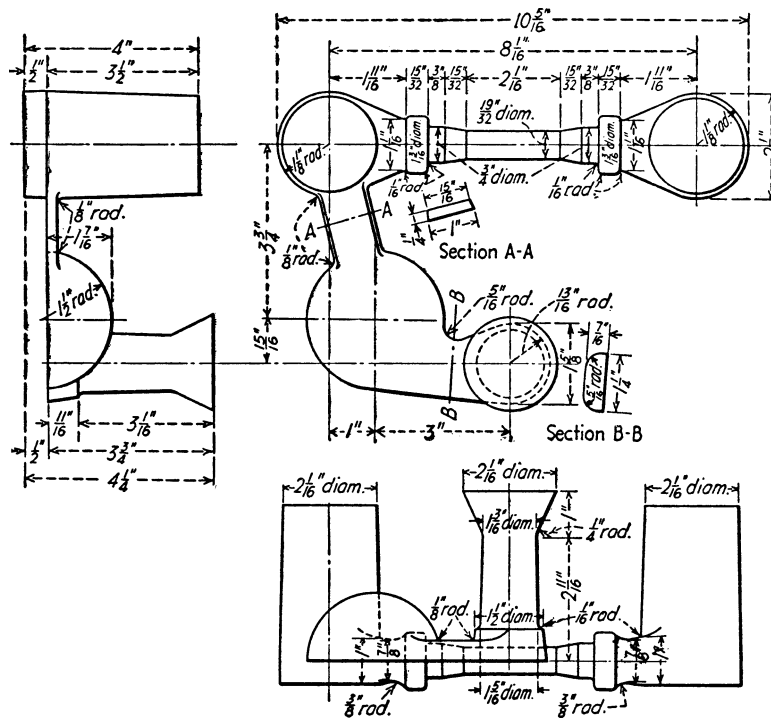

FIG. 4 Optional Coupon for As-Cast Tension Test Specimen, Button Head

5.2 *Centrifugal Castings*—Unless otherwise specified by the purchaser, the manufacturer shall pour the test bars in the same type of mold as the castings themselves. That is, test bars for sand mold castings shall be poured in sand molds, and test bars for chill mold castings shall be poured in chill molds.

5.2.1 The centrifugally cast test specimen coupons shall be cast to the form and dimensions of Fig. 5a.

5.2.2 Static test bar coupons shall be cast in open keel block molds as dimensioned in Fig. 5b.

5.3 *Continuous Castings*—Test bars shall be taken from the continuous cast product. Test bars may be taken before mechanical straightening.

5.3.1 Test bar coupons shall be taken in a longitudinal direction from the continuous cast product at the mid-wall of hollow castings or at one-half the distance between the center and the side of solid castings as illustrated in Fig. 6.

5.3.2 For irregular shapes, the location of the test bar coupon shall be as agreed upon between the manufacturer and purchaser.

5.3.3 Transverse test specimens are allowed for continuous cast product having a cross section thickness, diameter, or wall of 4 in. or more. The cross sections are the diameter of a round solid, the distance across flats of a solid hexagon, the thickness of a rectangle, and the wall thickness of a tube.

5.4 *Permanent Mold Castings*—The test bar coupons shall be made in the permanent die for test bars shown in Fig. 7 or Fig. 9. The runner, gate, and risers shall be coated with an insulating spray. The test bar cavity shall be coated with a graphite spray. Test bar casting shall be poured in the tilted position and rotated to the vertical position during pouring.

6. Test Specimens

6.1 *Sand Cast*—Tension test specimens shall be machined from the coupons described in 5.1.1 and 5.1.2 and shown in Fig. 1, Fig. 2, and Fig. 3. They shall be of the form and dimensions shown in Fig. 11 for the 0.500-in. standard test bar specimen.

6.1.1 In the case of test specimens prepared from the coupons in Fig. 4, the manufacturer shall have the option of testing the specimens without machining the gage length. If the specimens are machined, the gage length, parallel sections, and fillets shall be machined to the dimensions shown in Fig. 11.

6.2 *Centrifugally Cast*—Tension test specimens shall be machined from the coupons described in 5.2.1 and shown in Fig. 5. They shall be of the form and dimensions shown in Fig. 11.

6.3 *Continuous Cast*—Tension test specimens shall be machined from the continuous cast product as described in 5.3.1 and shown in Fig. 6. They shall be of the form and dimensions as shown in Fig. 11.

6.4 *Permanent Mold*—Tension test specimens shall be cut from the test bar coupon shown in Fig. 7 or Fig. 9 and shall be of the form and dimensions shown in Figs. 8 and 10.

NOTE 1—The dimensions for the die shown in Fig. 7 or Fig. 9 are “standard rule.” After solidification and cooling, a tension test specimen of the form and dimensions of Figs. 8 and 10 will be produced by the die shown in Fig. 7 or Fig. 9.

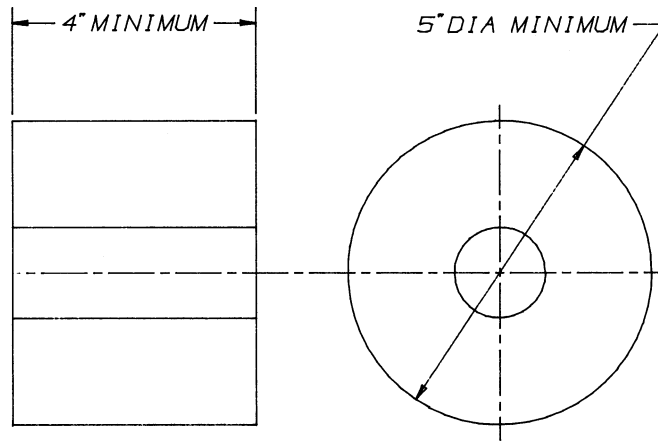

FIG. 5a—Centrifugal Cast Test Bar

FIG. 5 a Centrifugal Cast Test Bar

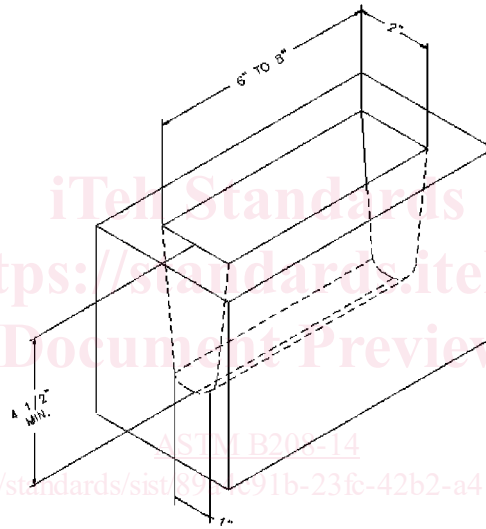

FIG. 5 b—Open Keel Block Test Bar

6.4.1 The gage length and reduced section shall be as cast, but the ends may be machined to fit the holders of the testing machine in such a way that the load shall be axial.

7. Keywords

7.1 copper alloys; copper alloy castings; tension test specimens