



Designation: ~~D3700~~—~~12~~ **D3700** – 14

Standard Practice for Obtaining LPG Samples Using a Floating Piston Cylinder¹

This standard is issued under the fixed designation D3700; the number immediately following the designation indicates the year of original adoption or, in the case of revision, the year of last revision. A number in parentheses indicates the year of last reapproval. A superscript epsilon (ϵ) indicates an editorial change since the last revision or reapproval.

1. Scope*

1.1 This practice covers the equipment and procedures for obtaining a representative sample of ~~specification~~ liquefied petroleum gas (LPG), such as specified in ASTM Specification **D1835**, GPA 2140, and comparable international standards. It may also be used for other natural gas liquid (NGL) products that are normally single phase (for example, NGL mix, field butane, and so forth), defined in other industry specifications or contractual ~~agreements~~ agreements, and for volatile (higher vapor pressure) crude oils.

1.2 This practice is not intended for non-specification products that contain significant quantities of undissolved gases (N_2 , CO_2), free water or other separated phases, such as raw or unprocessed gas/liquids mixtures and related materials. The same equipment can be used for these purposes, but additional precautions are generally needed to obtain representative samples of multi-phase products (see **Appendix X1**).

1.3 This practice includes recommendations for the location of a sample point in a line or vessel. It is the responsibility of the user to ensure that the sampling point is located so as to obtain a representative sample.

1.4 The values stated in SI units are to be regarded as standard. The values given in parentheses are for information only.

1.5 *This standard does not purport to address all of the safety concerns, if any, associated with its use. It is the responsibility of the user of this standard to establish appropriate safety and health practices, and determine the applicability of regulatory limitations prior to use.*

2. Referenced Documents

2.1 *ASTM Standards:*²

D1265 Practice for Sampling Liquefied Petroleum (LP) Gases, Manual Method

D1835 Specification for Liquefied Petroleum (LP) Gases

2.2 *GPA Standards:*³

GPA 2174 Obtaining Liquid Hydrocarbon Samples for Analysis by Gas Chromatography

GPA 2140 Liquefied Petroleum Gas Specifications and Test Methods

3. Terminology

3.1 *Definitions:*

3.1.1 *floating piston cylinder (FPC), n*—a high pressure sample container, with a free floating internal piston that effectively divides the container into two separate compartments.

¹ This practice is under the jurisdiction of ASTM Committee **D02** on Petroleum Products—Products, Liquid Fuels, and Lubricants and is the direct responsibility of Subcommittee **D02.H0** on Liquefied Petroleum Gas.

Current edition approved Nov. 1, 2012; May 1, 2014. Published February 2013; May 2014. Originally approved in 1978. Last previous edition approved in 2007 as **D3700** **D3700 – 12**, 07. DOI: 10.1520/D3700-12.10.1520/D3700-14.

² For referenced ASTM standards, visit the ASTM website, www.astm.org, or contact ASTM Customer Service at service@astm.org. For *Annual Book of ASTM Standards* volume information, refer to the standard's Document Summary page on the ASTM website.

³ Available from Gas Processors Association (GPA), 6526 E. 60th St., Tulsa, OK 74145, www.gpaglobal.org

3.1.1.1 *Discussion*—

A floating piston cylinder is used to collect a sample of liquid under pressure without the formation of a gaseous phase which can result in changes in the composition of the liquid sample.

3.1.2 *maximum fill volume (reduced fill volume), n*—the volume of a container occupied by the sample, usually expressed as a percentage of the total capacity.

*A Summary of Changes section appears at the end of this standard

3.1.2.1 Discussion—

Some regulatory agencies use the expressions “maximum fill density” and “reduced fill density.”

4. Summary of Practice

4.1 A liquid petroleum gas (LPG) sample is transferred as a liquid under pressure from a sample point to a floating piston cylinder. The floating piston cylinder (FPC) is designed to collect liquid samples with no vaporization by displacing a piston against a pressurizing fluid (preferably an inert gas). The piston serves as a physical barrier between the sample and the pressurizing fluid, at the sampling pressure. The position of the piston at the end of sampling indicates the percent fill of the sample cylinder.

4.2 It is the responsibility of the user of this practice to locate the sample point at a suitable location and orientation where the product being sampled is a representative, single phase, homogeneous liquid.

5. Significance and Use

5.1 This practice allows the collection of a representative sample of LPG that may contain trace volatile dissolved components such as methane, ethane, and nitrogen. Sampling by Practice **D1265** can result in a small, but predictable, loss of these lighter components. Practice **D1265** is suitable for collecting samples for routine specification testing, as the small loss of light components is not significant under Specification **D1835** specification requirements. Practice **D3700** is recommended whenever highly accurate determination of light components is required. For example, compositions determined on samples collected according to Practice **D3700** may be used to establish the product value of NGL mixtures (see **Appendix X1**).

6. Interferences

6.1 An interference in a sampling procedure is anything which compromises the integrity of the sample.

6.2 Incorrect choice of a sample point location can result in a non-representative sample due to solid or liquid contaminants, two phases, storage tank stratification, and so forth.

6.3 Reactivity of steel surfaces can remove or chemically alter trace reactive components such as H₂S, COS, and mercaptan.

6.4 A lubricant used on the floating piston or other internal wetted parts that is soluble in LPG can contaminate the sample.

6.5 Pre-charge (inert) gas can leak into the sample due to worn or damaged piston seals or poor surface finish (see **8.1**).

6.5.1 Consult the manufacturer’s guidelines for suitable procedures to verify a leak-free cylinder, such as pressure testing each side of the cylinder. It is also possible to analyze the sample for inert gas, or the inert gas for hydrocarbon, to detect leakage in either direction.

6.6 Failure to flush sample lines and *dead volumes* can result in contaminants in samples.

6.7 Sampling from stratified tanks, *dead zones* in flowing systems, or inappropriate time periods in composite sampling systems can result in non-representative samples.

6.8 Any material that can create carryover contamination from one sample to the next has to be removed from the cylinder and the cylinder shall be thoroughly cleaned. In addition to cleaning the interior metal surfaces and cleaning the soft parts (O-rings, for example), consideration should be given to replacing the soft parts if they might have absorbed any contamination. Examples of contaminants include glycol, amine, lubricants, sulfur species, solvents, methanol, etc.

7. Apparatus

7.1 Floating Piston Cylinder (FPC):

7.1.1 *Construction*, typically fabricated from corrosion resistant 316 stainless steel, in accordance with the pressure vessel certification requirements in the jurisdictions in which it is to be used, and through which it will be transported. Protective internal coatings or surface treatments are acceptable provided that they do not adversely affect the free movement of the piston, or effectiveness of the seals (see **Fig. 1**).

7.1.1.1 Users should consult with the manufacturer of these sample cylinders and sample collection systems any time ambient or product temperatures, or both, exceed the range of -29°C (-20°F) to 60°C (140°F). Extreme temperature effects upon metal, O-rings, valve seats, seals, gauges, relief devices, sample pump components and other devices and components in the system should be assessed in a hazards analysis before any sampling takes place.

NOTE 1—At present, there is no international approval process for pressure cylinders. Cylinders require appropriate approval in each jurisdiction in which they are used or transported.

7.1.2 *Volume of Sample*—The minimum volume required is determined by the combined volumes required by each of the tests to be performed, typically 400 mL (that is, 80 % of a 500 mL sample cylinder at 15°C).

7.1.2.1 For safe handling of these cylinders under extremes of product or ambient temperatures, or both, the user shall consider the effects of thermal expansion on the volume of product in the cylinder. For example, if a product is sampled at -40°C

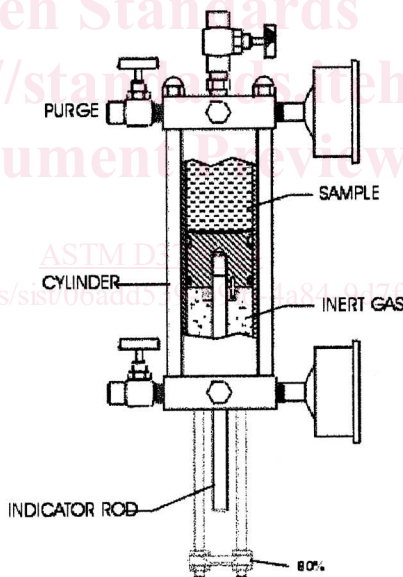
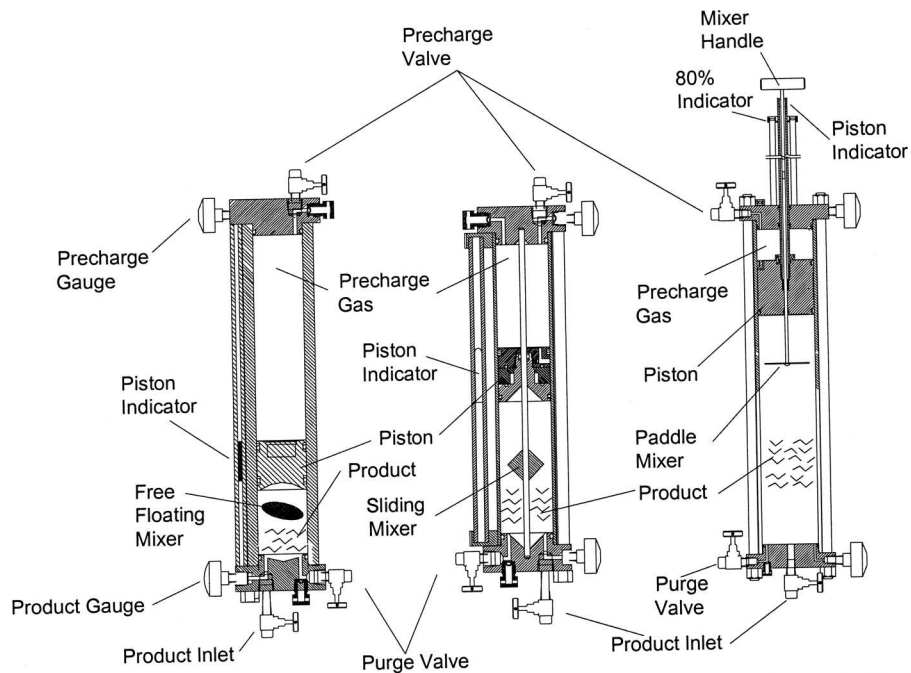

FIG. 1 Typical Floating Piston Cylinder Designs

(-40°F), -40 °C (-40 °F), the user shall plan for the cylinder and sample to warm considerably during transport and before analysis is performed in the laboratory. During summer months, the temperature of the cylinder and product could reasonably be expected to rise to as high as 46°C (115°F) in hot environments. A cylinder initially filled cold to 80 % of its capacity will, upon warming, be over-pressured and the relief device(s) will activate under these conditions. Hydrocarbon releases of this type are unexpected and dangerous. In such an extreme, but not uncommon case, the cylinder should not be filled more than approximately 60 % of its capacity during the initial fill. Users should review ASTM/API/GPA volume correction factor calculations, or data from similar samples, or both, to determine the maximum fill for the product and conditions being sampled, but should always leave at least 10 % vapor space after allowing for the worst likely case of thermal expansion.

NOTE 2—The appropriate tables for conversion of LPG volume or density as a function of temperature are: MNLTP27, Manual on Petroleum Measurement Standards, Chapter 11—Physical Properties Data, Section 2, Part 4—Temperature Correction for the Volume of NGL and LPG Tables 23E, 24E, 53E, 59E, and 60E;² or GPA Technical Publication TP-27.³

7.1.3 *Piston Position Indicator*—The FPC shall be equipped with a piston position indicator such as a magnetic follower, piston rod, or equivalent which indicates the sample volume to comply with the maximum percent fill (maximum fill volume) allowed for storage and transportation. An outage chamber with indicating level device may also be used.

7.1.3.1 Floating piston cylinders that are not equipped with a piston position indicator shall not be used without a procedure to allow the operator to verify fill volume immediately after sampling and prior to transport. Consult the authority having jurisdiction for acceptable procedures.

7.1.4 The cylinder shall include a mechanism to mix the sample in the sample chamber in case of stratified mixtures or water haze that can settle after sampling. This mechanism may be a mechanical mixer/vortex plate on a movable rod, a freely moving rolling ball or slider, magnetically coupled stirrer, or similar mixing device. It is the responsibility of the user to provide sufficient mixing with the mechanism used to allow a representative sample to be withdrawn.

7.2 Lubricants used to lubricate or seal the floating piston, O-ring seals, and other components shall be inert and insoluble in LPG.

~~NOTE 3—DuPont Krytox AC or AD⁴ have been found to be suitable.~~

7.2.1 DuPont Krytox (trademarked) AC or AD^{4,5} have been found to be suitable. DuPont Krytox General Purpose Lubricants GPL 107 (viscous oil) and GPL 201 (light grease)^{4,5} have been found to be suitable in floating piston cylinders, and are less costly than the aerospace grades [AC and AD] of PTFE lubricants. These lubricants are insoluble in aliphatic/aromatic hydrocarbons, water, caustic, amines, and glycols.

7.2.2 Some common grades of silicone based ‘O’ ring lubricants have been successfully used for LPG due to the low solvency of light paraffinic hydrocarbons such as propane and butanes. However, these lubricants are quickly removed by aromatic hydrocarbons and crude oils, and are not recommended for this service.

~~NOTE 3—The use of lubricants that are soluble in hydrocarbon samples will result in contamination of the sample and loss of sealing integrity of the floating piston.~~

7.3 A safety relief device is required to prevent over-pressure in the event that a cylinder becomes fully liquid filled (hydraulically locked) from either overfilling or liquid thermal expansion from excessive temperature increase.

7.3.1 A rupture disk or a self-resetting pressure relief valve shall be fitted to the cylinder to prevent overpressure from hydraulic filling due to temperature increase. A self-resetting pressure relief valve (“popet valve”) is preferred.

~~NOTE 4—DuPont KEL-F⁴ has been found to be suitable. Polytetrafluoroethylene (PTFE) or other materials that are prone to *creep* under pressure, and metal-to-metal valve seals are not recommended.~~

7.3.1.1 DuPont KEL-F^{4,5} has been found to be suitable.

7.3.1.2 Polytetrafluoroethylene (PTFE) or other materials that are prone to *creep* under pressure, and metal-to-metal valve seals are not recommended.

7.3.2 Users may not alter valves or safety relief devices that are required as part of a cylinder permit or exemption.

7.3.2.1 The USA has an exemption system and Canada has a permitting procedure for non-ASME or DOT cylinders.

7.4 *Sampling System*—It is not possible to provide a single procedure that will be applicable for all sampling situations. Different procedures and sampling equipment may be required for sampling pipes, storage tanks, rail cars, trucks, and smaller storage vessels in order to obtain a representative sample (see 4.2).

7.4.1 Sample equipment and procedures shall be designed and used to obtain representative samples of a product, and to maintain sample integrity for the tests being performed. A typical sampling system for LPG flowing in a pipe is shown in Fig. 2.

~~NOTE 4—While not required by this practice, the use of a sample probe in a flowing line is recommended. The sample probe should be located on the top or side of a line, extending into the center third of the flowing stream. Sample points should not be installed on the bottom of a line, unless provisions are made to flush any accumulated debris from the sample point immediately prior to sampling. The sample probe should not be horizontal; rather it should have enough elevation to be sure any heavy contaminants that might be encountered, including water, will tend to drain out of it. The probe should be placed in a horizontal piece of pipe and within 45 degrees of vertical for ordinary sampling.~~

To determine sediment and water in a condensate sample, the probe tip should be placed after a static mixing system to ensure it samples the mixed stream and collects a representative sample of the full stream. In general, it is recommended that these sample systems are in a vertical run of pipe following a static mixer, with downward flow through the mixer and then the sample point. In this case, with a vertical piping run, a horizontal probe is recommended.

~~NOTE 5—Reactive materials should be tested as soon as possible after they are collected. When accurate determinations are absolutely critical, consideration should be given to use of portable or online analytical equipment to test the product directly at the source, rather than potentially compromising the integrity of the sample during transportation and handling.~~

7.4.2 Transfer lines, valves, pressure gages and so forth in the transfer system shall be corrosion resistant (typically stainless steel) and designed consistent with maximum anticipated pressure. Experience has shown that the transfer lines should have a minimum internal diameter of 3 mm nominal (1/8 in.) and be as short as practical to minimize line blockage or sample vaporization, or both. The use of filters, dryers, needle valves and so forth are not recommended, unless provisions are made to prevent excessive flow restriction and pressure drop. A “T” junction with a purge valve at the sample connection point is recommended to allow purging of the dead volume at the sampler connection. Flexible hose or tubing with adequate pressure rating may be used.

⁴ Registered trademarks of E. I. du Pont de Nemours and Company, Wilmington, DE.

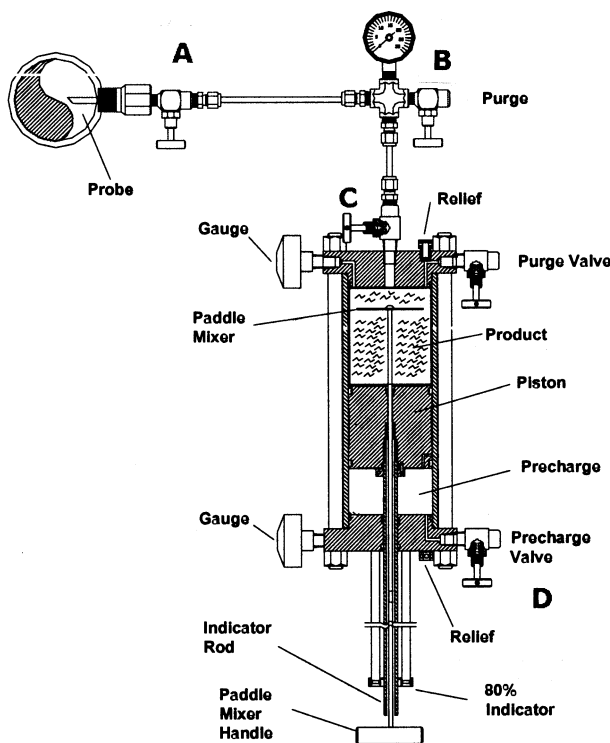

FIG. 2 Typical Sampling System with Valving

NOTE 6—While not required by this practice, the use of non-reactive and non-absorptive materials is recommended, especially when sampling to determine trace levels of reactive or polar materials such as H₂S and water.

7.4.3 Other piping arrangements may be acceptable, but may require different flushing procedures prior to sample collection. Typical sample loops are shown in Figs. 3 and 4.

7.4.4 Closed-loop Sample loops that are closed side stream samplers designed to minimize volatile light end losses during sampling may be used. The sample loop system shall be connected to on-line analyzers or composite samplers in a manner that ensures sample integrity is maintained for the tests being performed.

7.4.5 Sample loops should preferably be installed around pumps, valves, or other sources of pressure drop to minimize atmospheric emissions from purging of sample lines. Do not install sampling loops around a meter, as bypassing the meter can create a bias in measurement and error in indicated volume.

7.4.5.1 Do not install sample loops around a meter, as bypassing the meter can create a bias in measurement and error in indicated volume.

7.4.6 Sampling pumps or other means of controlling pressures higher than the vapor pressure of the sample may be acceptable, and may be used to flush the lines or the cylinder dead volume, or both, if any, prior to sample collection. The cylinder may be partially filled and then emptied prior to collection of the sample as an alternative to venting hydrocarbon to flush lines.

7.5 Composite Sampler:

7.5.1 A composite sampler (also called a proportional sampler) is a device that is used to obtain a representative sample from a flowing product stream by accumulating small portions of product over a period of time. The sampling system consists of a sample probe, a means of collecting repetitive small portions, and a floating piston cylinder to accumulate the total sample. Figs. 5 and 6 show typical sample systems using a probe-mounted sample pump (Fig. 5), or a flow-through sample injection valve (Fig. 6).

7.5.2 Thorough purging of sample lines, pumps, and connections to the sample cylinder is necessary to avoid contamination of the sample. A suitable purging arrangement at the point of sampling shall be provided. This purging arrangement may take the form of a “T” connection and purging valve, or an operating procedure that allows slight loosening of the connection to vent the dead volume at the sample connection (if allowed by the local jurisdiction). Composite sampler systems shall be designed to minimize dead end lines that could result in the sample not being representative of the LPG source.

⁵ The sole source of supply of the apparatus known to the committee at this time is E. I. du Pont de Nemours and Company, <http://www.dupont.com>. If you are aware of alternative suppliers, please provide this information to ASTM International Headquarters. Your comments will receive careful consideration at a meeting of the responsible technical committee,¹ which you may attend.

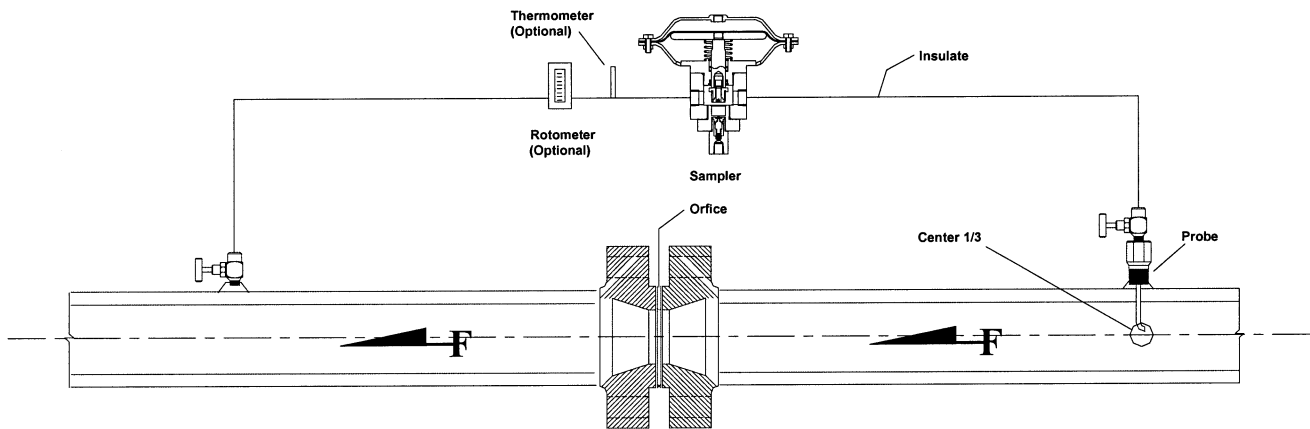

FIG. 3 Typical Sample Probe Installation on Orifice Fitting

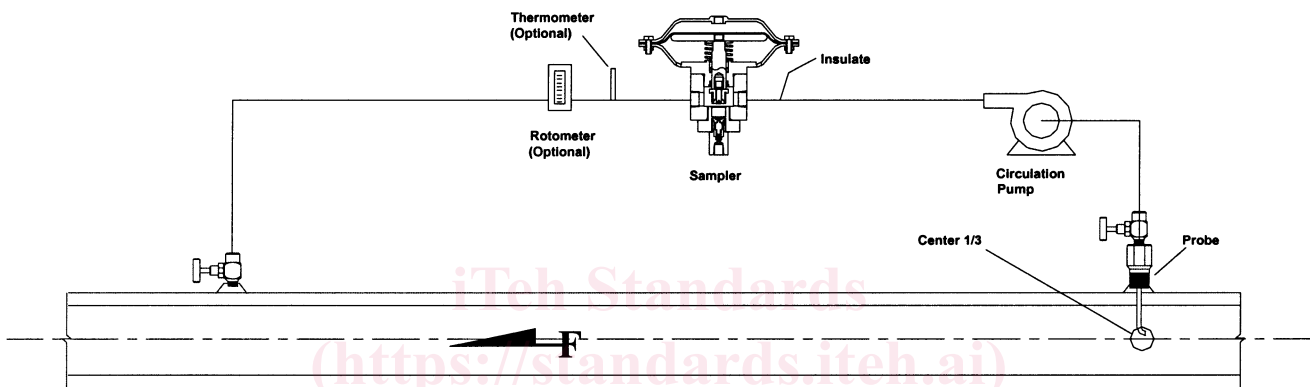

FIG. 4 Typical Sample Probe Installation for a Pump-Assisted Sample Loop System

7.5.3 Take precautions to avoid vaporization in sample loop lines when operating near the equilibrium vapor pressure of the LPG. To control the pressure or temperature of sample containers, it may be necessary either to cool or insulate the sample line and sample container, or both.

7.5.4 Ensure that the pressure at the sample point is above the vapor pressure of the sample to avoid vaporization in the pipe or sampling lines when using a device such as an orifice plate or valve to create a pressure differential for sampling.

7.5.5 The floating piston cylinder shall be connected to the purged sample line of the composite sampler. Apply inert gas pressure (pre-charge gas) to the cylinder to force the piston to the sample point end of the FPC. Maintain the inert gas pressure at a pressure that exceeds the equilibrium vapor pressure of the fluid sampled under the expected temperature conditions by about 350 to 1400 kPa (50 to 200 psi). At pressure differences less than about 350 kPa (50 psi), there is an increasing chance of non-representative samples. Transient pressure fluctuation below the vapor pressure can result in non-representative samples.

7.5.6 Adjust the automatic sample injection valve to obtain incremental samples at a rate such that the floating piston cylinder will have adequate capacity to hold the combined sample aliquots during its period of sampling. Set the sampling rate to prevent overfilling of the sample container, considering the sample size, maximum anticipated flow rates and time periods. Incorrect operation can result in a liquid filled cylinder that does not have a representative sample, since sampling might have stopped prior to the end of the sampling period, or preferential release of light ends occurred (depending upon venting configuration).

7.5.7 Adjust the total volume taken over the sampling period in proportion to the flow rate of the product by adjusting each incremental sample volume taken by the sampling valve, or adjusting the frequency of incremental samples, or both.

7.5.8 The floating piston cylinder used in the above system may be removed from the composite sampling device after the desired sample has been collected.

7.5.9 Do not take outage or reduce pressure on the cylinder. Check valves for leaks, cap valves with the correct fittings, and use pipe tape on pipe threads to protect threads. Prepare the sample information tag and box for transport according to the Department of Transportation or other applicable requirements of the authority having jurisdiction.

7.5.10 If it is not possible to disconnect the primary floating piston cylinder from the automatic system, mix the sample in the primary cylinder to homogenize it and transfer sample to a secondary floating piston cylinder. Proceed as in 9.2.1, treating the primary cylinder as a flowing source. In this particular transfer situation, as sample is withdrawn, the master sample container will partially depressurize. Maintain the pre-charge (inert gas) pressure above the product vapor pressure at the existing master sampler temperature to prevent flashing. **(Warning—**The cylinder shall not be filled beyond 80 % of its capacity with sample. In the event