



# Standard Test Methods for DC Resistance or Conductance of Insulating Materials<sup>1</sup>

This standard is issued under the fixed designation D257; the number immediately following the designation indicates the year of original adoption or, in the case of revision, the year of last revision. A number in parentheses indicates the year of last reapproval. A superscript epsilon ( $\epsilon$ ) indicates an editorial change since the last revision or reapproval.

*This standard has been approved for use by agencies of the U.S. Department of Defense.*

## 1. Scope\*

1.1 These test methods cover direct-current procedures for the measurement of dc insulation resistance, volume resistance, and surface resistance. From such measurements and the geometric dimensions of specimen and electrodes, both volume and surface resistivity of electrical insulating materials can be calculated, as well as the corresponding conductances and conductivities.

1.2 These test methods are not suitable for use in measuring the electrical resistance/conductance of moderately conductive materials. Use Test Method **D4496** to evaluate such materials.

1.3 This standard describes several general alternative methodologies for measuring resistance (or conductance). Specific materials can be tested most appropriately by using standard ASTM test methods applicable to the specific material that define both voltage stress limits and finite electrification times as well as specimen configuration and electrode geometry. These individual specific test methodologies would be better able to define the precision and bias for the determination.

1.4 The procedures appear in the following sections:

Test Method or Procedure	Section
Calculation	—13
Choice of Apparatus and Test Method	—7
Cleaning Solid Specimens	—10.1
Conditioning of Specimens	—11
Effective Area of Guarded Electrode	—Appendix X2
Electrode Systems	—6
Factors Affecting Insulation Resistance or Conductance	—Appendix X1
—Measurements	—11.2
Humidity Control	—9.4
Liquid Specimens and Cells	—15
Precision and Bias	—12
Procedure for the Measurement of Resistance or Conductance	—2
Referenced Documents	—14
Report	—8
Sampling	—5
Significance and Use	—10
Specimen Mounting	—4
Summary of Test Methods	—3
Terminology	—9
Test Specimens for Insulation, Volume, and Surface Resistance or Conductance Determination	—Appendix X3
Typical Measurement Methods	

1.4 This standard does not purport to address all of the safety concerns, if any, associated with its use. It is the responsibility of the user of this standard to establish appropriate safety and health practices and determine the applicability of regulatory limitations prior to use.

<sup>1</sup> These test methods are under the jurisdiction of ASTM Committee **D09** on Electrical and Electronic Insulating Materials and are the direct responsibility of Subcommittee **D09.12** on Electrical Tests.

Current edition approved ~~May 15, 2007~~ April 1, 2014. Published ~~June 2007~~ May 2014. Originally approved in 1925. Last previous edition approved in 2005 as **D257–99**/**D257–07** (2005). DOI: 10.1520/D0257-07.10.1520/D0257-14.

\*A Summary of Changes section appears at the end of this standard

## 2. Referenced Documents

### 2.1 ASTM Standards:<sup>2</sup>

D150 Test Methods for AC Loss Characteristics and Permittivity (Dielectric Constant) of Solid Electrical Insulation

D374 Test Methods for Thickness of Solid Electrical Insulation (Withdrawn 2013)<sup>3</sup>

D1169 Test Method for Specific Resistance (Resistivity) of Electrical Insulating Liquids

D1711 Terminology Relating to Electrical Insulation

D4496 Test Method for D-C Resistance or Conductance of Moderately Conductive Materials

D5032 Practice for Maintaining Constant Relative Humidity by Means of Aqueous Glycerin Solutions

D6054 Practice for Conditioning Electrical Insulating Materials for Testing (Withdrawn 2012)<sup>3</sup>

E104 Practice for Maintaining Constant Relative Humidity by Means of Aqueous Solutions

## 3. Terminology

### 3.1 Definitions:

3.1.1 The following definitions are taken from Terminology D1711 and apply to the terms used in the text of this standard.

3.1.2 *conductance, insulation, n*—the ratio of the total volume and surface current between two electrodes (on or in a specimen) to the dc voltage applied to the two electrodes.

---

<sup>2</sup> For referenced ASTM standards, visit the ASTM website, [www.astm.org](http://www.astm.org), or contact ASTM Customer Service at [service@astm.org](mailto:service@astm.org). For *Annual Book of ASTM Standards* volume information, refer to the standard's Document Summary page on the ASTM website.

<sup>3</sup> The last approved version of this historical standard is referenced on [www.astm.org](http://www.astm.org).

#### 3.1.2.1 Discussion—

Insulation conductance is the reciprocal of insulation resistance.

3.1.3 *conductance, surface, n*—the ratio of the current between two electrodes (on the surface of a specimen) to the dc voltage applied to the electrodes.

#### 3.1.3.1 Discussion—

(Some volume conductance is unavoidably included in the actual measurement.) Surface conductance is the reciprocal of surface resistance.

3.1.4 *conductance, volume, n*—the ratio of the current in the volume of a specimen between two electrodes (on or in the specimen) to the dc voltage applied to the two electrodes.

#### 3.1.4.1 Discussion—

Volume conductance is the reciprocal of volume resistance.

3.1.5 *conductivity, surface, n*—the surface conductance multiplied by that ratio of specimen surface dimensions (distance between electrodes divided by the width of electrodes defining the current path) which transforms the measured conductance to that obtained if the electrodes had formed the opposite sides of a square.

#### 3.1.5.1 Discussion—

Surface conductivity is expressed in siemens. It is popularly expressed as siemens/square (the size of the square is immaterial). Surface conductivity is the reciprocal of surface resistivity.

3.1.6 *conductivity, volume, n*—the volume conductance multiplied by that ratio of specimen volume dimensions (distance between electrodes divided by the cross-sectional area of the electrodes) which transforms the measured conductance to that conductance obtained if the electrodes had formed the opposite sides of a unit cube.

#### 3.1.6.1 Discussion—

Volume conductivity is usually expressed in siemens/centimetre or in siemens/metre and is the reciprocal of volume resistivity.

3.1.7 *moderately conductive, adj*—describes a solid material having a volume resistivity between 1 and 10 000 000  $\Omega$ -cm.

3.1.8 *resistance, insulation, (R<sub>i</sub>), n*—the ratio of the dc voltage applied to two electrodes (on or in a specimen) to the total volume and surface current between them.

### 3.1.8.1 Discussion—

Insulation resistance is the reciprocal of insulation conductance.

3.1.9 *resistance, surface, ( $R_s$ ),  $n$* —the ratio of the dc voltage applied to two electrodes (on the surface of a specimen) to the current between them.

### 3.1.9.1 Discussion—

(Some volume resistance is unavoidably included in the actual measurement.) Surface resistance is the reciprocal of surface conductance.

3.1.10 *resistance, volume, ( $R_v$ ),  $n$* —the ratio of the dc voltage applied to two electrodes (on or in a specimen) to the current in the volume of the specimen between the electrodes.

### 3.1.10.1 Discussion—

Volume resistance is the reciprocal of volume conductance.

3.1.11 *resistivity, surface, ( $\rho_s$ ),  $n$* —the surface resistance multiplied by that ratio of specimen surface dimensions (width of electrodes defining the current path divided by the distance between electrodes) which transforms the measured resistance to that obtained if the electrodes had formed the opposite sides of a square.

### 3.1.11.1 Discussion—

Surface resistivity is expressed in ohms. It is popularly expressed also as ohms/square (the size of the square is immaterial). Surface resistivity is the reciprocal of surface conductivity.

3.1.12 *resistivity, volume, ( $\rho_v$ ),  $n$* —the volume resistance multiplied by that ratio of specimen volume dimensions (cross-sectional area of the specimen between the electrodes divided by the distance between electrodes) which transforms the measured resistance to that resistance obtained if the electrodes had formed the opposite sides of a unit cube.

### 3.1.12.1 Discussion—

Volume resistivity is usually expressed in ohm-centimetres (preferred) or in ohm-metres. Volume resistivity is the reciprocal of volume conductivity.

## 4. Summary of Test Methods

4.1 The resistance or conductance of a material specimen or of a capacitor is determined from a measurement of current or of voltage drop under specified conditions. By using the appropriate electrode systems, surface and volume resistance or conductance ~~may be~~ are measured separately. The resistivity or conductivity ~~can then be calculated when the required~~ is calculated with the known specimen and electrode dimensions are known.

## 5. Significance and Use

5.1 Insulating materials are used to isolate components of an electrical system from each other and from ground, as well as to provide mechanical support for the components. For this purpose, it is generally desirable to have the insulation resistance as high as possible, consistent with acceptable mechanical, chemical, and heat-resisting properties. Since insulation resistance or conductance combines both volume and surface resistance or conductance, its measured value is most useful when the test specimen and electrodes have the same form as is required in actual use. Surface resistance or conductance changes rapidly with humidity, while volume resistance or conductance changes slowly ~~although~~ with the ~~final change may eventually be greater~~ total change being greater in some cases.

5.2 Resistivity or conductivity ~~may be~~ is used to predict, indirectly, the low-frequency dielectric breakdown and dissipation factor properties of some materials. Resistivity or conductivity is often used as an indirect measure of: moisture content, degree of cure, mechanical continuity, or deterioration of various types. The usefulness of these indirect measurements is dependent on the degree of correlation established by supporting theoretical or experimental investigations. A decrease of surface resistance ~~may result~~ results either in an increase of the dielectric breakdown voltage because the electric field intensity is reduced, or a decrease of the dielectric breakdown voltage because the area under stress is increased.

5.3 All the dielectric resistances or conductances depend on the length of time of electrification and on the value of applied voltage (in addition to the usual environmental variables). These must be known and reported to make the measured value of

resistance or conductance meaningful. Within the electrical insulation materials industry, the adjective “apparent” is generally applied to resistivity values obtained under conditions of arbitrarily selected electrification time. See X1.4.

5.4 Volume resistivity or conductivity can be calculated from resistance and dimensional data for use as an aid in designing an insulator for a specific application. ~~The change~~ Studies have shown changes of resistivity or conductivity with temperature and humidity may be great (1, 2, 3, 4),<sup>4</sup> and ~~These changes~~ must be known when designing for operating conditions. Volume resistivity or conductivity determinations are often used in checking the uniformity of an insulating material, either with regard to processing or to detect conductive impurities that affect the quality of the material and that ~~may~~ are not be readily detectable by other methods.

5.5 Volume resistivities above  $10^{21} \Omega\cdot\text{cm}$  ( $10^{19} \Omega\cdot\text{m}$ ), calculated from data obtained on specimens tested under usual laboratory conditions, are of doubtful validity, considering the limitations of commonly used measuring equipment.

5.6 Surface resistance or conductance cannot be measured accurately, only approximated, because some degree of volume resistance or conductance is always involved in the measurement. The measured value is also affected by the surface contamination. Surface contamination, and its rate of accumulation, is affected by many factors including electrostatic charging and interfacial tension. These, in turn, ~~may~~ affect the surface resistivity. Surface resistivity or conductivity can be considered to be related to material properties when contamination is involved but is not a material property of electrical insulation material in the usual sense.

6. Electrode Systems

6.1 The electrodes for insulating materials should be of a material that is readily applied, allows are to allow intimate contact with the specimen surface, ~~and introduces no appreciable~~ without introducing significant error because of electrode resistance or contamination of the specimen (5). The electrode material should is to be corrosion-resistant under the conditions of the test. For tests of fabricated specimens such as feed-through bushings, cables, etc., the electrodes employed are a part of the specimen or its mounting. ~~Measurements~~ In such cases, ~~measurements~~ of insulation resistance or ~~conductance~~, then, ~~conductance~~ include the contaminating effects of electrode or mounting materials and are generally related to the performance of the specimen in actual use.

6.1.1 Binding-Post and Taper-Pin Electrodes, Fig. 1 and Fig. 2, provide a means of applying voltage to rigid insulating materials to permit an evaluation of their resistive or conductive properties. These electrodes ~~simulate~~ attempt to ~~some degree~~ simulate the actual conditions of use, such as binding posts on instrument panels and terminal strips. In the case of laminated insulating materials having high-resin-content surfaces, ~~some~~ what lower insulation resistance values may be are obtained with taper-pin than with binding posts, due to more intimate contact with the body of the insulating material. Resistance or conductance values obtained are highly influenced by the individual contact between each pin and the dielectric material, the surface roughness of the pins, and the smoothness of the hole in the dielectric material. Reproducibility of results on different specimens is difficult to obtain.

6.1.2 Metal Bars in the arrangement of Fig. 3 were primarily devised to evaluate the insulation resistance or conductance of flexible tapes and thin, solid specimens as a fairly simple and convenient means of electrical quality control. This arrangement is ~~some~~ what more satisfactory for obtaining approximate values of surface resistance or conductance when the width of the insulating material is much greater than its thickness.

<sup>4</sup> The boldface numbers in parentheses refer to the list of references appended to these test methods.

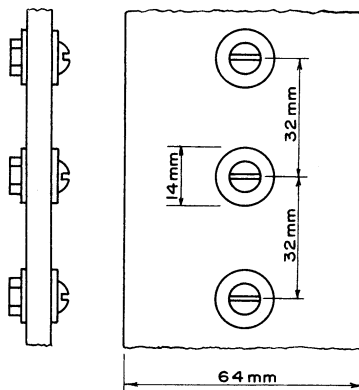
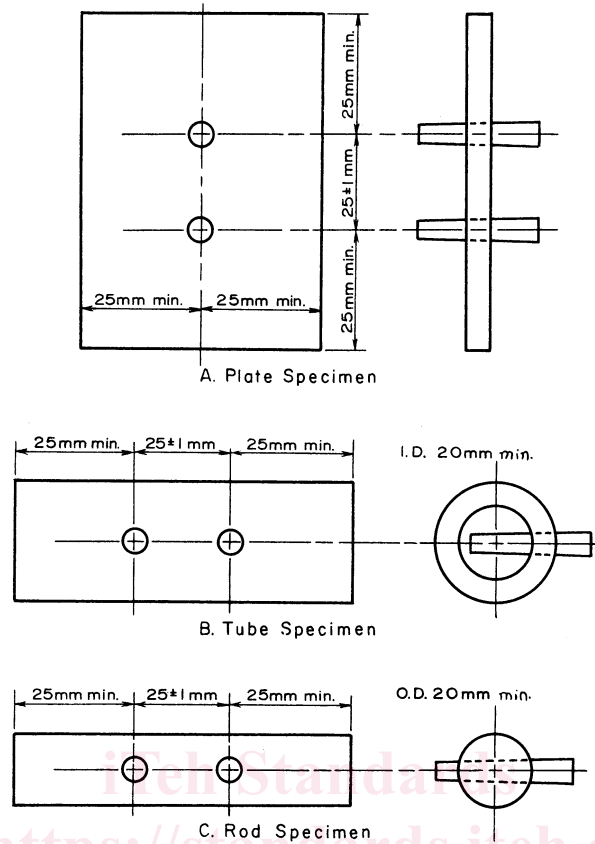

FIG. 1 Binding-Post Electrodes for Flat, Solid Specimens



Use Pratt & Whitney No.3 Taper Pins

FIG. 2 Taper-Pin Electrodes

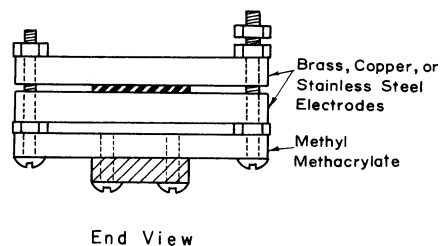
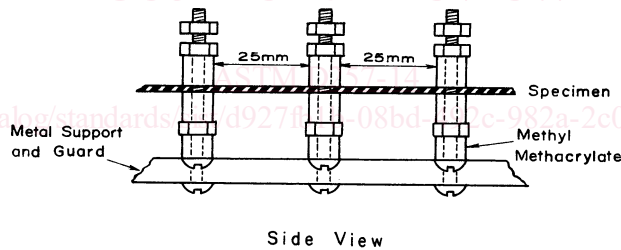

FIG. 3 Strip Electrodes for Tapes and Flat, Solid Specimens

6.1.3 *Silver Paint*, Fig. 4, Fig. 5, and Fig. 6, is available commercially with a high conductivity, either air-drying or low-temperature-baking varieties, which are sufficiently porous to permit diffusion of moisture through them and thereby allow the test specimen to be conditioned after the application of the electrodes. This is a particularly useful feature in studying resistance-humidity effects, as well as change with temperature. However, before conductive paint is used as an electrode material, it should shall be established that the solvent in the paint does not attack the material so as to change changing its electrical properties. Reasonably smooth Smooth edges of guard electrodes may be obtained with are obtained by using a fine-bristle brush.

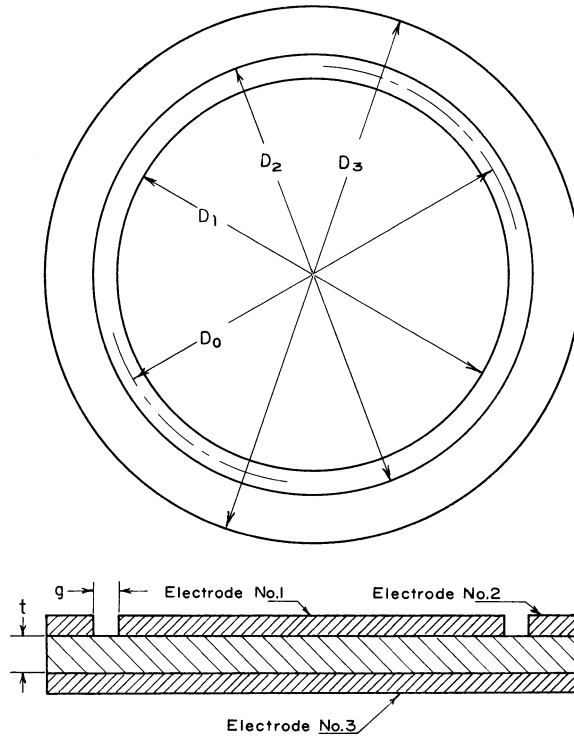

FIG. 4 Flat Specimen for Measuring Volume and Surface Resistances or Conductances

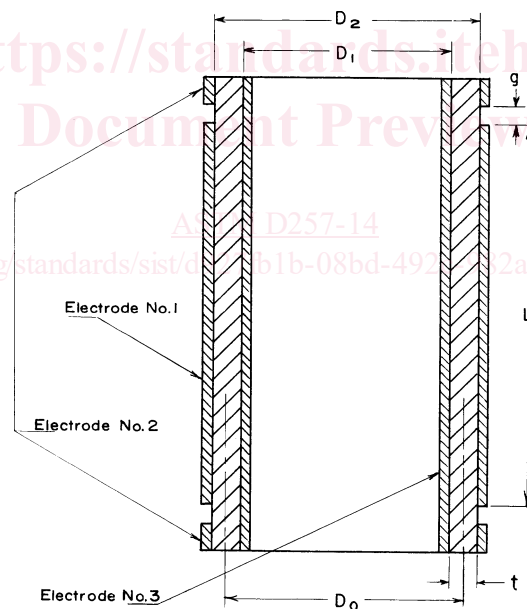
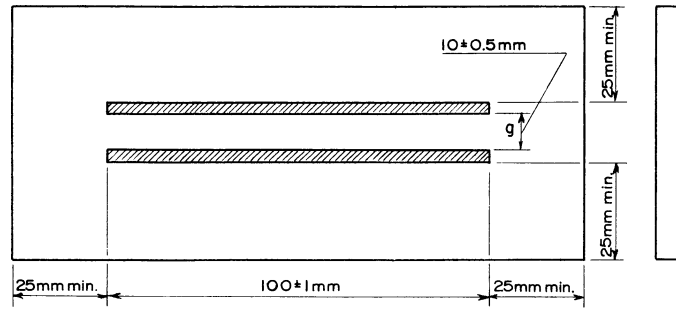

FIG. 5 Tubular Specimen for Measuring Volume and Surface Resistances or Conductances

However, for circular electrodes, sharper edges can be are obtained by the use of a ruling compass and silver paint for drawing the outline circles of the electrodes and filling in the enclosed areas by brush. A narrow strip of masking tape may be used, provided the pressure-sensitive adhesive used does not contaminate the surface of the specimen. Clamp-on masks also may be used if the electrode paint is sprayed on.

6.1.4 *Sprayed Metal*, Fig. 4, Fig. 5, and Fig. 6, may be are used if satisfactory adhesion to the test specimen can be obtained. Thin-it is possible that thin sprayed electrodes may will have certain advantages in that they are ready for use as soon as applied. They may be sufficiently porous to allow the specimen to be conditioned, but this should be verified. Narrow strips of masking tape or clamp-on masks must be used to produce a gap between the guarded and the guard electrodes. Use a tape that is known not to contaminate the gap surface.

6.1.5 *Evaporated Metal* may be are used under the same conditions given in 6.1.4.



A - Plate Specimen

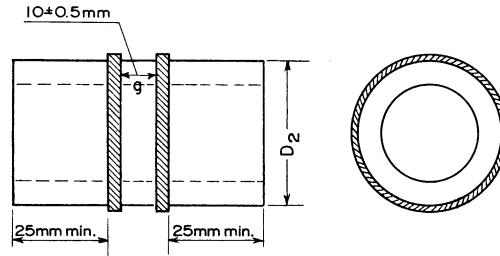

B - Tube or Rod Specimen

FIG. 6 Conducting-Paint Electrodes

6.1.6 *Metal Foil*, Fig. 4, may be applied to specimen surfaces as electrodes. The usual thickness of metal foil used for resistance or conductance studies of dielectrics ranges from 6 to 80  $\mu\text{m}$ . Lead or tin foil is in most common use, and is usually attached to the test specimen by a minimum quantity of petrolatum, silicone grease, oil, or other suitable material, as an adhesive. Such electrodes shall be applied under a smoothing pressure sufficient to eliminate all wrinkles, and to work excess adhesive toward the edge of the foil where it can be wiped off with a cleansing tissue. One very effective method is to use a hard narrow roller (10 to 15 mm wide), and to roll outward on the surface until no visible imprint can be made on the foil with the roller. This technique can be used satisfactorily only on specimens that have very flat surfaces. With care, the adhesive film can be reduced to 2.5  $\mu\text{m}$ . As this film is in series with the specimen, it will always cause the measured resistance to be too high. This error may be it is possible that this error will become excessive for the lower-resistivity specimens of thickness less than 250  $\mu\text{m}$ . Also the hard roller can force sharp particles into or through thin films (50  $\mu\text{m}$ ). Foil electrodes are not porous and will not allow the test specimen to condition after the electrodes have been applied. The adhesive may lose its effectiveness at elevated temperatures necessitating the use of flat metal back-up plates under pressure. It is possible, with the aid of a suitable cutting device, to cut a proper width strip from one electrode to form a guarded and guard electrode. Such a three-terminal specimen normally cannot be used for surface resistance or conductance measurements because of the grease remaining on the gap surface. It may be very difficult to clean the entire gap surface without disturbing the adjacent edges of the electrode.

6.1.7 *Colloidal Graphite*, Fig. 4, dispersed in water or other suitable vehicle, may be brushed on nonporous, sheet insulating materials to form an air-drying electrode. Masking tapes or clamp-on masks may be used (6.1.4). This electrode material is recommended only if all of the following conditions are met:

6.1.7.1 The material to be tested must accept a graphite coating that will not flake before testing,

6.1.7.2 The material being tested must not absorb water readily, and

6.1.7.3 Conditioning must be in a dry atmosphere (Procedure B, Practice D6054), and measurements made in this same atmosphere.

6.1.8 Liquid metal electrodes give satisfactory results and may prove to be the best are an alternate method to achieving the contact to the specimen necessary for effective resistance measurements. The liquid metal forming the upper electrodes should shall be confined by stainless steel rings, each of which should shall have its lower rim reduced to a sharp edge by beveling on the side away from the liquid metal. Fig. 7 and Fig. 8 show two possible electrode arrangements.

6.1.9 *Flat Metal Plates*, Fig. 4, (preferably guarded) may be (guarded) are used for testing flexible and compressible materials, both at room temperature and at elevated temperatures. They may be circular or rectangular (for tapes). To ensure intimate contact with the specimen, considerable pressure is usually required. Pressures of 140 to 700 kPa have been found satisfactory (see material specifications). For tapes, the flat metal plates shall be circular or rectangular.

6.1.9.1 A variation of flat metal plate electrode systems is found in certain cell designs used to measure greases or filling compounds. Such cells are preassembled and the material to be tested is either added to the cell between fixed electrodes or the electrodes are forced into the material to a predetermined electrode spacing. Because the configuration of the electrodes in these

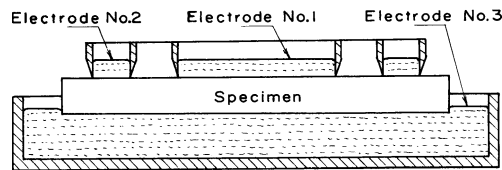
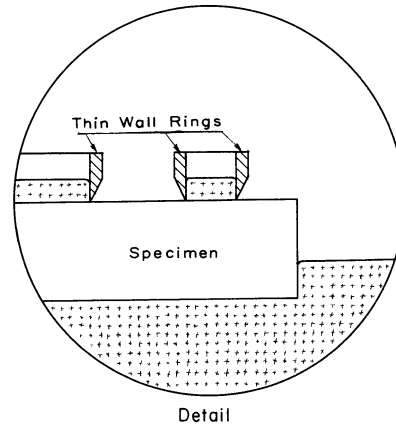

FIG. 7 Liquid Metal Electrodes for Flat, Solid Specimens

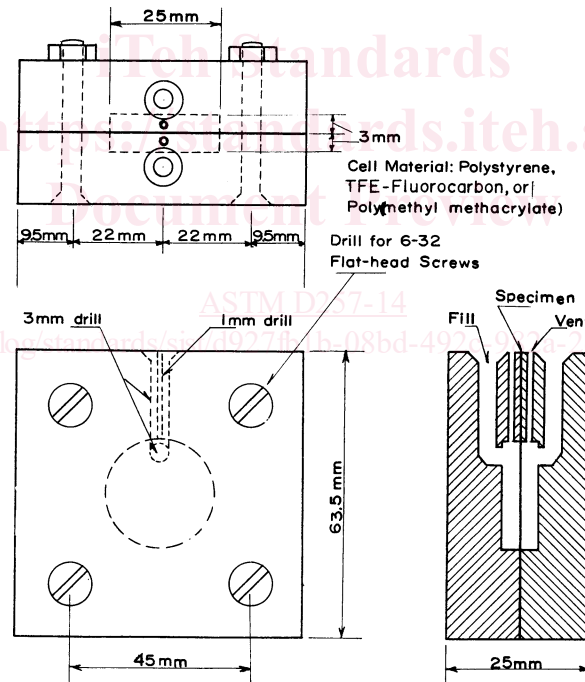

FIG. 8 Liquid Metal Cell for Thin Sheet Material

cells is such that the effective electrode area and the distance between them is difficult to measure, each cell constant,  $K$ , (equivalent to the  $A/t$  factor from Table 1) can be derived from the following equation:

$$K = 3.6 \pi C = 11.3 C \quad (1)$$

where:

$K$  = has units of centimetres, and

$C$  = has units of picofarads and is the capacitance of the electrode system with air as the dielectric. See Test Methods D150 for methods of measurement for  $C$

6.1.10 *Conducting Rubber* has been used as electrode material, as in Fig. 4, and has the advantage that it can quickly and easily be applied and removed from the specimen. As the electrodes are applied only during the time of measurement, they do not



**TABLE 1 Calculation of Resistivity or Conductivity<sup>A</sup>**

Type of Electrodes or Specimen	Volume Resistivity, $\Omega\text{-cm}$	Volume Conductivity, S/cm	Effective Area of Measuring Electrode
	$\rho_v = \frac{A}{t} R_v$	$\gamma_v = \frac{t}{A} G_v$	
Circular (Fig. 4)	$\rho_v = \frac{A}{t} R_v$	$\gamma_v = \frac{t}{A} G_v$	$A = \frac{\pi(D_1 + g)^2}{4}$
Rectangular	$\rho_v = \frac{A}{t} R_v$	$\gamma_v = \frac{t}{A} G_v$	$A = (a + g)(b + g)$
Square	$\rho_v = \frac{A}{t} R_v$	$\gamma_v = \frac{t}{A} G_v$	$A = (a + g)^2$
Tubes (Fig. 5)	$\rho_v = \frac{A}{t} R_v$	$\gamma_v = \frac{t}{A} G_v$	$A = \pi D_o(L + g)$
Cables	$\rho_v = \frac{2\pi L R_v}{\ln \frac{D_2}{D_1}}$	$\gamma_v = \frac{\ln \frac{D_2}{D_1}}{2\pi L R_v}$	
	Surface Resistivity, $\Omega$ (per square)	Surface Conductivity, S (per square)	Effective Perimeter of Guarded Electrode
	$\rho_s = \frac{P}{g} R_s$	$\gamma_s = \frac{g}{P} G_s$	
Circular (Fig. 4)	$\rho_s = \frac{P}{g} R_s$	$\gamma_s = \frac{g}{P} G_s$	$P = \pi D_o$
Rectangular	$\rho_s = \frac{P}{g} R_s$	$\gamma_s = \frac{g}{P} G_s$	$P = 2(a + b + 2g)$
Square	$\rho_s = \frac{P}{g} R_s$	$\gamma_s = \frac{g}{P} G_s$	$P = 4(a + g)$
Tubes (Figs. 5 and 6)	$\rho_s = \frac{P}{g} R_s$	$\gamma_s = \frac{g}{P} G_s$	$P = 2\pi D_2$

**Nomenclature:**

$A$  = the effective area of the measuring electrode for the particular arrangement employed,  
 $P$  = the effective perimeter of the guarded electrode for the particular arrangement employed,  
 $R_v$  = measured volume resistance in ohms,  
 $G_v$  = measured volume conductance in siemens,  
 $R_s$  = measured surface resistance in ohms,  
 $G_s$  = measured surface conductance in siemens,  
 $t$  = average thickness of the specimen,  
 $D_o, D_1, D_2, g, L$  = dimensions indicated in Fig. 4 and Fig. 6 (see Appendix X2 for correction to  $g$ ),  
 $a, b,$  = lengths of the sides of rectangular electrodes, and  
 $\ln$  = natural logarithm.

<sup>A</sup>All dimensions are in centimetres.

~~interfere with the conditioning of the specimen.~~ The conductive-rubber material must be backed by proper plates and be soft enough so that effective contact with the specimen is obtained when a reasonable pressure is applied.

NOTE 1—There is evidence that values of conductivity obtained using conductive-rubber electrodes are always smaller (20 to 70 %) than values obtained with tinfoil electrodes (6). When only order-of-magnitude accuracies are required, and these contact errors can be neglected, a properly designed set of conductive-rubber electrodes can provide a rapid means for making conductivity and resistivity determinations.

6.1.11 ~~Water is widely~~ employed as one electrode in testing insulation on wires and cables. Both ends of the specimen must be out of the water and of such length that leakage along the insulation is negligible. Refer to specific wire and cable test methods for the necessity to use guard at each end of a specimen. For standardization it is desirable to add sodium chloride to the water ~~so as to produce a sodium chloride concentration of 1.0 to 1.1 % NaCl to ensure adequate conductivity. Measurements at temperatures up to about 100 °C have been reported as feasible.~~ reported.

## 7. Choice of Apparatus and Test Method

7.1 ~~Power Supply~~—A source of ~~very~~ steady direct voltage is required (see X1.7.3). Batteries or other stable direct voltage supplies have been proven suitable for use.

7.2 ~~Guard Circuit~~—Whether measuring resistance of an insulating material with two electrodes (no guard) or with a three-terminal system (two electrodes plus guard), consider how the electrical connections are made between the test instrument and the test specimen. If the test specimen is at some distance from the test instrument, or the test specimen is tested under humid

conditions, or if a relatively high ( $10^{10}$  to  $10^{15}$  ohms) specimen resistance is expected, spurious resistance paths can easily exist between the test instrument and test specimen. A guard circuit is necessary must be used to minimize interference from these spurious paths (see also X1.9).

7.2.1 *With Guard Electrode*—Use coaxial cable, with the core lead to the guarded electrode and the shield to the guard electrode, to make adequate guarded connections between the test equipment and test specimen. Coaxial cable (again with the shield tied back to the guard) for the unguarded lead is not mandatory here (or in specimen 7.2.2), although its use provides some reduction in background noise (see also (see Fig. 9).

7.2.2 *Without Guard Electrode*—Use coaxial cable, with the core lead to one electrode and the shield terminated about 1 cm from the end of the core lead (see also Fig. 10).

7.3 *Direct Measurements*—The current through a specimen at a fixed voltage is measured using any equipment that has the required  $\pm 10\%$  sensitivity and accuracy ( $\pm 10\%$  is usually adequate). accuracy. Current-measuring devices available include electrometers, d-c amplifiers with indicating meters, and galvanometers. Typical methods and circuits are given in Appendix X3. When the measuring device scale is calibrated to read ohms directly no calculations are required for resistance measurements.

7.4 *Comparison Methods*—A Wheatstone-bridge circuit may be is used to compare the resistance of the specimen with that of a standard resistor (see Appendix X3).

7.5 *Precision and Bias Considerations:*

7.5.1 *General*—As a guide in the choice of apparatus, the pertinent considerations are summarized in Table 2, but it is not implied that the examples enumerated are the only ones applicable. This table is not intended to indicate the limits of sensitivity and error of the various methods limits per se, but rather is intended to indicate limits that are distinctly possible with modern apparatus. In any case, such limits can be achieved or exceeded only through careful selection and combination of the apparatus employed. It must be emphasized, however, that the errors considered are those of instrumentation only. Errors such as those discussed in Appendix X1 are an entirely different matter. In this latter connection, the last column of Table 2 lists the resistance that is shunted by the insulation resistance between the guarded electrode and the guard system for the various methods. In general, the lower such resistance, the less probability of error from undue shunting.

NOTE 2—No matter what measurement method is employed, the highest precisions are achieved only with careful evaluation of all sources of error. It is possible either to set up any of these methods from the component parts, or to acquire a completely integrated apparatus. In general, the methods using high-sensitivity galvanometers require a more permanent installation than those using indicating meters or recorders. The methods using indicating devices such as voltmeters, galvanometers, d-c amplifiers, and electrometers require the minimum of manual adjustment and are easy to read but the operator is required to make the reading at a particular time. The Wheatstone bridge (Fig. X1.4) and the potentiometer method (Fig. X1.2 (b)) require the undivided attention of the operator in keeping a balance, but allow the setting at a particular time to be read at leisure.

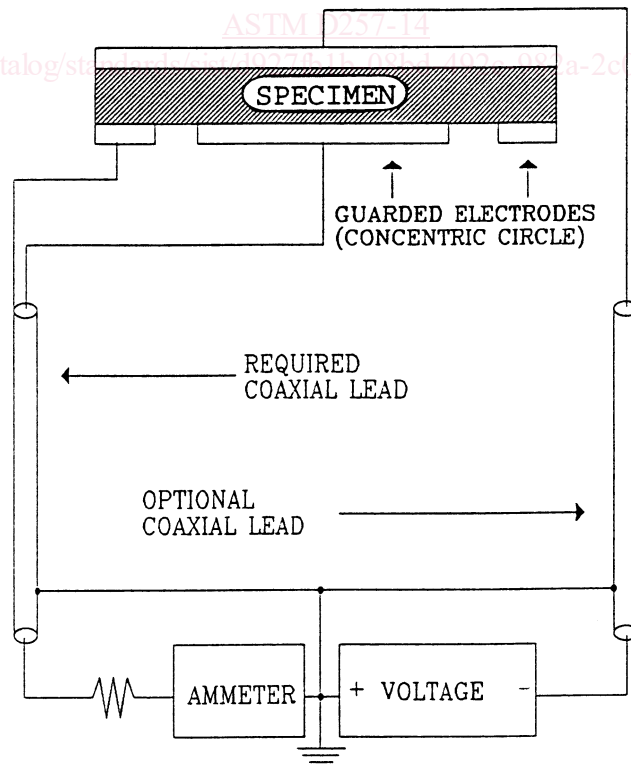

FIG. 9 Connections to Guarded Electrode for Volume and Surface Resistivity Measurements (Volume Resistance hook-up shown)