



Designation: ~~A889/A889M—03 (Reapproved 2008)~~ A889/A889M – 14

Standard Test Method for Alternating-Current Magnetic Properties of Materials at Low Magnetic Flux Density Using the Voltmeter-Ammeter- Wattmeter-Varmeter Method and 25-cm Epstein Frame¹

This standard is issued under the fixed designation A889/A889M; the number immediately following the designation indicates the year of original adoption or, in the case of revision, the year of last revision. A number in parentheses indicates the year of last reapproval. A superscript epsilon (ϵ) indicates an editorial change since the last revision or reapproval.

1. Scope

1.1 This test method covers tests for the magnetic properties of basic flat-rolled magnetic materials at power frequencies (25 to 400 Hz) using a 25-cm Epstein test frame and the 25-cm double-lap-jointed core.

1.2 The magnetic properties of materials are determined from measurements on Epstein core specimens with the core and test coils treated as though they constituted a series-parallel equivalent circuit (Fig. A1.1) for the fundamental frequency of excitation where the apparent parallel inductance, L_1 , and resistance, R_1 , are attributable to the test specimen.

1.3 This test method is suitable for the determination of core loss, rms volt-amperes, rms exciting current, reactive volt-amperes, and related properties of flat-rolled magnetic materials under ac magnetization.

1.4 The frequency range of this test method is normally that of the commercial power frequencies 50 to 60 Hz. It is also acceptable for measurements at frequencies from 25 to 400 Hz. This test method is customarily used on nonoriented electrical steels at inductions up to 10 kG [1.0 T] and for grain-oriented electrical steels at inductions up to 15 kG [1.5 T].

1.5 For reactive properties, both flux and current waveforms introduce limitations. Over its range of useful inductions, the varmeter is valid for the measurement of reactive volt-amperes (vars) and inductance permeability. For the measurement of these properties, it is suggested that test inductions be limited to values sufficiently low that the measured values of vars do not differ by more than 15 % (Note 1) from those calculated from the measured values of exciting volt-amperes and core loss.

NOTE 1—This limitation is placed on this test method in consideration of the nonlinear nature of the magnetic circuit, which leads to a difference between vars based on fundamental frequency components of voltage and current and current after harmonic rejection and vars computed from rms current, voltage, and watt values when one or more of these quantities are nonsinusoidal.

1.6 This test method shall be used in conjunction with Practice [A34/A34M](#).

1.7 Explanation of terms, symbols, and definitions used may be found in the various sections of this test method. The official list of definitions and symbols may be found in Terminology [A340](#).

1.8 The values ~~stated in either SI units or inch-pound units and equations stated in customary (cgs-emu and inch-pound) or SI units~~ are to be regarded separately as standard. Within this standard, SI units are shown in brackets except for the sections concerning calculations where there are separate sections for the respective unit systems. The values stated in each system may not be exact equivalents; therefore, each system shall be used independently of the other. Combining values from the two systems may result in non-conformance with the standard. Within this standard, SI units are shown in brackets. nonconformance with this standard.

1.9 *This standard does not purport to address all of the safety concerns, if any, associated with its use. It is the responsibility of the user of this standard to establish appropriate safety and health practices and determine the applicability of regulatory limitations prior to its use.*

2. Referenced Documents

2.1 *ASTM Standards:*²

[A34/A34M Practice for Sampling and Procurement Testing of Magnetic Materials](#)

¹ This test method is under the jurisdiction of ASTM Committee [A06](#) on Magnetic Properties and is the direct responsibility of Subcommittee [A06.01](#) on Test Methods. Current edition approved ~~May 1, 2008~~ May 1, 2014. Published ~~June 2008~~ May 2014. Originally approved in 1988. Last previous edition approved in ~~2003~~ 2008 as [A889/A889M-03-03 \(2008\)](#). DOI: ~~10.1520/A0889-A0889M-03R08~~ 10.1520/A0889_A0889M-14.

² For referenced ASTM standards, visit the ASTM website, www.astm.org, or contact ASTM Customer Service at service@astm.org. For Annual Book of ASTM Standards volume information, refer to the standard's Document Summary page on the ASTM website.

A340 Terminology of Symbols and Definitions Relating to Magnetic Testing
A343/A343M Test Method for Alternating-Current Magnetic Properties of Materials at Power Frequencies Using Wattmeter-Ammeter-Voltmeter Method and 25-cm Epstein Test Frame

3. Significance and Use

3.1 This test method may be used to determine the specific core loss, specific reactive power, specific exciting power, inductance permeability, and impedance permeability of flat-rolled magnetic materials over a wide range of inductions and at frequencies up to 400 Hz for symmetrically magnetized test samples.

3.2 These measurements are used by the producer and user of the flat-rolled material for quality control purposes. The fundamental assumption inherent in these measurements is that they can be correlated with the electromagnetic characteristics of a core fabricated from the flat-rolled material.

4. Test Specimen

4.1 Select and prepare the specimens for this test in accordance with Practice A34/A34M.

5. Basic Circuit

5.1 **Fig. 1** shows the essential apparatus and basic circuit connections for this test. Terminals 1 and 2 are connected to a source of adjustable ac voltage of sinusoidal waveform of sufficient power rating to energize the primary circuit without appreciable voltage drop in the source impedance. All primary circuit switches and all primary wiring should be capable of carrying much higher currents than are normally encountered to limit primary circuit resistance to values that will not cause appreciable distortion of the flux waveform in the specimen when relatively nonsinusoidal currents are drawn. The ac source may be an electronic amplifier which has a sine-wave oscillator connected to its input and may include the necessary circuitry to maintain a sinusoidal flux waveform by using negative feedback of the induced secondary voltage. In this case, higher primary resistance can be tolerated since this system will maintain sinusoidal flux at much higher primary resistance. Although the current drain in the secondary is quite small, especially when using modern high-input impedance instrumentation, the switches and wiring should be selected to minimize the lead resistance so that the voltage available at the terminals of the instruments is imperceptibly lower than the voltage at the secondary terminals of the Epstein test frame.

6. Apparatus

6.1 The apparatus shall consist of as many of the following component parts as are required to perform the desired measurement functions:

6.2 *Epstein Test Frame* used for this test shall be in conformity with Annex A1.1 of Test Method A343/A343M.

6.3 *Voltage and Current Signal Scaling Amplifiers*—These amplifiers are used to amplify or attenuate the voltage induced in the secondary winding of the test frame and the voltage appearing across the potential terminals of the current shunt, R_s , to ranges that are suitable for electronic circuitry. The input circuitry of the voltage scaling amplifier must have an input impedance sufficiently high that the connection of the circuitry to the secondary winding of the test fixture does not change the terminal voltage of the secondary by more than 0.05 %. The input circuitry of the current scaling amplifier must have an input impedance sufficiently high that the connection of the circuitry to the potential terminals of the current shunt does not change the terminal voltage by more than 0.05 %. These amplifiers should have a linear frequency response up to about 20 times the test frequency and a gain accuracy of 0.1 % or better since all instrumentation may be, and preferably will be, connected to the output of these amplifiers. Care should be exercised in the design of the amplifiers so that no phase shift is introduced into either the current or the voltage signal.

6.4 *Flux Voltmeter*—The flux voltmeter for this test shall be a true average-responsive voltmeter calibrated to read average volts

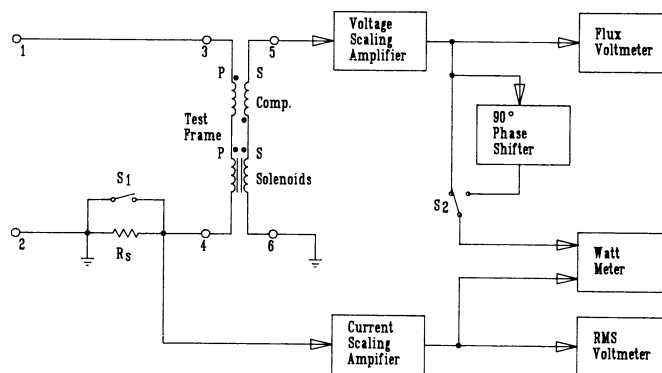

FIG. 1 Basic Circuit for Wattmeter-Varmeter Method



times $\sqrt{2} \pi/4$, so that its indications will be identical with those of a true rms voltmeter on a pure sinusoidal voltage. A high-input-resistance, multirange electronic meter with a full-scale accuracy rating of 0.25 % or better is the preferred instrument.

6.5 RMS Voltmeter—A true rms-indicating voltmeter is needed if measurements of exciting current are to be made by measuring the voltage drop across the potential terminals of the current shunt. A high-input-resistance, multirange electronic instrument with a full-scale accuracy of 0.25 % or better is required for this instrument. This voltmeter may also be used to measure the true rms voltage on the secondary of the Epstein test frame.

6.6 Wattmeter and Varmeter—A wattmeter is required for the measurement of core loss, and a varmeter is needed for the measurement of reactive power. Since both are needed to make all measurements, the preferred instrumentation is one high-accuracy watt converter and a 90° phase-shift circuit to be used with the watt converter to measure the reactive power by shifting the phase of the secondary voltage. Alternatively, a wattmeter and a varmeter may be used as required to make the desired measurements. The rated accuracy of the wattmeter at the test frequency and unity power factor should be less than 0.25 % of full scale. The power factor encountered by the wattmeter during a core loss test on a specimen is always less than unity and, at inductions well above the knee of the magnetization curve, approaches zero. The wattmeter must maintain adequate accuracy (1 % of reading) even at the most severe (lowest) power factor which will be presented to it. The accuracy requirements for the varmeter are the same as for the wattmeter.

6.6.1 Watt Converter and Phase Shifter—An electronic watt converter that has two high impedance inputs and an output that is proportional to the product of the signals that are applied to these inputs is the preferred instrument for the measurement of both power and reactive power. Such devices will probably require the use of scaling amplifiers for the voltage and current signals. This device, which is used for the measurement of power, is also used for the measurement of reactive power by shifting the phase of the voltage signal by 90°. This can be done since the secondary voltage is essentially a pure sinusoid at low-to-moderate inductions, especially if negative feedback of the secondary voltage is used in the test power supply circuitry. The phase shifter that is used for this purpose should be a modern operational amplifier device which will accurately shift the phase of the input signal by exactly 90° (tolerance of 0.1°) without affecting the amplitude of the signal.

6.6.2 Wattmeter—An electronic wattmeter with appropriate voltage and current ratings is the preferred instrument if the separate scaling amplifiers and phase-shift circuits are not used. The voltage input circuitry of the electronic digital wattmeter must have an input impedance sufficiently high that the connection of the circuitry to the secondary winding of the test fixture does not change the terminal voltage of the secondary by more than 0.05 %. The voltage circuit must also be capable of accepting the maximum peak voltage which is induced in the secondary winding during testing. The current input circuitry of the electronic digital wattmeter must have an input impedance of no more than 1 Ω , and preferably no more than 0.1 Ω . The current input circuitry must also be capable of handling the maximum rms current and the maximum peak current drawn by the primary winding of the test fixture when core loss tests are being performed.

6.6.3 Varmeter—An electronic instrument with appropriate voltage and current ratings is the preferred instrument if the separate scaling amplifiers and phase-shift circuits are not used. The accuracy and impedance characteristics for the varmeter should be the same as for the wattmeter described in 6.6.2.

6.7 Current Shunt—This should be a noninductive resistor with an accuracy rating of 0.1 % or better. This resistor must be capable of handling the full exciting current of the test winding at the maximum test induction without destructive heating or more than specified loss of accuracy as a result of self heating. To avoid intolerable levels of distortion, the value of the resistor should be reasonably low. However, a large value of resistance is desirable to maximize the signal and reduce the effects of noise. Fixed resistors of 100, 10, and 1 Ω are useful values. The selection of shunt should be guided primarily by the primary current and should be the lowest value which retains an adequate signal-to-noise ratio.

6.8 Power Supply—A source of sinusoidal test power of low-internal impedance and excellent voltage and frequency stability is required for this test. Voltage stability within 0.1 % and frequency accuracy within 0.1 % should be maintained. Electronic power sources using negative feedback from the secondary winding of the test fixture to reduce flux waveform distortion have been found to perform quite satisfactorily in this test method.

7. Procedure

7.1 The first steps of procedure for this test method concern the preparations for testing Epstein specimens which are the same for this method as given in 6.1, 6.2, and 6.3 of Test Method A343/A343M.

7.2 Demagnetization—Connect the required apparatus as in Fig. 1 with the air-flux compensator in the test frame and Terminals 1 and 2 connected to a suitable power source. With Switch S_1 closed in the position to short R_S , increase the voltage supplied to the test frame from zero to a value in which the flux-voltmeter indicates an induction above the knee of the magnetization curve (where the exciting current increases sharply for a small increase in induction). At this point, decrease the voltage slowly and progressively during an elapsed time of 5 to 10 s so that the induction will be reduced smoothly to a point below the lowest induction at which tests are to be performed and near zero induction. This will demagnetize the specimen which is quite important, since most highly permeable materials become polarized by handling in the earth's magnetic field during loading of the specimens