



Designation: **F588—07 F588 – 14**

# Standard Test Methods for Measuring the Forced Entry Resistance of Window Assemblies, Excluding Glazing Impact<sup>1</sup>

This standard is issued under the fixed designation F588; the number immediately following the designation indicates the year of original adoption or, in the case of revision, the year of last revision. A number in parentheses indicates the year of last reapproval. A superscript epsilon ( $\epsilon$ ) indicates an editorial change since the last revision or reapproval.

## 1. Scope

1.1 These test methods cover the ability of window assemblies of various types to restrain, delay, or frustrate forced entry.

1.2 For purposes of these test methods, window assemblies are defined as described in 1.2.1 – 1.2.5 and as shown in Fig. 1. Window assemblies with a combination of operable sash and fixed panes (lites) shall be classified and tested separately for each type.

1.2.1 *Type A*—A window assembly which incorporates one or more sash that open by *sliding*, either vertically or horizontally within the plane of the wall.

1.2.2 *Type B*—A window assembly which incorporates one or more sash that are *hinged* at or near two corners of the sash and that open toward the exterior (outswinging) or toward the interior (inswinging).

1.2.3 *Type C*—A window assembly which incorporates one or more sash that are *pivoted* so that part of the sash opens toward the interior and part of it opens toward the exterior.

1.2.4 *Type D*—A window assembly which incorporates one or more *fixed* panes (lites) or stationary sash that are designed not to open.

1.2.5 *Type E*—A window assembly which incorporates a series of overlapping horizontal louvers that are pivoted simultaneously by a common actuator so that the bottom edge of each louver swings outward and the top edge swings inward during operation.

NOTE 1—See Fig. 1 for graphic depiction of window assembly types.

1.3 The values stated in ~~inch-pound~~ units are to be regarded as the standard. The values given in parentheses are for information only—mathematical conversions to SI units that are provided for information only and are not considered standard.

1.4 *This standard does not purport to address all of the safety concerns, if any, associated with its use. It is the responsibility of the user of this standard to establish appropriate safety and health practices and determine the applicability of regulatory requirements prior to use.*

## 2. Referenced Documents

2.1 *ASTM Standards:*<sup>2</sup>

E631 Terminology of Building Constructions

F1233 Test Method for Security Glazing Materials And Systems

2.2 *AAMA Standard:*<sup>3</sup>

AAMA 1302.5-76 Voluntary Specifications for Forced Entry Resistant Aluminum Prime Windows

2.3 *CAWM Standards:*<sup>3</sup>

CAWM 301-90 Forced Entry Resistance Tests for Windows

CMBSO 1-79 California Model Building Security Ordinance

<sup>1</sup> These test methods are under the jurisdiction of ASTM Committee E06 on Performance of Buildings and are the direct responsibility of Subcommittee E06.51 on Performance of Windows, Doors, Skylights and Curtain Walls.

Current edition approved April 1, 2007; May 1, 2014. Published April 2007; June 2014. Originally approved in 1979. Last previous edition approved in 2004/2007 as F588—04.F588—07. DOI: 10.1520/F0588-07.10.1520/F0588-14.

<sup>2</sup> For referenced ASTM standards, visit the ASTM website, www.astm.org, or contact ASTM Customer Service at service@astm.org. For *Annual Book of ASTM Standards* volume information, refer to the standard's Document Summary page on the ASTM website.

<sup>3</sup> Available from the American Architectural Manufacturers Association (AAMA), 1827 Walden Office Square, Suite 550, Schaumburg, IL, 60173. Schaumburg, IL 60173-4268, <http://www.aamanet.org>.

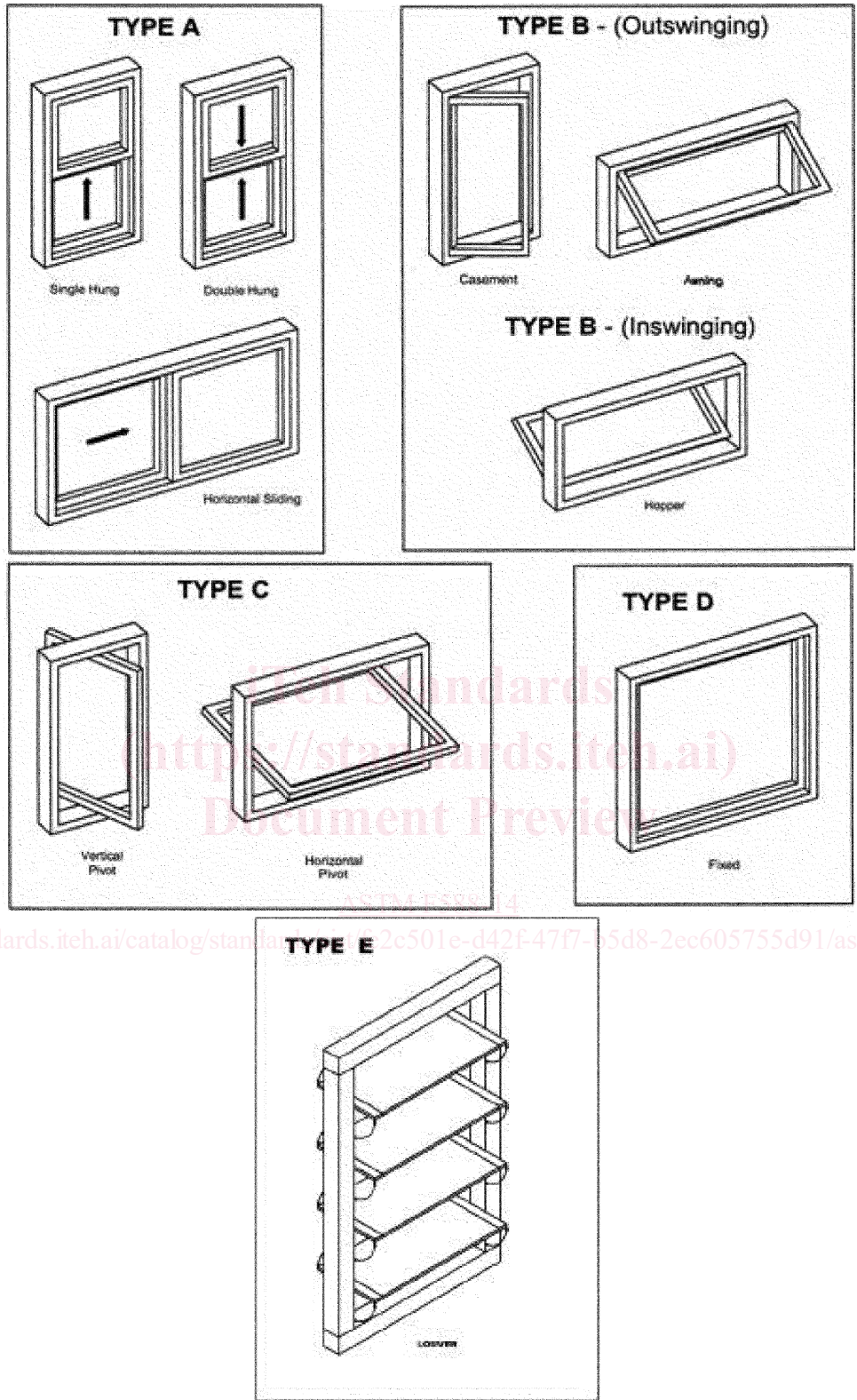

FIG. 1 Typical Window Types (viewed from the exterior)

### 3. Terminology

3.1 *Definitions*—Definitions for standard terminology can be found in Terminology E631.

3.2 *Definitions of Terms Specific to This Standard:*

3.2.1 *locking device(s) (lock), n*—one or more components of a window assembly intended to resist the opening of movable sash or louvers from the exterior.

3.2.2 *louver, n*—a glazing component of a louver window.

3.2.3 *louver holder, n*—a component of a louver window that holds the louvers at each end and transfers the pivoting and locking forces from the actuating mechanism/s to the louvers.

3.2.4 *sash operator, n*—a component of the window assembly that is used to move, pivot, or adjust the position of a movable sash within the window frame. (The sash operator in some window assemblies is also a locking device.)

### 4. Summary of Test Method

4.1 The procedure consists of mounting a specimen into a test assembly fixture which in turn is mounted to a wall support fixture, and, after removing all exterior fasteners and loose component items, specified loads and forces are applied to the window test specimen in a prescribed sequence. Following removal of all loads, a determination is made whether or not entry can be gained through the window test specimen from the exterior.

### 5. Significance and Use

5.1 These test methods are intended to establish a measure of resistance for window assemblies subjected to attacks (other than impacting glazing materials) by unskilled or opportunistic burglars. Resistance to higher levels of force generated by skilled burglary attack requires methods such as alarms, communication, or apprehension systems, or special security glazing materials more sophisticated than those evaluated by these test methods. Technicians performing the test should understand the intent of this test method and should be trained on the execution and pass/fail criteria.

5.2 Entry through a window assembly can be accomplished by impacting the glazing materials. This method does not evaluate glazing materials for breakage. Other standards must be used to evaluate forced entry by impacting the glazing.

5.3 Acceptance criteria for performance levels are a matter for authorities having specific jurisdiction to establish. Suggested guidelines are found in Annex A1.

### 6. Test Criteria

6.1 *Window Test Specimen*—The same window assembly shall be used for all testing and shall contain sash or louvers having the greatest height and width for which approval is sought. Each unique sash/frame or louver/frame arrangement shall be tested.

6.1.1 The construction of the window test specimen, including all hardware, components, and arrangement of sash or louvers shall be representative of that for which acceptance is desired.

6.1.2 The window test specimen shall consist of the entire assembled unit, including frame, glazing, and anchorage as supplied by the manufacturer for installation in the building.

6.1.3 Unless otherwise specified, the window test specimen shall contain annealed glass for testing and shall be single glazed if designed for either single or double glazing, or double glazed if designed exclusively for multiple glazing. Products tested with glazing materials other than annealed glass shall be used to qualify only the specific glazing material tested.

6.1.4 Windows tested with more than one locking device shall not qualify windows with fewer locking devices, regardless of size.

6.2 *Performance Criteria*—The performance level is attained if all locking devices remain engaged and entry cannot be gained during the test or upon removal of loads. If any component during testing, allowing entry, this shall be considered as failure to attain the performance level. Glazing which breaks, but does not allow entry, shall not be considered a failure to attain the performance level.

6.3 *Multiple Sash*—Window assemblies with a combination of operable sash and fixed panes (lites) shall be classified and tested separately for each type. If multiple sash within a window assembly are identical in construction and locking condition, only one sash need be tested.

6.4 *Multiple Louver*—Window assemblies with a combination of operable louvers, operable sash, or fixed panes (lites), or any combination thereof, shall be classified and tested separately for each type. If multiple louver windows within a window assembly are identical in construction and locking condition, only one louver window need be tested. If multiple louvers within a louver window are identical in construction and locking condition, only one louver need be tested.

6.5 *Test Sequence*—Perform the tests for each window test specimen in the sequence as outlined in Section 10. The sequence for testing multiple sash shall be at the discretion of the testing agency.

6.6 *Loading*—Apply test loads and forces at a rate not to exceed ~~45 N/s (10 lb/s)~~; 10 lb/s (45 N/s). Maintain performance loads for a period of  $60 \pm 5$  s.

6.7 *Load Removal*—At the conclusion of each test, remove all loads before starting the next test.

## 7. Apparatus

7.1 *Instrumentation*—Load and time measuring devices with an accuracy of  $\pm 2\%$  of the full scale shall be incorporated in the test setups. The scale ranges used shall assure that the performance levels are within an accuracy of  $\pm 5\%$ .

7.2 *Load Attachments*—Brackets, fasteners, or other devices used in performing these tests shall be designed and attached so as to minimize their influence on the test results.

7.3 *Test Frame*—The test fixture shall be designed and constructed to accept and rigidly secure the window specimen and to provide rigid points of anchor for all test loads described in Section 10. The load bearing members of the test fixture shall be constructed to limit deflection of such members to a maximum of ~~3 mm (1/8 in.)~~ 3 mm (0.118 in.) under full-prescribed load.

7.4 *Tools for Disassembly*—The following tools shall be used for disassembly of the test specimen:

7.4.1 A spatula, putty knife or other non-cutting tool with a thin blade,  $0.6 \pm 0.1$  mm ( $0.024 \pm 0.004$  in.) thick,  $20 \pm 2$  mm ( $0.78 \pm 0.08$  in.) wide, and  $90 \pm 10$  mm ( $3.5 \pm 0.4$  in.) ~~0.024  $\pm$  0.004 in. (0.6  $\pm$  0.1 mm) thick, 0.78  $\pm$  0.08 in. (20  $\pm$  2 mm) wide, and 3.5  $\pm$  0.4 in. (90  $\pm$  10 mm) long. (A Warner model #604 Putty Knife is known to meet these specifications.)<sup>4</sup>~~

7.4.2 Any non-powered, straight, or Phillips head screwdriver appropriate to the mechanical fastener with a maximum length of ~~150 mm (6 in.)~~ 6 in. (150 mm).

7.4.3 Standard slot-type pliers with a ~~150 to 175 mm (6 to 7 in.)~~ 6 to 7 in. (150 to 175 mm) overall length.

7.5 *Tools for Hardware Manipulation*—The following tools shall be used for manipulation of the locks of the test specimen:

7.5.1 A spatula, putty knife, or other non-cutting tool with a thin blade,  $0.6 \pm 0.1$  mm ( $0.24 \pm 0.004$  in.) thick,  $20 \pm 2$  mm ( $0.78 \pm 0.08$  in.) wide, and  $90 \pm 10$  mm ( $3.5 \pm 0.4$  in.) ~~0.24  $\pm$  0.004 in. (0.6  $\pm$  0.1 mm) thick, 0.78  $\pm$  0.08 in. (20  $\pm$  2 mm) wide, and 3.5  $\pm$  0.4 in. (90  $\pm$  10 mm) long. (A Warner model #604 is known to meet these specifications.)<sup>4</sup>~~

7.5.2 A piece of black annealed 16 gage wire at least long enough to reach from the point of insertion to the locking device(s). The properties of black annealed 16 gage wire are described in Machinery's Handbook, 22nd Edition<sup>5</sup>. 16 gauge wire refers to a wire diameter of ~~1.6 mm (0.0625 in.)~~ 0.0625 in (1.6 mm).<sup>6</sup>

## 8. Hazards

8.1 Glass breakage may occur during the application of loads or forces required by these test methods. Take adequate precautions to protect personnel from broken glass.

8.2 Locking devices, glass, and other window test specimen components may suddenly fail when loads and forces are applied during these test methods, causing sash to open rapidly. Take adequate precautions to protect personnel from rapidly moving weights and window test specimen components.

## 9. Preparation

9.1 Mount the window test specimen into a nominal ~~402 by 1004~~ or ~~40 by 150 mm (2 by 4 or 2 by 6 in.)~~ 2 by 6 in. (40 by 100 or 40 by 150 mm) lumber surround fixture, in accordance with the manufacturer's written installation instructions.

9.2 Install the window test specimen into the test fixture.

9.3 Close and lock the window test specimen. Submit each operable unit to five cycles of opening, closing, and locking prior to testing.

## 10. Procedure

10.1 The disassembly test, hardware manipulation test, sash manipulation test, and louver manipulation test referenced in the following parts of Section 10 are fully described in Annex A2.

10.2 *Type A Window Assembly:*

10.2.1 Perform the disassembly test defined in Annex A2, A2.1. Following the completion of the disassembly test perform tests A1 through A7 as defined in Annex A2 for the performance grade desired using the loads and times indicated in Table A1.1 in Annex A1. At the completion of tests A1 through A7 perform the hardware manipulation test and the sash manipulation test defined in Annex A2, A2.2, and A2.3.

10.3 *Type B Window Assembly:*

<sup>4</sup> The sole source of supply of the Warner model #604 known to the committee at this time is Warner Manufacturing Company, 13435 Industrial Park Blvd., Plymouth, MN 55441. If you are aware of alternative suppliers, please provide this information to ASTM International Headquarters. Your comments will receive careful consideration at a meeting of the responsible technical committee,<sup>1</sup> which you may attend.

<sup>5</sup> Available from Industrial Press, Inc. 200 Madison Ave. New York, NY 10016-4078.

<sup>6</sup> The sole source of supply of the apparatus known to the committee at this time is MacMAster Carr, P.O. Box 740100 Atlanta, GA 30374-0100. If you are aware of alternative suppliers, please provide this information to ASTM International Headquarters. Your comments will receive careful consideration at a meeting of the responsible technical committee,<sup>1</sup> which you may attend.

10.3.1 Perform the disassembly test defined in **Annex A2, A2.1**. Following the completion of the disassembly test perform tests B1 through B3 as defined in **Annex A2** for the performance grade desired using the loads and times indicated in **Table A1.1** in **Annex A1**. At the completion of tests B1 through B3 perform the hardware manipulation test and the sash manipulation test defined in **Annex A2, A2.2, and A2.3**.

10.4 *Type C Window Assembly:*

10.4.1 Perform the disassembly test defined in **Annex A2, A2.1**. Following the completion of the disassembly test perform tests C1 through C5 as defined in **Annex A2** for the performance grade desired using the loads and times indicated in **Table A1.1** in **Annex A1**. At the completion of tests C1 through C5 perform the hardware manipulation test and the sash manipulation test defined in **Annex A2, A2.2, and A2.3**.

10.5 *Type D Window Assembly:*

10.5.1 Perform the disassembly test defined in **Annex A2, A2.1**.

10.5.2 If a locking device is present anywhere on the window test specimen, perform the Hardware Manipulation Test and the Sash Manipulation Test defined in **Annex A2, sections A2.2 and A2.3** and attempt to remove the glazed panel within a time limit of (T1).

10.5.3 If a locking device is not present anywhere on the window test specimen, perform the sash manipulation test defined in **Annex A2, A2.3**, from the outside between the glazed panel and the remainder of the window test specimen, attempt to gain entry by attempting to open the glazed panel by hand and manipulating it with these tools, in any combination. Conduct this test continuously for a time limit of (T1).

10.6 *Type E Window Assembly:*

10.6.1 Perform the disassembly test defined in **Annex A2 and A2.1**. Following the completion of the disassembly test perform test E1 through E5 as defined in **Annex A2** for the performance grade desired using the loads and times indicated in **Table A1.1** in **Annex A1**. At the completion of the tests E1 through E5 perform the hardware manipulation test and the louver manipulation test defined in **Annex A2, A2.2, A2.4**.

## 11. Report

11.1 The report shall contain a description of the results of the test(s) performed in accordance with these test methods.

11.2 The report shall also include at least the following:

11.2.1 Identification of the window test specimen;

11.2.2 Type, size, location, and number of locking devices and other hardware;

11.2.3 Type, location, and number of installation fasteners;

11.2.4 Type and thickness of glazing material;

11.2.5 Bill of materials;

11.2.6 Assembly drawings;

11.2.7 Performance level, loads, and times (L1, L2, L3, T1) used;

11.2.8 A statement as to whether the window specimen complies or not, and the grade at which it complies;

11.2.9 A description of the method of installation or installation fastening; and

11.2.10 A description of the test equipment used.

## 12. Precision and Bias

12.1 These test methods do not generate numerical values. They establish a pass/fail condition which cannot generate numerical values for precision and bias.

## 13. Keywords

13.1 fenestration; forced entry resistance; laboratory method; windows

**ANNEXES**
**(Mandatory Information)**
**A1. SUGGESTED MEASURED PERFORMANCE**
**TABLE A1.1 Suggested Measured Performance<sup>A</sup>**

Load Identification	Grade 10	Grade 20	Grade 30	Grade 40
T1	5 min	5 min	10 min	10 min
L4	<del>667 N (150 lbf)</del>	<del>890 N (200 lbf)</del>	<del>1112 N (250 lbf)</del>	<del>1334 N (300 lbf)</del>
L1	150 lbf (667 N)	200 lbf (890 N)	250 lbf (1112 N)	300 lbf (1334 N)
L2	<del>333 N (75 lbf)</del>	<del>445 N (100 lbf)</del>	<del>556 N (125 lbf)</del>	<del>667 N (150 lbf)</del>
L2	75 lbf (333 N)	100 lbf (445 N)	125 lbf (556 N)	150 lbf (667 N)
L3	<del>111 N (25 lbf)</del>	<del>155 N (35 lbf)</del>	<del>222 N (50 lbf)</del>	<del>267 N (60 lbf)</del>
L3	25 lbf (111 N)	35 lbf (155 N)	50 lbf (222 N)	60 lbf (267 N)

<sup>A</sup> It is suggested that **Table A1.1** be used with the understanding that four levels of load identification are established with load identification 40 being the highest and 10 being the lowest. Use of load identifications should be selected in accordance with security objectives desired.

NOTE A1.1—Historically there have been two other standards for the evaluation of forced entry resistance of window assemblies. They are AAMA 1302.5-76 and CAWM 301-90. The significant differences are that the AAMA standard did not include the hardware manipulation test and did require that the separation of sash and frame during the application of

iTeh Standards  
 (https://standards.iteh.ai)  
 Document Preview

ASTM F588-14

<https://standards.iteh.ai/catalog/standards/sist/fe2c501e-d42f-47f7-b5d8-2ec605755d91/astm-f588-14>