



Designation: F842 – 14

# Standard Test Methods for Measuring the Forced Entry Resistance of Sliding Door Assemblies, Excluding Glazing Impact<sup>1</sup>

This standard is issued under the fixed designation F842; the number immediately following the designation indicates the year of original adoption or, in the case of revision, the year of last revision. A number in parentheses indicates the year of last reapproval. A superscript epsilon ( $\epsilon$ ) indicates an editorial change since the last revision or reapproval.

*This standard has been approved for use by agencies of the U.S. Department of Defense.*

## 1. Scope

1.1 These test methods determine the ability of sliding door assemblies to restrain, delay, or frustrate forced entry.

1.2 For purposes of these test methods, sliding door assemblies are defined as described in 1.2.1 – 1.2.4 and as shown in Fig. 1. Sliding door assemblies with a combination of operable panels and fixed panels (lites) shall be classified and tested separately for each type.

1.2.1 *Type A*—A sliding door assembly which incorporates one or more sliding panels that *lock to the jamb*.

1.2.2 *Type B*—A sliding door assembly which incorporates one or more sliding panels that *lock to an intermediate jamb*.

1.2.3 *Type C*—A sliding door assembly which incorporates one or more sliding panels that abut and *lock to other panels*.

1.2.4 *Type D*—A sliding door assembly which incorporates one or more fixed or stationary panels that are *designed not to open*.

NOTE 1—See Fig. 1 for graphic depiction of sliding door assembly types.

1.3 The values stated in inch-pound units are to be regarded as standard. The values given in parentheses are mathematical conversions to SI units that are provided for information only and are not considered standard.

1.4 *This standard does not purport to address all of the safety concerns, if any, associated with its use. It is the responsibility of the user of this standard to establish appropriate safety and health practices and determine the applicability of regulatory limitations prior to use.*

<sup>1</sup> These test methods are under the jurisdiction of ASTM Committee E06 on Performance of Buildings and are the direct responsibility of Subcommittee E06.51 on Performance of Windows, Doors, Skylights and Curtain Walls.

Current edition approved May 1, 2014. Published June 2014. Originally approved in 1983. Last previous edition approved in 2013 as F842 – 13. DOI: 10.1520/F0842-14.

## 2. Referenced Documents

2.1 *ASTM Standards*:<sup>2</sup>

E631 *Terminology of Building Constructions*

2.2 *AAMA Standard*:<sup>3</sup>

AAMA 1303.5 *Voluntary Specifications for Forced Entry Resistant Aluminum Sliding Glass Doors*

2.3 *CAWM Standards*:<sup>3</sup>

CAWM 300-96 *Forced Entry Resistance Tests for Sliding Glass Doors*

CMBSO 1-79 *California Model Building Security Ordinance*

## 3. Terminology

3.1 *Definitions*—Definitions for standard terminology can be found in Terminology E631.

3.2 *Definitions of Terms Specific to This Standard*:

3.2.1 *door frame assembly, n*—the combination of a head, sill, and jambs surrounding and supporting fixed and sliding panels.

3.2.2 *fixed jamb stile, n*—vertical members of fixed or stationary panels adjacent to any jamb.

3.2.3 *intermediate jamb, n*—vertical member of a frame other than the outermost vertical members.

3.2.4 *locking device(s) (lock), n*—one or more components of a sliding door assembly intended to resist opening of the sliding door panel from the exterior.

3.2.5 *sliding door assembly, n*—a combination of one or more sliding door panels with or without one or more fixed panels within a common frame.

<sup>2</sup> For referenced ASTM standards, visit the ASTM website, www.astm.org, or contact ASTM Customer Service at service@astm.org. For *Annual Book of ASTM Standards* volume information, refer to the standard's Document Summary page on the ASTM website.

<sup>3</sup> Available from the American Architectural Manufacturers Association (AAMA), 1827 Walden Office Square, Suite 550, Schaumburg, IL 60173-4268, http://www.aamanet.org.

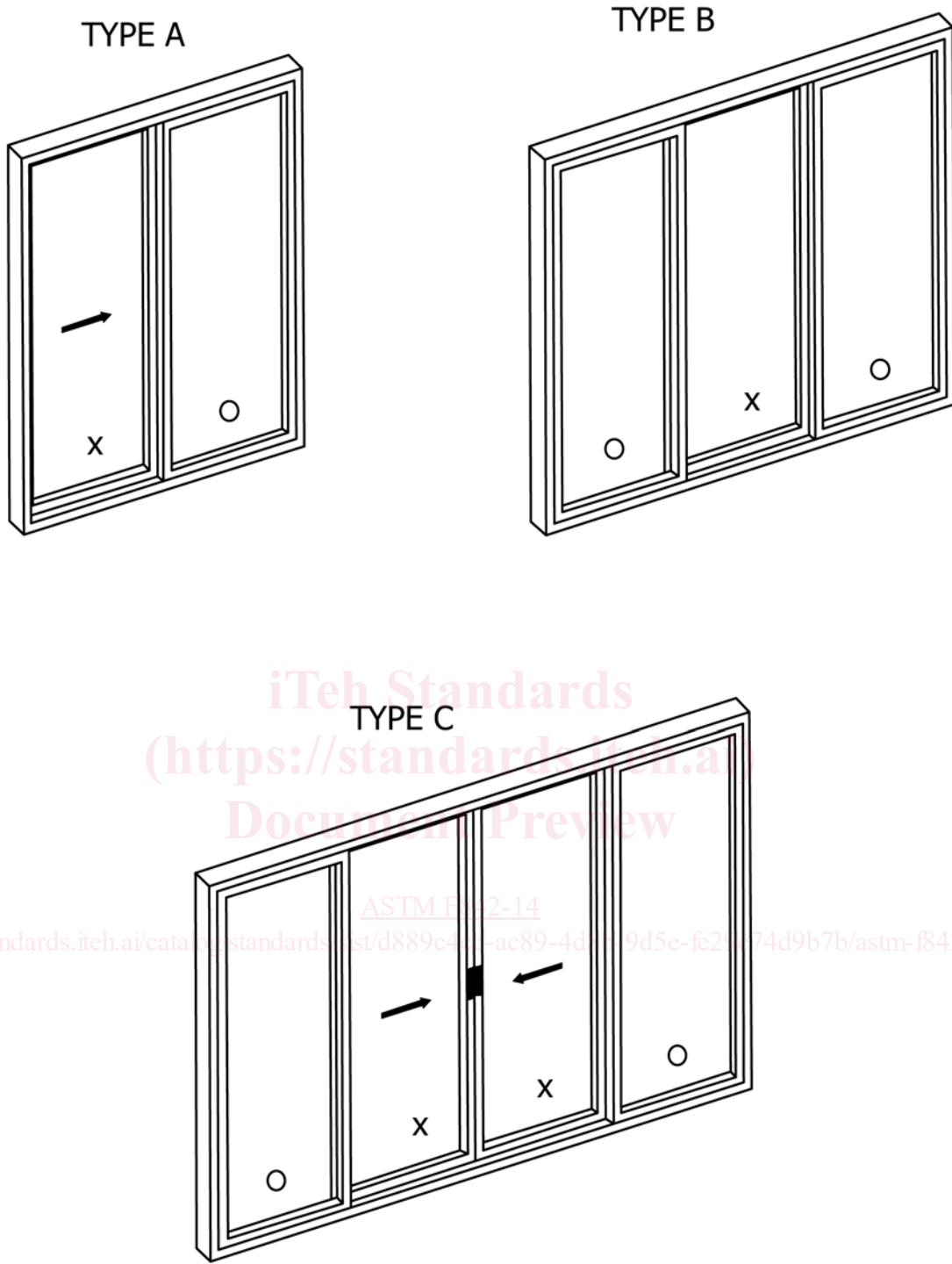

O - Non-operating Door Panel  
 X - Operating Door Panel  
**FIG. 1 Typical Horizontal Sliding Door Assembly Types (viewed from the exterior)**

**4. Summary of Test Method**

4.1 The procedure consists of mounting a sliding door specimen into a test assembly fixture which in turn is mounted

to a wall support fixture, and, after removing all exterior fasteners and loose component items, specified loads and forces are applied to the sliding door test specimen in a

prescribed sequence. Following removal of all loads, a determination is made whether or not entry can be gained through the sliding door test specimen from the exterior.

## 5. Significance and Use

5.1 These test methods are intended to establish a measure of resistance for sliding door assemblies subjected to attacks (other than impacting glazing materials) by unskilled or opportunistic burglars. Resistance to higher levels of force generated by skilled burglary attack requires methods, such as alarms, communication, or apprehension systems, or special security glazing materials more sophisticated than those evaluated by these test methods. Technicians performing the test should understand the intent of this test method and should be trained on the execution and pass/fail criteria.

5.2 Entry through a sliding door assembly can be accomplished by impacting or removing glazing materials. This method does not evaluate glazing materials for breakage or de-glazing. Other standards must be used to evaluate forced entry by impacting or removing glazing.

5.3 Acceptance criteria for performance levels are a matter for authorities having specific jurisdiction to establish. Suggested guidelines are found in [Annex A1](#).

## 6. Test Criteria

6.1 *Sliding Door Test Specimen*—The same sliding door assembly shall be used for all testing and shall contain panels having the greatest height and width for which approval is sought. Each unique panel/frame arrangement and locking arrangement shall be tested.

6.1.1 The construction of the sliding door test specimen, including all hardware, components, and arrangement of panels shall be representative of that for which acceptance is desired.

6.1.2 The sliding door test specimen shall consist of the entire assembled unit, including frame, glazing, and anchorage as supplied by the manufacturer for installation in the building.

6.1.3 Unless otherwise specified, the test specimen shall contain the weakest code compliant safety glazing for testing and shall be single glazed if designed for either single or double glazing, or double glazed if designed exclusively for multiple glazing. Products tested with glazing materials other than the weakest code compliant safety glazing shall qualify only the specific glazing material tested.

6.1.4 Sliding door assemblies tested with more than one locking device shall not qualify sliding door assemblies with fewer locking devices, regardless of size.

6.2 *Performance Criteria*—The performance level is attained if all locking devices remain engaged and entry cannot be gained during the test or upon removal of loads. If during testing, any component, including the glazing material, fails, allowing entry, this shall be considered a failure to attain the performance level. Glazing which breaks, but does not allow entry, shall not be considered a failure to attain the performance level.

6.3 *Multiple Panels*—Sliding door assemblies with a combination of operable panels and fixed panels (lites) shall be classified and tested separately for each panel type. If multiple

panels within a sliding door assembly are identical in construction and locking condition, only one panel need be tested.

6.4 *Test Sequence*—Perform the tests for each sliding door test specimen in the sequence as outlined in Section 10. The sequence for testing multiple panels shall be at the discretion of the testing agency.

6.5 *Loading*—Apply test loads and forces at a rate not to exceed 10 lb/s (45 N/s). Maintain performance loads for a period of  $60 \pm 5$  s.

6.6 *Load Removal*—At the conclusion of each test, remove all loads before starting the next test.

## 7. Apparatus

7.1 *Instrumentation*—Load and time measuring devices with an accuracy of  $\pm 2$  % of the full scale shall be incorporated in the test setups. The scale ranges used shall assure that the performance levels are within an accuracy of  $\pm 5$  %.

7.2 *Load Attachments*—Brackets, fasteners, or other devices used in performing these tests shall be designed and attached so as to minimize their influence on the test results.

7.3 *Test Frame*—The test fixture shall be designed and constructed to accept and rigidly secure the sliding door specimen and to provide rigid points of anchor for all test loads described in 10.3. The load bearing members of the test fixture shall be constructed to limit deflection of such members to a maximum of  $\frac{1}{8}$  in. (3 mm) under full prescribed load.

7.4 *Tools for Disassembly*—The following tools shall be used for disassembly of the test specimen:

7.4.1 A spatula, putty knife, or other non-cutting tool with a thin blade,  $0.024 \pm 0.004$  in. ( $0.6 \pm 1$  mm) thick,  $0.78 \pm 0.08$  in. ( $20 \pm 2$  mm) wide, and  $3.5 \pm 0.4$  in. ( $90 \pm 10$  mm) long. (A Warner model #604 Putty Knife is known to meet these specifications.)<sup>4</sup>

7.4.2 Any non-powered, straight, or Phillips head screwdriver appropriate to the mechanical fastener with a maximum length of 6 in. (150 mm).

7.4.3 Standard slot-type pliers with a 6 to 7 in. (150 to 175 mm) overall length.

7.5 *Tools for Hardware Manipulation*—The following tools shall be used for manipulation of the locks of the test specimen:

7.5.1 A spatula, putty knife, or other non-cutting tool with a thin blade,  $0.024 \pm 0.004$  in. ( $0.6 \pm 0.1$  mm) thick,  $0.78 \pm 0.08$  in. ( $20 \pm 2$  mm) wide, and  $3.5 \pm 0.4$  in. ( $90 \pm 10$  mm) long.<sup>4</sup>

7.5.2 A piece of black annealed 16 gage wire at least long enough to reach from the point of insertion to the locking device(s).<sup>5</sup>

<sup>4</sup> The sole source of supply of the Warner model #604 known to the committee at this time is Warner Manufacturing Company, 13435 Industrial Park Blvd., Plymouth, MN 55441. If you are aware of alternative suppliers, please provide this information to ASTM International Headquarters. Your comments will receive careful consideration at a meeting of the responsible technical committee,<sup>1</sup> which you may attend.

<sup>5</sup> The properties of black annealed 16 gage wire are described in *Machinery's Handbook*, 22nd Edition, Available from Industrial Press, Inc., 200 Madison Ave., New York, NY 10016-4078.

## 8. Hazards

8.1 Glass breakage may occur during the application of loads or forces required by these test methods. Take adequate precautions to protect personnel from broken glass.

8.2 Locking devices, glass, and other sliding door test specimen components may suddenly fail when loads and forces are applied during these test methods, causing panels to open rapidly. Take adequate precautions to protect personnel from rapidly moving weights and sliding door test specimen components.

## 9. Preparation

9.1 Mount the sliding door test specimen into a 2 by 4 or 2 by 6 in. (40 by 100 or 40 by 150 mm) lumber surround fixture, in accordance with the manufacturer's written installation instructions. Additional attachment means are permitted between the lock jamb and the test frame provided such means do not increase the strength of the connection between locking devices and the sliding door members beyond the door manufacturer's installation specifications.

9.2 Install the sliding door assembly specimen into the test fixture.

9.3 Close and lock the sliding door test specimen. Submit each operable unit to five cycles of opening, closing, and locking prior to testing.

## 10. Procedure

10.1 The disassembly test, hardware manipulation test, and panel manipulation test referenced in the following parts of Section 10 are fully described in Annex A2.

10.1.1 Without in any other manner intentionally damaging the sliding door test specimen, remove from the sliding door test specimens all screws, glazing beads, and any other members or other mechanical fasteners that can be removed readily from the exterior within a time limit of 5 min using the tools stipulated in 7.4.

### 10.2 Type A Sliding Door Assembly:

10.2.1 Perform the disassembly test defined in Annex A2, A2.1. Following the completion of the disassembly test perform tests A1 through A7 as defined in Annex A2 for the performance grade desired using the loads and times indicated in Table A1.1 in Annex A1. At the completion of tests A1 through A7 perform the hardware manipulation test and the panel manipulation test defined in Annex A2, A2.2, and A2.3.

### 10.3 Type B Sliding Door Assembly:

10.3.1 Perform the disassembly test defined in Annex A2, A2.1. Following the completion of the disassembly test per-

form tests B1 through B7 as defined in Annex A2 for the performance grade desired using the loads and times indicated in Table A1.1 in Annex A1. At the completion of tests B1 through B7 perform the hardware manipulation test and the panel manipulation test defined in Annex A2, A2.2, and A2.3.

### 10.4 Type C Sliding Door Assembly:

10.4.1 Perform the disassembly test defined in Annex A2, A2.1. Following the completion of the disassembly test perform tests C1 through C7 as defined in Annex A2 for the performance grade desired using the loads and times indicated in Table A1.1 in Annex A1. At the completion of tests C1 through C7 perform the hardware manipulation test and the panel manipulation test defined in Annex A2, A2.2, and A2.3.

### 10.5 Type D Sliding Door Assembly:

10.5.1 Perform the disassembly test defined in Annex A2, A2.1. Following the completion of the disassembly test perform tests D1 through D3 as defined in Annex A2 for the performance grade desired using the loads and times indicated in Table A1.1 in Annex A1. At the completion of tests C1 through C7 perform the hardware manipulation test and the panel manipulation test defined in Annex A2, A2.2, and A2.3.

## 11. Report

11.1 The report shall contain a description of the results of the test(s) performed in accordance with these test methods.

11.2 The report shall include at least the following:

11.2.1 Identification of the sliding door test specimen;

11.2.2 Type, size, location, and number of locking devices and other hardware;

11.2.3 Type, location, and number of installation fasteners;

11.2.4 Type and thickness of glazing material;

11.2.5 Bill of materials;

11.2.6 Assembly drawings;

11.2.7 Performance level, loads, and times (L1, L2, L3, L4, T1) used;

11.2.8 A statement as to whether the sliding door specimen complies or not and the grade at which it complies;

11.2.9 A description of the method of installation or installation fastening; and

11.2.10 A description of the test equipment used.

## 12. Precision and Bias

12.1 These test methods do not generate numerical values. They establish a pass/fail condition which cannot generate numerical values for precision and bias.

## 13. Keywords

13.1 doors; fenestration; forced entry resistance; laboratory method; sliding glass doors

**ANNEXES**
**(Mandatory Information)**
**A1. SUGGESTED MEASURED PERFORMANCE**
**TABLE A1.1 Suggested Measured Performance<sup>A</sup>**

Load Identification	Grade 10	Grade 20	Grade 25	Grade 30	Grade 40
T1	5 min	5 min	5 min	10 min	10 min
L1	300 lbf (1334 N)	500 lbf (2224 N)	800 lbf (3559 N)	800 lbf (3559 N)	1100 lbf (4893 N)
L2	175 lbf (778 N)	200 lbf (890 N)	200 lbf (890 N)	400 lbf (1779 N)	550 lbf (2447 N)
L3	30 lbf (133 N)	50 lbf (222 N)	50 lbf (222 N)	100 lbf (445 N)	150 lbf (667 N)
L4	50 lbf (222 N) plus weight of panel	50 lbf (222 N) plus weight of panel	50 lbf (222 N) plus weight of panel	50 lbf (222 N) plus weight of panel	50 lbf (222 N) plus weight of panel

<sup>A</sup> It is suggested that [Table A1.1](#) be used with the understanding that five levels of load identification are established with load identification 40 being the highest and 10 being the lowest. Use of load identifications should be selected in accordance with security objective desired. Grade 25 parallels the requirements of CMBSO 1-79 and CAWM 300-96.

**A2. TESTS**
**A2.1 Disassembly Test**

A2.1.1 Remove from the door test specimen all screws, glazing beads, and any other members or other mechanical fasteners that can be removed readily from the exterior within a time limit of 5 min using the tools stipulated in [7.4](#). Removal of the indicated parts shall be done carefully so as not to cause collateral damage to the specimen.

**A2.2 Hardware Manipulation Test**

A2.2.1 Examine the door test specimen and determine a method of inserting the tools in [7.5](#) from the outside so as to contact the locking device(s). Using one technician only, attempt to gain entry by manipulating the locking device(s) with these tools in any combination without intentionally removing material from the panel or frame to facilitate access to the locking devices. Conduct this test continuously for a time limit of (T1). Manipulation of the locking devices shall be done in a manner that will not cause collateral damage to the specimen.

**A2.3 Panel Manipulation Test**

A2.3.1 While attempting to open the sliding door assembly, lift, push, pull or otherwise manipulate by hand from the exterior all panels to the full confines of the frame. This test shall be conducted continuously for a time limit of (T1).

**A2.4 Type A Sliding Door Assembly Tests**

A2.4.1 Perform the disassembly test defined in [Annex A2](#), section [A2.1](#).

A2.4.2 *Test A1*—With the sliding panels in the test position, a concentrated load (L1) shall be applied separately to each member incorporating a locking device, at a point on the panel

member within 3 in. (75 mm) of the locking device, in a direction parallel to the plane of the glass that would tend to open the panel. The load shall be distributed evenly between the interior and exterior sides of the locking device so as to minimize rotation. (Two equal concentrated loads which together equal L1.) (See [Fig. A2.1](#).)

A2.4.3 *Test A2*—With the sliding panels in the test position, a concentrated load (L1) shall be applied separately, from the exterior, to each member incorporating a locking device, at a point on the sash member within 3 in. (75 mm) of the locking device, in a direction parallel to the plane of the glass that would tend to open the panel, while, simultaneously, an additional concentrated load (L2) is applied to the panel member containing the locking device in the direction perpendicular to the plane of the glazing material toward the interior side of the sliding door test specimen. Where more than one primary lock is used, the loads shall be equally divided among the locks and shall be applied simultaneously. (Two equal concentrated loads which together equal L1.) (See [Fig. A2.2](#).)

A2.4.4 *Test A3*—With the sliding panels in the test position, a concentrated load (L1) shall be applied separately, from the exterior, to each member incorporating a locking device, at a point on the sash member within 3 in. (75 mm) of the locking device, in a direction parallel to the plane of the glass that would tend to open the panel, while, simultaneously, an additional concentrated load (L2) is applied to the panel member containing the locking device in the direction perpendicular to the plane of the glazing material toward the exterior side of the sliding door test specimen. Where more than one primary lock is used, the loads shall be equally divided among the locks and shall be applied simultaneously. (Two equal concentrated loads which together equal L1.) (See [Fig. A2.3](#).)

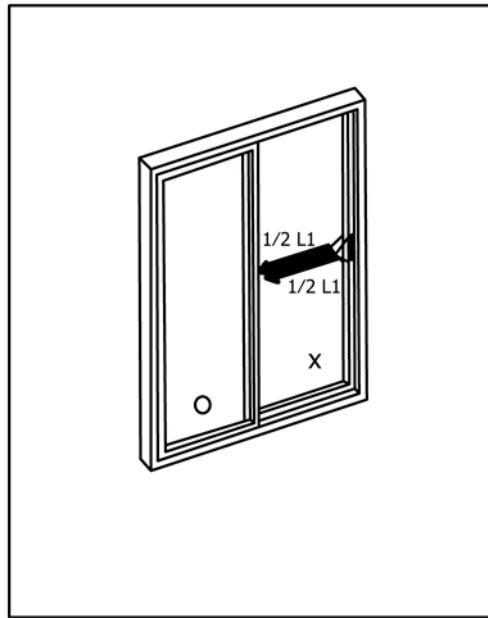

FIG. A2.1 Test A1

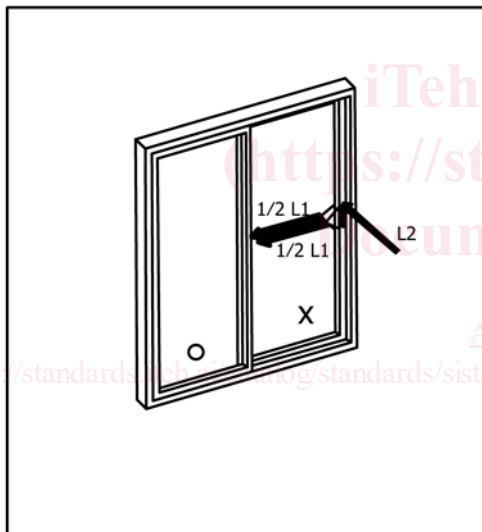

FIG. A2.2 Test A2

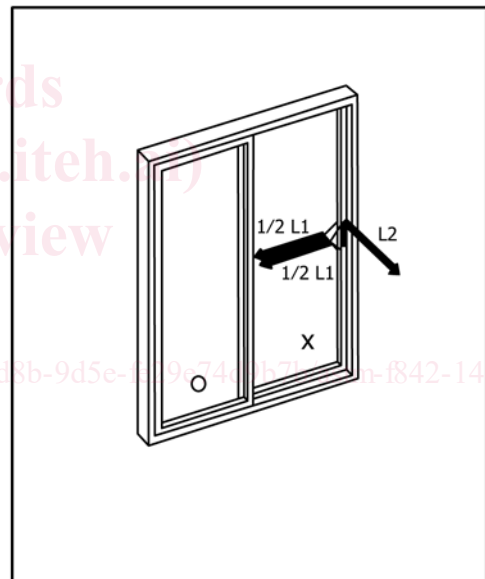

FIG. A2.3 Test A3

A2.4.5 *Test A4*—With the sliding panels in the test position, a concentrated load (L1) shall be applied separately, from the exterior, to each member incorporating a locking device, at a point on the sash member within 3 in. (75 mm) of the locking device, in a direction parallel to the plane of the glass that would tend to open the panel, while, simultaneously, an additional concentrated load (L2) is applied to the panel member containing the locking device in the direction perpendicular to the plane of the glazing material toward the interior side of the sliding door test specimen and, simultaneously, lifting the sliding door panel vertically to the uppermost limit within the confines of the sliding door frame assembly with a load (L4). Apply the lifting load at the mid-span of the bottom rail of the test panel. Where more than one primary lock is used, the loads shall be equally divided among the locks and

shall be applied simultaneously. (Two equal concentrated loads which together equal L1.) (See Fig. A2.4.)

A2.4.6 *Test A5*—With the sliding panels in the test position, a concentrated load (L1) shall be applied separately, from the exterior, to each member incorporating a locking device, at a point on the sash member within 3 in. (75 mm) of the locking device, in a direction parallel to the plane of the glass that would tend to open the panel, while, simultaneously, an additional concentrated load (L2) is applied to the panel member containing the locking device, in the direction perpendicular to the plane of the glazing material toward the exterior side of the sliding door test specimen and, simultaneously, lifting the sliding door panel vertically to the uppermost limit within the confines of the sliding door frame assembly with a