



Designation: D4884/D4884M – 14a

## Standard Test Method for Strength of Sewn or Bonded Seams of Geotextiles<sup>1</sup>

This standard is issued under the fixed designation D4884/D4884M; the number immediately following the designation indicates the year of original adoption or, in the case of revision, the year of last revision. A number in parentheses indicates the year of last reapproval. A superscript epsilon ( $\epsilon$ ) indicates an editorial change since the last revision or reapproval.

### 1. Scope

1.1 This test method covers the determination of the seam strength of geotextiles, using a wide specimen.

1.2 The long term performance of a seaming technique is not addressed by this test method. This test method will provide data to indicate the short term seam strength that can be achieved for each particular geotextile and seam assembly construction. To assess the long term performance of a seaming technique, it is possible to use Practice [D6389](#), using this test method to determine the anticipated strength reduction in the initial, short term wide-width tensile strength (Test Method [D4595](#)) results.

1.3 The values stated in either SI units or inch-pound units are to be regarded separately as standard. The values stated in each system may not be exact equivalents; therefore, each system shall be used independently of the other. Combining values from the two systems may result in non-conformance with the standard.

1.4 *This standard does not purport to address all of the safety concerns, if any, associated with its use. It is the responsibility of the user of this standard to establish appropriate safety and health practices and determine the applicability of regulatory limitations prior to use.*

### 2. Referenced Documents

#### 2.1 ASTM Standards:<sup>2</sup>

[D76/D76M Specification for Tensile Testing Machines for Textiles](#)

[D1776 Practice for Conditioning and Testing Textiles](#)

[D1777 Test Method for Thickness of Textile Materials](#)

[D4439 Terminology for Geosynthetics](#)

[D4595 Test Method for Tensile Properties of Geotextiles by the Wide-Width Strip Method](#)

<sup>1</sup> This test method is under the jurisdiction of ASTM Committee [D35](#) on Geosynthetics and is the direct responsibility of Subcommittee [D35.01](#) on Mechanical Properties.

Current edition approved May 1, 2014. Published June 2014. Originally approved in 1989. Last previous edition approved in 2014 as D4884/D4884M – 14. DOI: 10.1520/D4884\_D4884M-14A.

<sup>2</sup> For referenced ASTM standards, visit the ASTM website, [www.astm.org](http://www.astm.org), or contact ASTM Customer Service at [service@astm.org](mailto:service@astm.org). For *Annual Book of ASTM Standards* volume information, refer to the standard's Document Summary page on the ASTM website.

[D6389 Practice for Tests to Evaluate the Chemical Resistance of Geotextiles to Liquids](#)

[E178 Practice for Dealing With Outlying Observations](#)

[E691 Practice for Conducting an Interlaboratory Study to Determine the Precision of a Test Method](#)

2.2 *Federal Standard*.<sup>3</sup>

[Fed. Std. No. 751a Stitches, Seams, and Stitchings](#)

### 3. Terminology

#### 3.1 Definitions:

3.1.1 *adhered seam, n*—in geotextiles, a seam made by the application of an adhesive.

3.1.2 *cross-machine direction*—the direction in the plane of the geotextile perpendicular to the direction of manufacture.

3.1.3 *geotextile, n*—a permeable geosynthetic comprised solely of textiles.

3.1.4 *linear density, n*—mass per unit length; the quotient obtained by dividing the mass of a fiber or yarn by its length.

3.1.5 *machine direction*—the direction in the plane of the geotextile parallel to the direction of manufacture.

3.1.6 *seam allowance, n*—the width of geotextile used in making a seam assembly, for sewn seams bounded by the edge of the geotextile and the furthest stitch line, and for thermally bonded seams bounded by the edge of the geotextile and the furthest seam edge.

3.1.6.1 *Discussion*—In geotextiles, the distance from the selvage or turned edge of the geotextile to the edge of the seam.

3.1.7 *seam assembly, n*—the unit obtained by joining geotextile with a seam, including details such as geotextile direction(s), seam allowance, seam width, seam type, speed, and if sewn—sewing threads used and number of stitches per unit length, needle type and size, and if adhered – adhesive used, amount of adhesive in weight per unit area, overlap dimension and one or both sides with adhesive applied and so forth.

3.1.8 *seam design engineering, n*—the procedures used to select a specific thread, a specific stitch type, and a specific seam type to achieve the required seam strength of a sewn seam and the procedures used to select a specific seam width,

<sup>3</sup> Available from DLA Document Services, Building 4/D, 700 Robbins Ave., Philadelphia, PA 19111-5094, <http://quicksearch.dla.mil>.

specific seam bonding temperature, a specific seam speed and pressure to achieve the required seam strength of a thermally bonded seam and the type and amount of adhesive, overlap dimension and whether the adhesive was applied to one or both sides of the overlap to achieve the required seam strength of an adhered seam.

3.1.9 *seam interaction, n*—the result of combining specific textile, a specific stitch type, and a specific seam type for a sewn seam, the result of combining specific textile, a specific seam width, a specific seam speed, and applied pressure for a thermally bonded seam and the type and amount of adhesive, overlap dimension and whether the adhesive was applied to one or both sides of the overlap to achieve the required seam strength of an adhered seam.

3.1.10 *seam strength, n—for geotextiles*, the maximum resistance, measured in kilonewtons per metre, of the junction formed by stitching together two or more planar structures.

3.1.11 *seam type, n—in sewn geotextiles*, an alphanumeric designation relating to the essential characteristics of geotextile positioning and rows of stitching in a specific sewn geotextile seam (see Fed. Std. No. 751a).

3.1.11.1 *Discussion*—The first two letters of the designation show seam type; the third and subsequent letter specify a particular mating alignment; the number designation indicates the number of rows of stitches.

3.1.12 *seam weld, n*—the process by which a seam is formed through the thermal bonding of separate layers of geotextile.

3.1.13 *selvage, n*—the woven edge portion of a geotextile parallel to the machine direction.

3.1.13.1 *Discussion*—The edge of a nonwoven geotextile cannot be easily distinguished to determine either the machine or cross-machine direction.

3.1.14 *sewing thread, n*—a flexible, small diameter yarn or strand, usually treated with a surface coating, or lubricant, or both, intended to be used to stitch one or more pieces of material or an object to a material.

3.1.15 *sewn seam, n—in sewn geotextiles*, a series of stitches joining two or more separate plies of a material or materials of planar structure such as a textile geotextile.

3.1.16 *stitch, n*—the repeated unit formed by the sewing thread in the production of seams in a sewn geotextile (see Fed. Std. No. 751a).

3.1.17 *thermally bonded seam, n—in geotextiles*, a seam made by the application of thermal energy.

3.1.18 For definitions of other terms relating to geotextiles, refer to Terminology **D4439**.

## 4. Summary of Test Method

4.1 A seam, 200 mm [8 in.] wide is gripped across the entire width in the clamps of a tensile testing machine, operated at a prescribed rate of extension, applying a longitudinal (perpendicular) force to the specimen until the seam or geotextile ruptures.

## 5. Significance and Use

5.1 As explained in Test Method **D4595**, narrow geotextile specimens demonstrate the tendency to contract (neck down) in the gage area when under stress. The wider width specimen will minimize this phenomenon in seams during strength testing. The results achieved in this test method can more accurately correlate to the seam strength values anticipated in the field.

5.2 This test method can be used to measure the seam strength of geotextiles, and may also be used for acceptance testing of commercial shipments of geotextiles.

5.3 This test method can be used to help determine seam design engineering for the geotextiles being evaluated.

5.4 This test method is not intended to address long term performance of a seam nor any of its components such as the thread or the adhesive. However, it can be used as an index value to monitor the behavior of a seam exposed to any particular exposure, in example as part of an effort to assess its long term performance.

## 6. Apparatus

6.1 *Tensile Testing Machine*, must be of the constant-rate-of-extension (CRE) type, conforming to Specification **D76/D76M** and equipped with a recorder having an adequate pen response or interfaced computer to record the load elongation curve. The machine must be set to a rate of extension of  $10 \pm 3$  %/min.

6.2 *Clamps*—The clamps shall be wide enough to grip the entire width of the specimen and have the appropriate clamping power to hold the test specimen in place without crushing (damaging) the geotextile.

6.2.1 Caution must be taken to ensure that the type of clamp used is adequate for the seam strength being measured.

6.3 *Size of Jaw Faces*—Each clamp shall have a clamping face wider than the width of the specimen, typically 225 mm [8.86 in.] or larger, and a minimum of 50 mm [2 in.] in the direction of the applied force. The size of jaw faces does not apply if roller clamps are used.

## 7. Sampling for Acceptance Testing and Number of Specimens

7.1 *Division into Lots and Lot Sample*—Divide the material into lots and take a lot sample as described in an applicable material specification, or as agreed upon between the purchaser and the supplier. In the absence of an applicable material specification or prior agreement between the purchaser and the supplier, sampling and testing intervals should be agreed upon between the purchaser and the supplier.

7.1.1 When the installation project requires that seams are made in both the machine and cross-machine directions, the number of samples and the subsequent specimens will increase proportionately.

7.2 *Laboratory Samples*—At a laboratory sample, cut a minimum of two swatches of geotextile from each of the lot units selected for testing. The swatches must be long and large enough to permit seaming and selection of representative

sections of seams for specimen preparation, such as, a minimum of 2000 mm [79 in.] in length and a minimum of 300 mm [12 in.] in width. The lengthwise direction of these swatches must be cut from opposite ends and opposite sides of the lot sample rolls and should be parallel to the direction in which the seam will be made.

7.2.1 When seams are made in both the machine and cross-machine direction, it is suggested that some type of special color identification marking be used to distinguish one from the other.

7.2.2 These swatches are then joined using the best seam engineering techniques determined by the purchaser and the supplier to achieve seam interaction.

7.2.3 It will be necessary to cut a sufficient number of swatches for both wet and conditioned tests.

7.3 Test Specimens:

7.3.1 Number of Specimens—In the absence of an applicable specification or prior agreement between the purchaser and the supplier, prepare at least six test specimens from the laboratory samples.

7.3.2 Test Specimen Size—Prepare test specimens from the laboratory sample. Each specimen should be approximately 250 mm [10 in.] wide with a stitch line in the center for sewn seams or approximately 200 mm [ $\pm 8$  in.] wide with the seam weld in the center for thermally bonded or adhered seams running parallel to either the machine or cross-machine directions as shown in Fig. 1(a) for sewn seams, Fig. 1(b) for thermally bonded seams or Fig. 1(c) for adhered seams.

7.3.2.1 Cut this wider specimen for sewn seams as shown in Fig. 1(a) to achieve a final test specimen width of 200 mm [8 in.]. When removing the shaded area from a specimen as shown in Fig. 1(a), the angles between the 25-mm extensions which are parallel to the seam and that section of the specimen having a finished width of 200 mm is 90°.

7.3.2.2 For some seaming patterns, cutting the thread may lead to a loss of the integrity of the seam, and thus to an underestimation of the seam strength. For these patterns, some means shall be used to lock the thread in place, such as using glue, or mechanically locking the thread on both ends of the seam by un-sewing the seam over a maximum length of 25 mm, without damaging the sewing thread, in order to have at

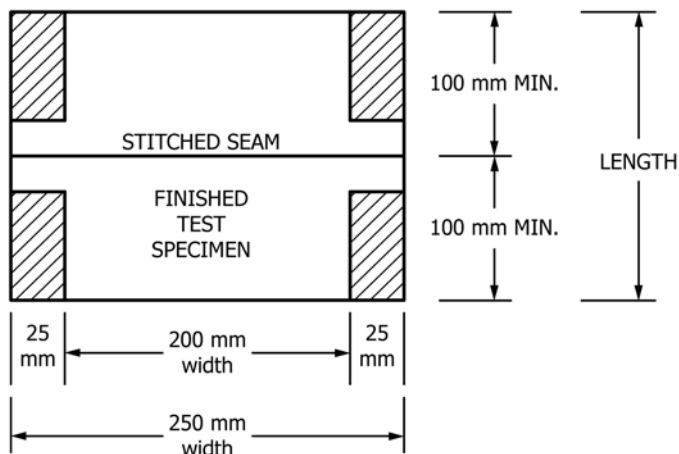

FIG. 1 (a) Test Specimen Preparation for Sewn Seam (Front View)

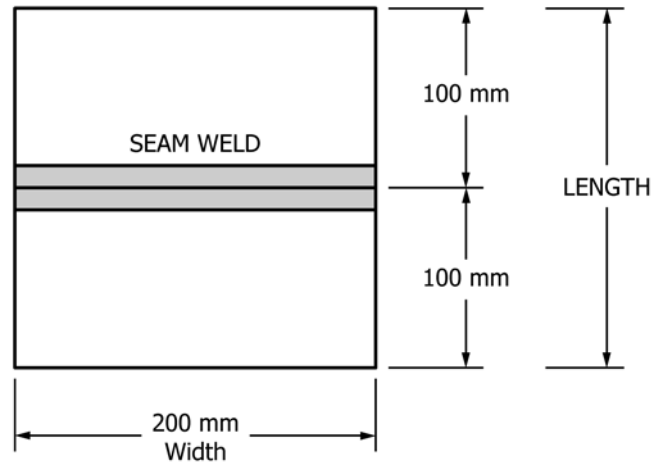
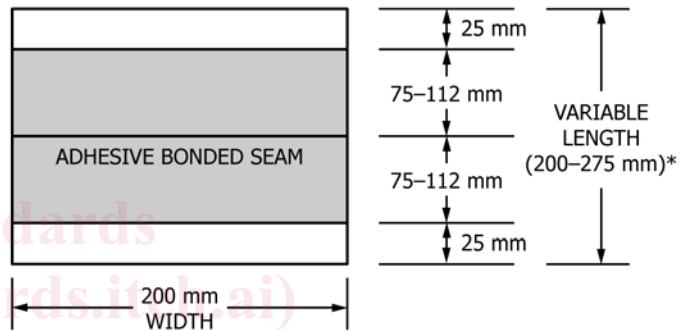

FIG. 1 (b) Test Specimen Preparation for Thermally Bonded Seam (Front View) (continued)



\*Where adhered seam overlap is 150 mm [6 in.] adhered seam specimen length is 200 mm; where adhered seam overlap is 225 mm [9 in.], adhered seam specimen length is 275 mm [11 in.].

FIG. 1 (c) Test Specimen Preparation for Adhesive Bonded Seam (Front View) (continued)

least 200 mm of intact seam centered in the axis of the specimen. Both upper and lower threads of the seam shall then be tied together to avoid any further modification to the structure of the stitch during the test.

8. Sampling of Field Seams and Factory Seams

8.1 The evaluation of field seams and factory seams will be made by taking samples at the stipulated intervals directed in Table 1 unless otherwise stated.

NOTE 1—To prevent the unnecessary waste of geotextile or impede the

TABLE 1 Seam Quality Control Sampling Requirements

Total Length of Field <sup>A</sup> Seams for Project, m [yd]	Sample Interval <sup>B</sup> Requirements, m [yd]
Up to 10 000 [Up to 11 000]	1000 [1100]
10 001 to 150 000 [11 000 to 165 000]	1500 [1666]
150 000 and up [165 000 and up]	2000 [2200]

<sup>A</sup> Total length of field seams for project is the sum of all machine direction and cross-machine direction seams required to effect installation of geotextile(s).

<sup>B</sup> Samples will be taken at stipulated intervals along the total length of the field seams. The number of such intervals will be rounded to the next higher whole number.